

A close-up, high-resolution photograph of a tiger's face, focusing on its eye and whiskers. The tiger's fur is a mix of orange, brown, and white, with dark stripes. The eye is a golden-brown color with a dark pupil. The whiskers are long and white, extending from the bottom right of the frame. The background is a soft, out-of-focus light color.

samtec

the CATALOG

50 YEARS OF **SUDDEN SERVICE**[®]

A DIFFERENT BREED OF CAT

INNOVATIVE TECHNOLOGIES • SUDDEN SERVICE®

Founded in 1976, Samtec is much more than just another connector company. We put people first, along with a commitment to **exceptional service**, **quality products** and **innovative technologies** that take the industry further faster. This is enabled by our unique, **fully integrated business model**, which allows for true **collaboration and innovation** without the limits of traditional business models.

We believe that taking care of our customers and our employees is paramount in how we approach our business, and this belief is deeply ingrained throughout Samtec worldwide.

INNOVATIVE TECHNOLOGIES

At Samtec, integration leads to innovation. We are leading the way in high-performance system design and support for complete system optimization from **SILICON-TO-SILICON™**. Samtec is positioned to produce solutions quickly, with higher densities, faster speeds and smaller footprints to meet the demands of next generation systems.

From standard cataloged products to unique high-performance design, Samtec's **SOLUTION BLOCKS** are designed to support any interconnectivity need, regardless of application, performance requirements or environment.

Silicon-to-Silicon™ Solutions



HIGH-SPEED
BOARD-TO-BOARD

HIGH-SPEED
CABLE

OPTICS

RF

Core Board-to-Board



RUGGED/POWER

FLEXIBLE
STACKING

SUDDEN SERVICE®

Samtec is the service leader in the industry, offering unmatched technical support, free product samples and access to online resources, and innovative online tools to help streamline the design process.



QUICK REFERENCE

Company, Product & Service Overview	2-7
Integration Leads to Innovation	8-9
Sudden Service®	10-11
Online Tools	12-13
Express Modifications & Engineered Customs	14
Flyover® Technology & Eye Speed® Cable	96-97
Testing (SET, E.L.P.™, DQT)	202-203
Power Services	204

HIGH-SPEED BOARD-TO-BOARD

High-Speed/High-Density Arrays

NovaRay® Extreme Density/Speed Arrays	16-17
AcceleRate® HP High-Performance Arrays	18-19
AcceleRate® HD Slim Body Arrays	20-21
AcceleRate® mP Signal/Power Arrays	22-23
SEARAY™ High-Density Arrays	24-27
SEARAY™ 0.80 mm Pitch Arrays	28-29
LP Array™ Low Profile Arrays	30-31
SUPERNOVA™ Low Profile Compression Interposers	32
SureWare™ Rugged Hardware	34-36

High-Speed Mezzanine

Q Strip® Ground Plane Strips	38-41
Q2™ & Q Rate® Ground Plane Strips	42-44
High-Speed Signal & Power Combinations	45
Edge Rate® Contact Strips	48-54

Ultra Micro Interconnects

Razor Beam™ Hermaphroditic Strips	56-58
Micro Blade & Beam Strips	59-60

High-Speed Edge Card Connectors

0.60, 0.80 & 1.00 mm Pitch Generate® Edge Cards	62-69
Micro & Mini Edge Cards	70-77
PCI Express® Edge Cards	78-80

High-Speed Backplane

NovaRay® Micro Rugged Backplane	82-85
ExaMAX® High-Speed Backplane	86-88
ExaMAX® Backplane Flyover® Cable Systems	89-90
XCede® HD High-Density Backplane	92-94

HIGH-SPEED CABLE

Flyover® Panel Assemblies

Flyover® SFP/QSFP/OSFP Cable Systems	98-103
NovaRay® I/O Extreme Performance System	104-107
ExaMAX® I/O Shielded Cable System	108-109

Flyover® Mid-Board Cable Assemblies

NovaRay® Extreme Speed/Density System	112-113
AcceleRate® HP Extreme Density System	114-115
AcceleRate® Slim Cable System	116-117
AcceleRate® Mini Small Form Factor System	118-119
Si-Fly® LP Low Profile Cable System	120-121
Si-Fly® HD Co-Packaged & Near Chip Systems	122-124
Generate® Edge Card Systems	125-126

High-Speed Cable Assemblies

Micro Coax & Twinax Cable	128-129
SEARAY™ High-Density System	130-131
PCI Express® 4.0 & 5.0 Systems	132-133
Additional High-Speed Cable Assemblies	134

Rugged Features & Contact Systems	343
Industry Standards	344-345
Evaluation & Development Kits	346-347
High-Speed Channel Performance Metric	348
General Specifications	349
Index by Brand	350
RF Product Index	351
Index by Series	352-353

OPTICS

Optical Systems

FireFly™ Mid-Board Optical Transceivers	136-142
Halo® Next Gen Mid-Board Optical Transceivers	144-145

RF

RF Systems

50 Ω Precision RF (18 GHz to 110 GHz)	150-180
Nitrowave™ Microwave Cable Assemblies	151-154
Magnum RF® Ganged Solutions	164-165
Bulls Eye® Test Point Systems	174-177
Rugged Blind Mate Modules to 110 GHz	178-179
Flexible Waveguide Technology (V-band)	180
50 Ω and 75 Ω Solutions (3 GHz to 12 GHz)	181-195

RUGGED/POWER

Ultra Rugged

Ultra Rugged Systems & Features	198-201
Ultra Rugged Testing (SET, E.L.P.™, DQT)	202-203

High Power

mPOWER® Ultra Micro Power Systems	206-211
PowerStrip™ Systems	212-221
Mini Mate® & Power Mate® Systems	222-224

Rugged I/O

URSA® I/O Rugged Cable Systems	226-231
AccliMate™ Sealed I/O Systems	232-234

Tiger Eye™ Board-to-Board

.050" Pitch Tiger Eye™ Systems	236-241
0.80 mm Pitch Tiger Eye™ Systems	242-243
2.00 mm Pitch Tiger Eye™ Systems	244-246

Wire to Board

1.00 mm Pitch Micro Mate™ Systems	248-253
Tiger Eye™ Systems	254-258
Power Mate® & Mini Mate® Systems	259-261
PowerStrip™ Systems	262-264

FLEXIBLE STACKING

Board Stacking

Flexible Stacking	266-269
One-Piece Interfaces	270-271
0.50 mm, 0.635 mm, 0.80 mm Pitch Blade & Beam	272-277
0.80 mm & 1.00 mm Pitch Pin & Socket	278-282
.050" Pitch Strips	283-294
2.00 mm Pitch Headers & Stackers	295-302
2.00 mm Pitch Sockets & PC/104-Plus™	303-308
.025" (0.64 mm) SQ Post Headers, Stackers	309-319
.025" (0.64 mm) SQ Post Sockets & PC/104™	320-327

IDC/Flat Cable Systems

.100" Pitch IDC Systems	330-333
Tiger Eye™ IDC Systems	334-341
FFC Jumpers & Interfaces	342

HIGH-SPEED BOARD-TO-BOARD

OPEN-PIN-FIELD ARRAYS | GROUND PLANE & EDGE RATE® STRIPS | EDGE CARDS | ULTRA-MICRO | BACKPLANE



QSERIES®

ExaMAX®

XCede HD

ACCELERATE®mP

EDGE RATE SYSTEM

ACCELERATE®HD

ACCELERATE®HP

NOVARAY®

SEARAY™

RAZOR™ BEAM SYSTEM

RUGGED/POWER

ULTRA RUGGED | BLADE POWER | RUGGED I/O | BOARD-TO-BOARD | WIRE TO BOARD

NOVARAY I/O

mPOWER®

EDGE RATE SYSTEM

URSA I/O
ULTRA RUGGED CABLE SYSTEM

TIGER EYE SYSTEM

miniMATE®

FLEXIBLE STACKING

LOW PROFILE | PASS-THROUGH | ONE-PIECE | SKYSCRAPERS | SHROUDED HEADERS | IDC SYSTEMS

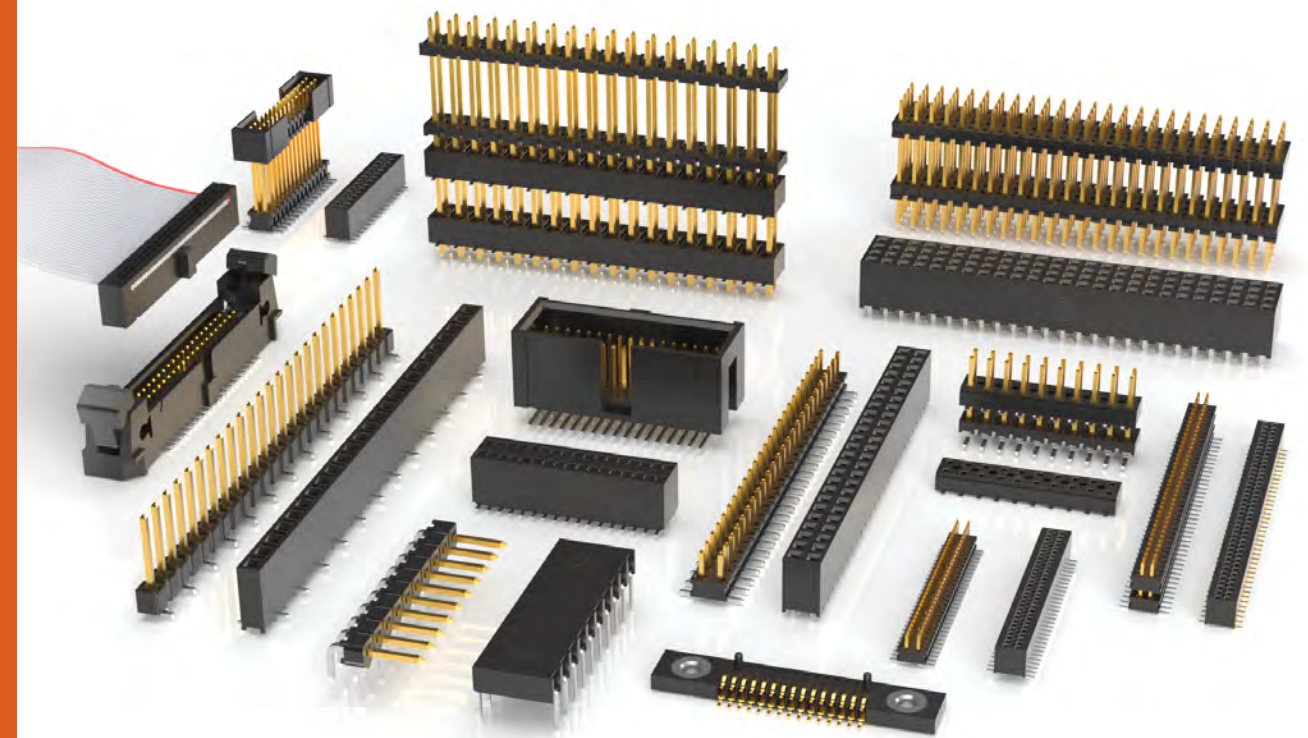

HIGH-SPEED CABLES

FLYOVER® & EYE SPEED® TECHNOLOGY | PANEL, MID-BOARD & BACKPLANE | MICRO COAX & TWINAX



OPTICS

MID-BOARD TRANSCEIVERS | EXTENDED TEMP/RAD HARD | PCI EXPRESS®-OVER-FIBER | NEXT GEN

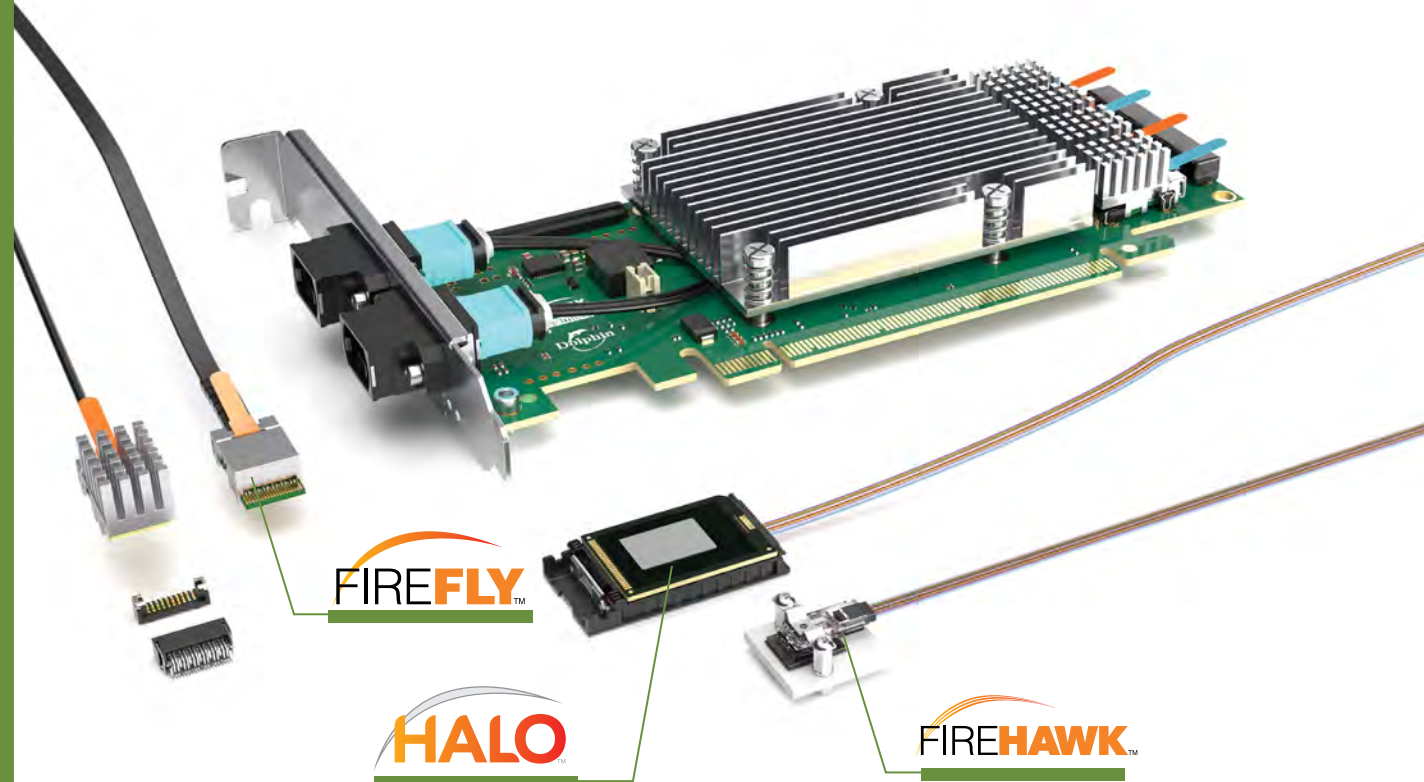

RF

CONNECTORS, CABLES & ORIGINAL SOLUTIONS | PRECISION RF | LOW FREQUENCY

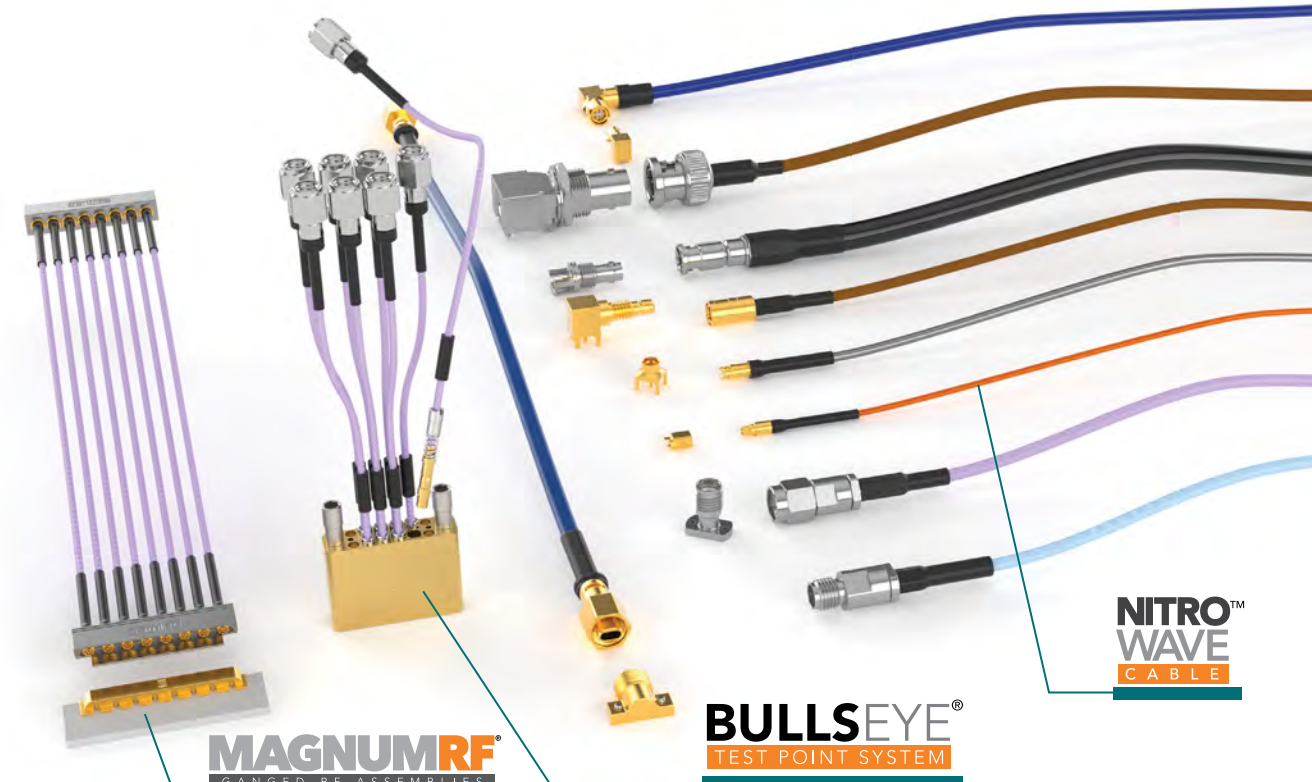

INTEGRATION LEADS TO INNOVATION

Samtec's integrated business model facilitates high-level design and development of advanced interconnect systems and **TECHNOLOGIES**. Along with industry-leading expertise, this allows us to offer effective strategies and support for **optimizing the entire signal channel of high-performance systems**.

Samtec is structured like no other company in the interconnect industry. We work in a fully integrated capacity that enables true collaboration and results in uniquely innovative **PRODUCTS** because **our technology teams are not limited by the boundaries of traditional business units**.



SILICON-TO-SILICON™ SOLUTIONS

As bandwidth, scale and power requirements continue to challenge conventional engineering methods, Samtec strives to help **optimize the landscape of your entire system** - and develop solutions, together.

Samtec's industry-leading **signal integrity expertise**, full system optimization strategies, and innovative products and technologies help address the challenges of **next gen data transmission to 224 Gbps and beyond**. Visit [samtec.com/S2S](https://www.samtec.com/S2S).

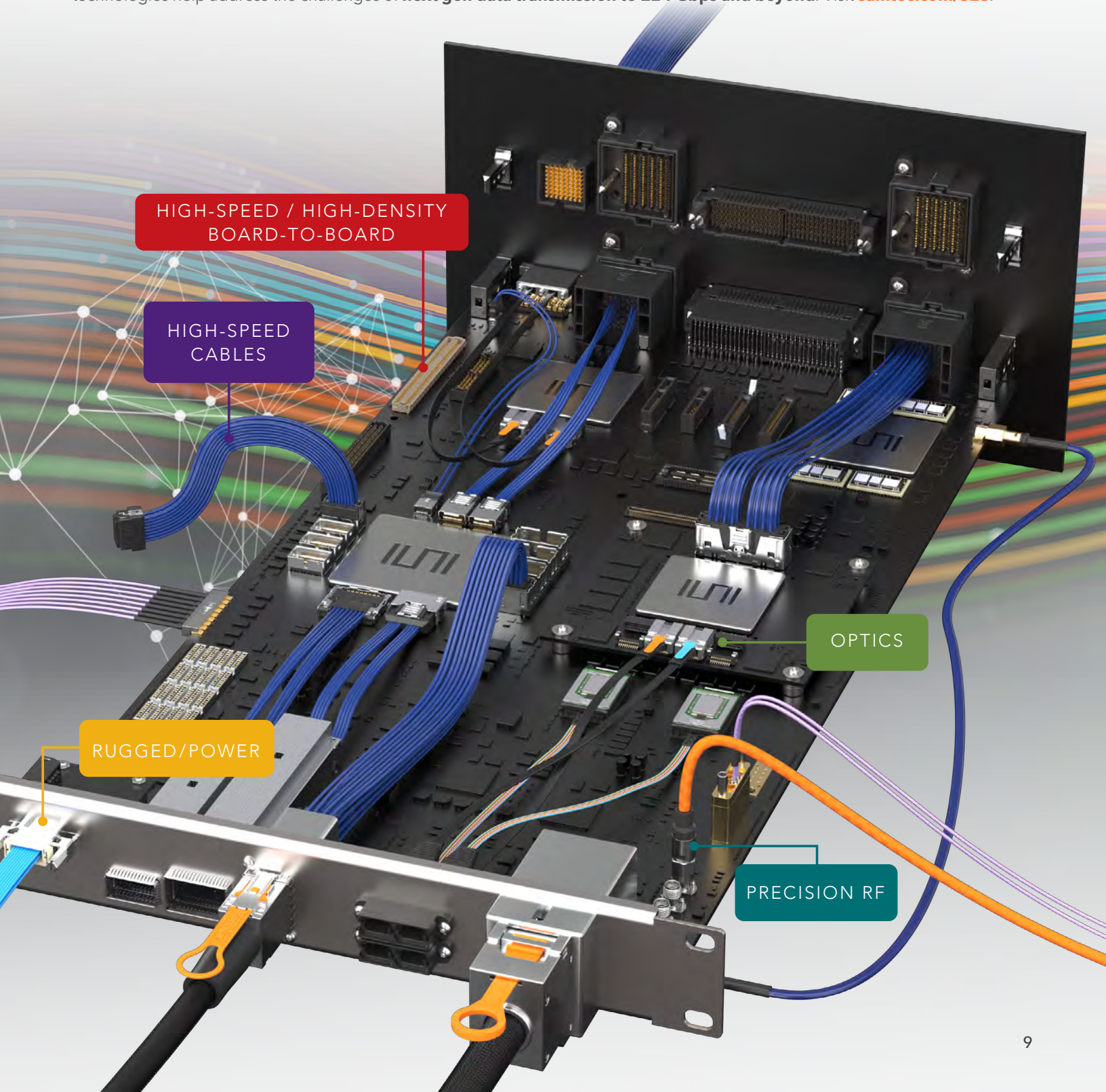

HIGH-SPEED / HIGH-DENSITY
BOARD-TO-BOARD

HIGH-SPEED
CABLES

RUGGED/POWER

OPTICS

PRECISION RF

SUDDEN SERVICE®

Samtec's Sudden Service® provides unmatched global service, free access to data and industry leading tools, along with engineering support, to help you design, develop, test and deliver the best solution for any complex application.

Our unique business model encourages flexibility and innovation, allowing us to quickly make adjustments, offer a variety of options and strategic solutions to best meet your specific needs – all while maintaining competitive pricing and the industry's best lead times.



GLOBAL OPERATIONS & SUPPORT NETWORK



WORLD DIRECT™

- Seamless global direct shipping
- Products ship factory direct to our customers and channel partners, without any unnecessary consolidation points
- Manufacturing flexibility without increased cost or lead times

FREIGHT COLLECT DIRECT

- Customers outside the US can receive shipments directly from a Samtec facility, reducing lead times & tariff exposure
- Customers inside the US that operate an FTZ, utilize a freight forwarder, or prefer to act as the IOR, can select a customized solution to meet unique business needs

REDUCING TARIFF EXPOSURE

- Dual-Operations model provides flexible options for manufacturing country of origin (COO)
- Less than 7% of Samtec's imports to the US are COO China
- Strategic US and Singapore distribution centers support our global customer base
- Flexible invoicing options for tariff-related charges
- For current tariff and part-specific tariff information, please visit samtec.com/tariff

PRICE COMPETITIVENESS

- Redundant manufacturing (Dual-Operations model) helps optimize labor and shipping costs, facilitates low-cost options, competitive pricing and fast lead times



- Volume Application Specific Pricing (VASP)** – a new program offering competitive pricing for large volume, core board-to-board production orders; for additional details, visit samtec.com/vasp

- Cost-efficient materials and components (e.g. lower-weight gold plating options to help offset the rising price of gold); learn more about Samtec's gold cost savings efforts at samtec.com/gold

UNMATCHED LEAD TIMES

Reserve[®]
SHIPS TOMORROW

- Strategic global work centers enable maximum flexibility
- Samtec Reserve**[®] – a new program with more than 200k parts that are guaranteed to ship in 1-day; for details, visit samtec.com/reserve
- Non-Reserve[®] build-to-order lead times start at 5 days for most products
- Ongoing facility expansions and additions, process optimizations; ability to quickly add capacity as needed

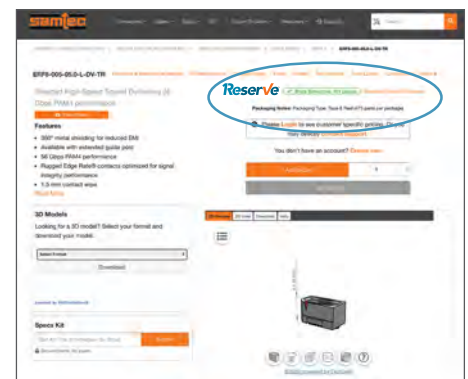

24 HOUR
SUDDEN SAMPLE[™]

Free product samples, shipped in 24-hours or less have been a cornerstone of Samtec Sudden Service[®] since the company was founded. Visit samtec.com to quickly request your sample.



24/7 WORLDWIDE ACCESS

Technical Support

Signal Integrity Group: sig@samtec.com

Application Support Group: asg@samtec.com

Interconnect Processing Group: ipg@samtec.com

Supply Chain Support

MySamtec[™] Real-Time Account Access: account.samtec.com

Personal Account Managers & CSRs: ecustomerservice@samtec.com

Upfront, Aggressive 24-Hour Quotes: pricing@samtec.com

ONLINE TOOLS

Find, Design & Validate Your Solution

PICTURE SEARCH



Browse through a highlight reel of Samtec's most popular products to find the ideal solution for your application, view specifications, check availability, order samples and more. Visit samtec.com/picturesearch.

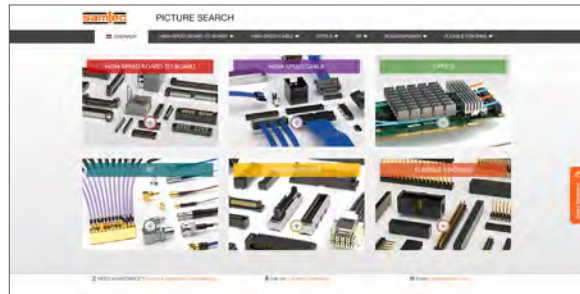

SOLUTIONATOR®

Quickly build mated connector card sets or design full cable assemblies using a wide variety of user-defined search parameters and filters, view specs and order samples.

Solutionator **HS** GET A MATED SET IN SECONDS HS TO BOARD



samtec.com/hsb2b-solutionator

Solutionator **HS** DESIGN IN A MINUTE CABLE

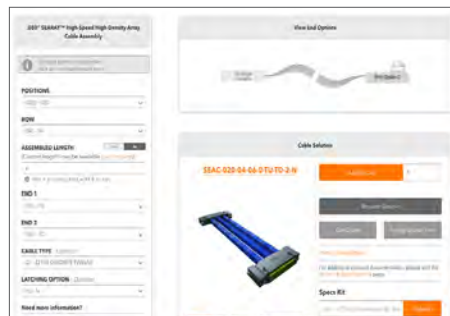

samtec.com/cablebuilder

Solutionator **RF** DESIGN IN A MINUTE CABLE



samtec.com/rf-cablebuilder

Solutionator **FLEX** GET A MATED SET IN SECONDS STACKING

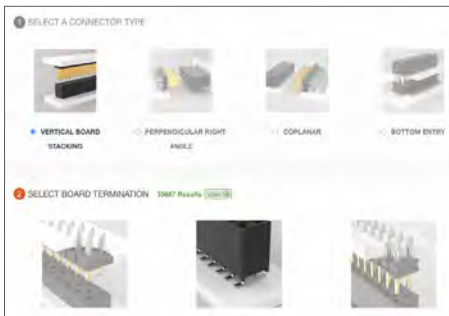

samtec.com/flex-solutionator

Solutionator **ACTIVE** DESIGN IN A MINUTE OPTICS

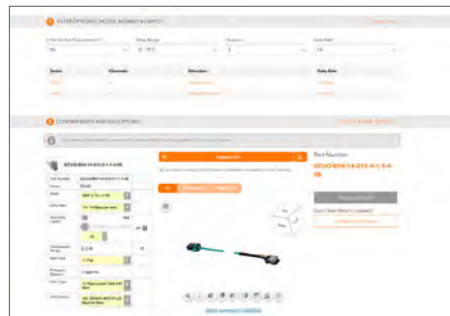

samtec.com/optics-solutionator

Solutionator **DISCRETE** DESIGN IN A MINUTE WIRE

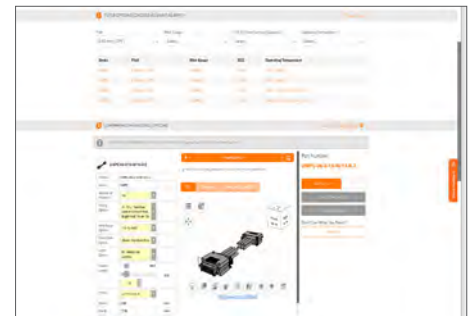

samtec.com/discrete-cablebuilder

Samtec is committed to the continuous evolution of our award-winning website, providing customers with innovative design tools, technical resources and support needed to make **finding, designing and ordering** the right product as easy and streamlined as possible. Visit samtec.com/digital-tools

DOWNLOADS

3D Models, Specs, Prints & More

3D Models

Quickly configure, preview and download models in more than 150 different formats, including AutoCad, Solid Edge, Inventor and many more.



Test Reports

Samtec provides immediate access to a variety of testing and qualification reports for our products, including high-speed characterization, thermal, frequency and time domain, Extended Life Product™, Severe Environment Testing, and others.

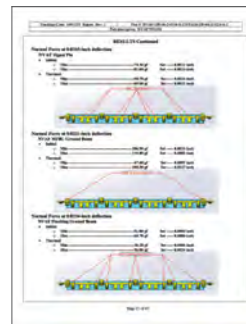

PCB Footprint / eCAD Models

Instantly view, download and design with over 200,000 ready-to-use eCAD models.

These detailed models have been formatted to work with leading schematic captures and include accurate assembly, silkscreen and 3D features.



Technical Library

Samtec's online Technical Library contains a wealth of resources, including Prints & Specifications, White Papers, Application Notes, Test Reports, Product Videos, Design Guides, Processing Information and much more.

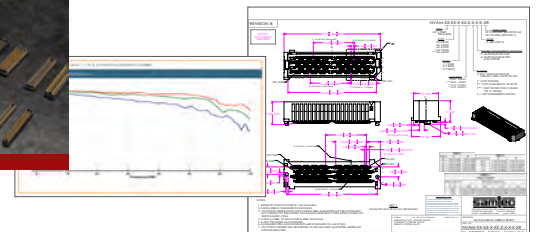
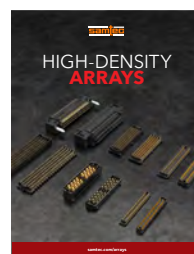

mySamtec™
account.samtec.com

Samtec's user-friendly eCommerce platform allows you to quickly and easily check product availability and pricing, as well as place and manage your orders online.

MODIFIED & CUSTOM SOLUTIONS



With dedicated Application Specific Product engineers and technicians, Samtec is open to customizing interconnects spanning every product category we offer, which includes both simple modifications as well as completely new and custom designs.

INDUSTRY-LEADING SUPPORT & EXPERTISE

Visit samtec.com/custom for details.

- Full engineering, design and prototype support
- Design, simulation and processing assistance
- Dedicated Application Specific Product engineers and technicians
- Industry-leading Customer Service
- Quotes and samples turned around in 24 hours
- Flexible, quick-turn, in-house manufacturing
- Customer specific testing - AS9102 FAIs available
- ITAR compliant with U.S. based manufacturing
- Contact the Application Specific Products Group at asp@samtec.com to discuss your application

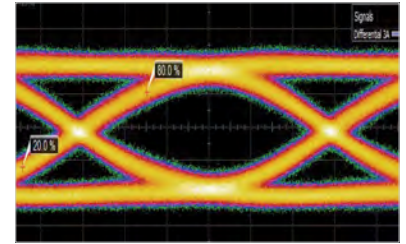

EXPRESS MODIFICATIONS & ENGINEERED CUSTOMS

- Up to 50 μ " Gold and Tin Lead plating available
- Polarized positions
- Modified stack heights, latching and screw downs
- Modified contacts, bodies, stamping, plating, wiring, molding and much more
- Ruggedizing features including strain relief, plastic housings, screw downs, latches, locks, etc.
- Mix-and-match cable end options for application specific requirements
- Many non-cataloged cable standards available, including 75 Ω micro coax & high-density twinax solutions
- Solutions for Optics in extreme environments: parylene conformal coating, mitigation for tin whiskers, fungal resistant, extreme shock and vibration, full support for liquid immersion cooling

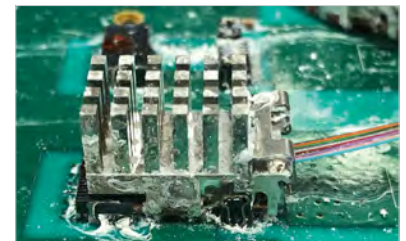
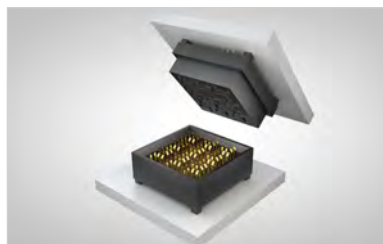

HIGH-SPEED HIGH-DENSITY ARRAYS

EXTREME DENSITY • HIGH-PERFORMANCE • MAXIMUM DESIGN FLEXIBILITY

16-17

NOVARAY® EXTREME
PERFORMANCE ARRAYS
(NVAM, NVAf)



18-19

ACCELERATE® HP
HIGH-PERFORMANCE
ARRAYS (APM6, APF6)

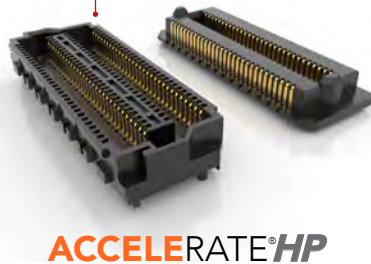

20-21

ACCELERATE® HD
HIGH-DENSITY
ARRAYS (ADM6, ADF6)

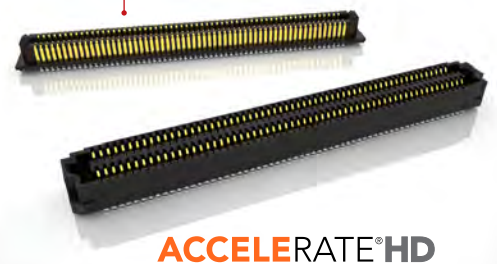

22-23

ACCELERATE® MP
POWER/SIGNAL ARRAYS
(UDM6/UDF6)

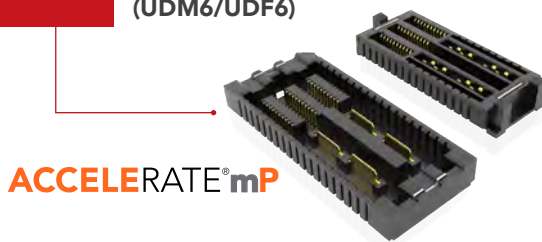

24-27

SEARAY™ 1.27 mm PITCH
OPEN-PIN-FIELD ARRAYS
(SEAF, SEAM)

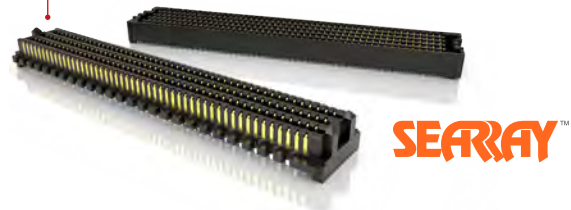

28-29

SEARAY™ 0.80 mm PITCH
OPEN-PIN-FIELD ARRAYS
(SEAM8, SEAF8)



30-31

LP ARRAY™
LOW PROFILE ARRAYS
(LPAM, LPAF)



32

SUPERNOVA™
LOW PROFILE
COMPRESSION
INTERPOSERS (GMI)

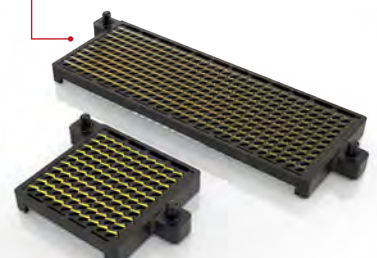

EXTREME PERFORMANCE HIGH-DENSITY ARRAYS

(0.80 mm) .0315" x (1.80 mm) .071" PITCH



FEATURES & BENEFITS

- 128 Gbps PAM4/PCIe® 7.0 capable
- 48 fully shielded differential pairs per square inch
- 4.0 Tbps aggregate data rate - 9 IEEE, 400G channels
- Extremely low crosstalk beyond 40 GHz
- Incredibly tight impedance control
- Minimal variance in data rate as stack height increases
- Utilizes 40% less space with the same data throughput as compared to traditional arrays
- Analog over Array™ capable



High-speed mezzanine connector and cable in one product family



BGA attach to board for greater density and optimized trace breakout region



Two reliable points of contact with a 1.14 mm wipe

KEY SPECIFICATIONS (NVAM/NVAF)

TOTAL PAIRS	INSULATOR MATERIAL	CONTACT MATERIAL	PLATING	OPERATING TEMP RANGE	CURRENT RATING	VOLTAGE RATING	LEAD-FREE SOLDERABLE
Up to 32 pairs	Black LCP	Copper Alloy	Au or Sn over 50 μ" (1.27 μm) Ni	-55 °C to +125 °C	2.1 A per pin (signal) 9.6 A per pin (ground)	200 VAC/283 VDC	Yes

PCI-SIG®, PCI Express® and the PCIe® design marks are registered trademarks and/or service marks of PCI-SIG.

0.80 mm x 1.80 mm PITCH • EXTREME PERFORMANCE ARRAYS

SERIES	STYLE	NO. OF ROWS	NO. OF BANKS	LEAD STYLE	PLATING OPTION	SOLDER TYPE	K	"X"R
NVAM Terminal	-DP = 4 pairs per wafer	-02	-1 = 1 Bank	-02.0 = (2 mm) .0787" (NVAM only)	-S = 30 μm (0.76 μm) Gold on contact area, Matte Tin on solder tail	-2 = Lead-Free Solder Charge	-K = (3.50 mm) .138" DIA Polyimide film Pick & Place Pad	-TR = Tape & Reel
NVAF Socket		-03	-2 = 2 Banks	-05.0 = (5 mm) .1969"				-FR = Full Reel Tape & Reel (must order maximum quantity per reel; contact Samtec for quantity breaks)
	-04		-07.0 = (7 mm) .2756" (NVAF only)					

NVAM
Board Mates:
NVAF
Standoffs:
GPSO

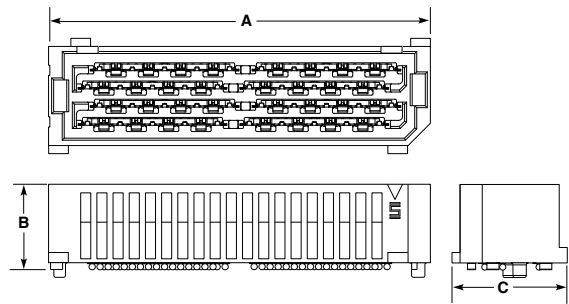

NO. OF BANKS	A	LEAD STYLE	B	NO. OF ROWS	C
-1	(21.75) .856	-02.0	(5.46) .215	-02	(7.80) .307
-2	(37.75) 1.486	-05.0	(8.46) .333	-03	(9.60) .378
				-04	(11.40) .449

View complete specifications at: samtec.com?NVAM

NVAF
Board Mates:
NVAM
Standoffs:
GPSO

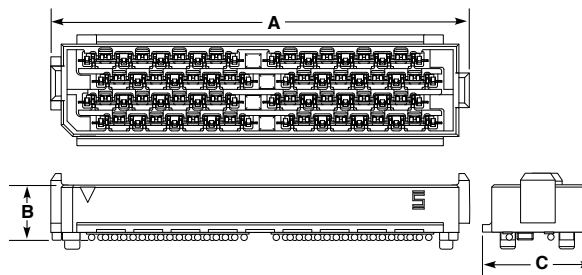
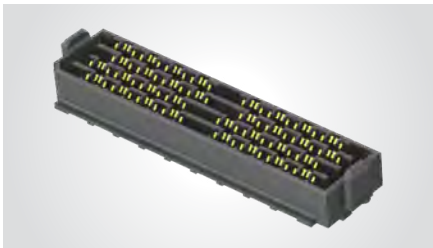

NO. OF BANKS	A
-1	(20.25) .797
-2	(36.25) 1.427

LEAD STYLE	B
-05.0	(4.80) .189
-07.0	(6.80) .268

NO. OF ROWS	C
-02	(6.00) .236
-03	(7.80) .307
-04	(9.60) .378

MATED HEIGHTS*		
NVAF LEAD STYLE	NVAM LEAD STYLE	
	-02.0	-05.0
-05.0	(7.00) .276	(10.00) .394
-07.0	(9.00) .354	(12.00) .472

*Processing conditions will affect mated height.

Notes:
Some sizes, styles and options are non-standard, non-returnable

AGGREGATE DATA RATE (NRZ)				
1024 Gbps	1536 Gbps	2048 Gbps	3072 Gbps	4096 Gbps
1 Bank		2 Bank		
2 Row	3 Row	4 Row 2 Row	3 Row	4 Row
8 Pairs	12 Pairs	16 Pairs	24 Pairs	32 Pairs

View complete specifications at: samtec.com?NVAF

ACCELERATE[®]HP

HIGH-PERFORMANCE ARRAY SYSTEM

(0.635 mm) .025" PITCH

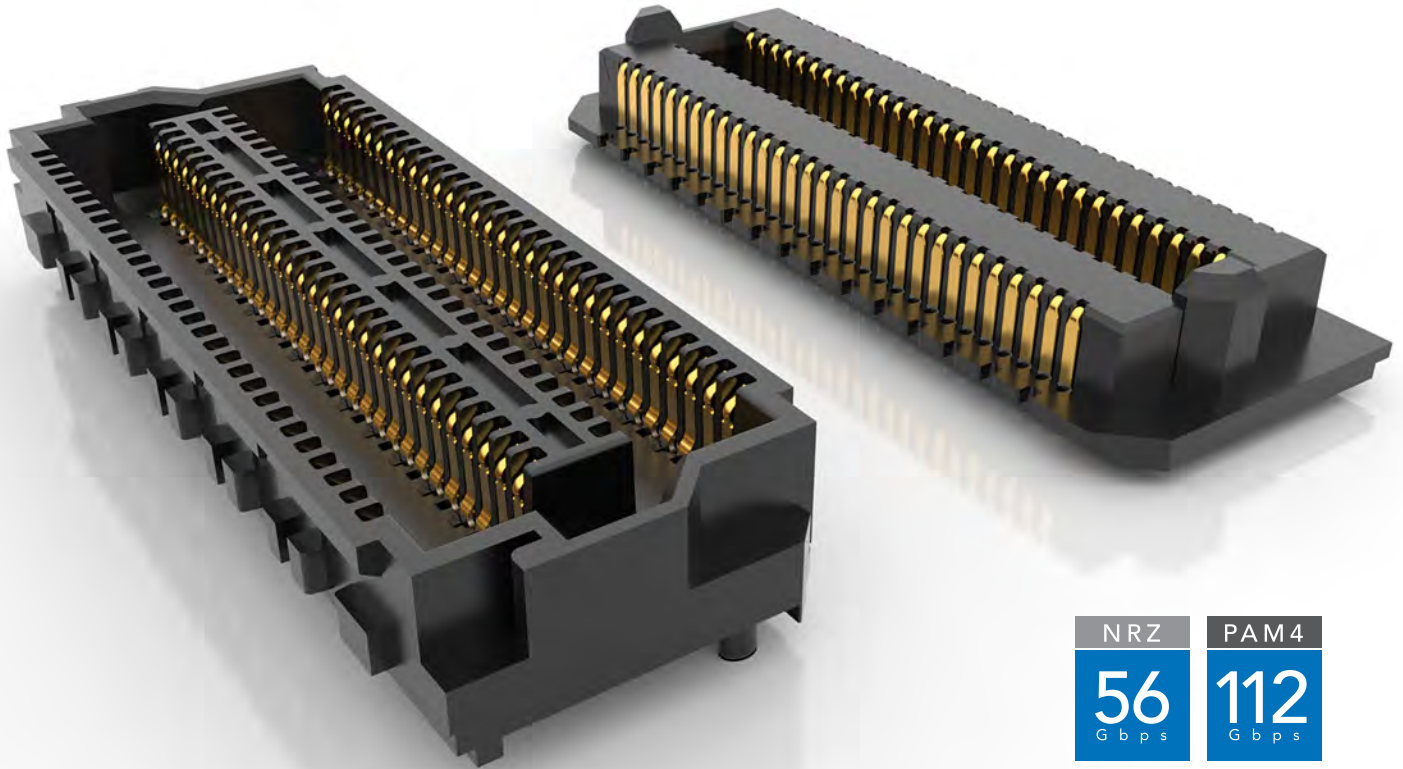

NRZ	PAM4
56 Gbps	112 Gbps

FEATURES & BENEFITS

- Flexible open-pin-field and extreme performance solution
- Low profile 5 mm and up to 10 mm stack heights
- 0.635 mm pitch
- Up to 800 total pins; roadmap to 1,000+ pins
- Data rate compatible with PCIe[®] 6.0/CXL[®] 3.2 and 100 GbE
- Analog over Array[™] capable
- Road Map: 6 and 10 rows, additional position counts



Right-angle connector
(samtec.com?APF6-RA)

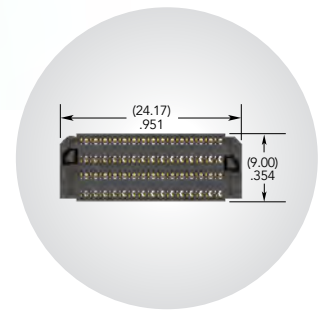

APF6 Series; 120 pins

KEY SPECIFICATIONS (APM6/APF6)

TOTAL PINS	INSULATOR MATERIAL	CONTACT MATERIAL	PLATING	OPERATING TEMP RANGE	CURRENT RATING	VOLTAGE RATING	LEAD-FREE SOLDERABLE
40 - 800	Black LCP	Copper Alloy	Au or Sn over 50 μ" (1.27 μm) Ni	-55 °C to +125 °C	1.2 A (4 pins powered)	150 VAC/212 VDC	Yes

PCI-SIG[®], PCI Express[®] and the PCIe[®] design marks are registered trademarks and/or service marks of PCI-SIG.

(0.635 mm) .025" PITCH • 112 Gbps PAM4 OPEN-PIN-FIELD ARRAYS

SERIES	NO. OF POSITIONS	LEAD STYLE	PLATING OPTION	NO. OF ROWS	0	OPTION	"X"R
APM6 Terminal	-020, -040, -060, -100 (per row)	-01.5 = 1.5 mm (APM6 only)	-L = 10 μ" (0.25 μm) Gold on contact area, Matte Tin on tail	-04 = Four Rows	0	(Leave blank for no alignment pin)	-TR = Tape & Reel
APF6 Socket		-01.9 = 1.9 mm (APM6 only) (Only mates with an APF6-RA)		-08 = Eight Rows (Lead Style -01.5 & -03.5 with 100 Positions only)			
		-06.5 = 6.5 mm (APM6 only)					
		-03.5 = 3.5 mm (APF6 only)				-A = Alignment Pin	-FR = Full Reel Tape & Reel (must order max. quantity per reel; contact Samtec for quantity breaks)

APM6 Board Mates:
APF6, APF6-RA

Standoffs:
GPSO

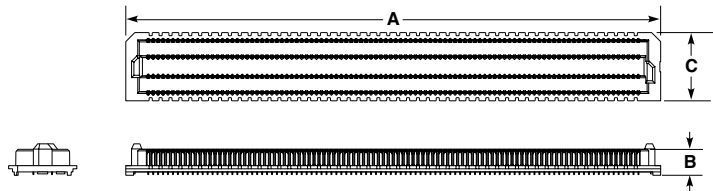
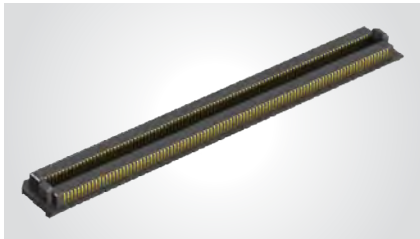

NO. OF POSITIONS PER ROW	A	LEAD STYLE	B	NO. OF ROWS	C
-020	(17.82) .701	-01.5	(3.33) .131	-04	(8.75) .344
-040	(30.52) 1.201	-01.9	(3.71) .146	-08	(17.95) .707
-060	(43.22) 1.701	-06.5	(8.33) .328		
-100	(68.62) 2.701				

ALSO AVAILABLE
Contact Samtec

Other platings

View complete specifications at: samtec.com?APM6

MATED HEIGHTS *		
APF6 LEAD STYLE	APM6 LEAD STYLE	
	-01.5	-06.5
-03.5	(5.00 mm) .197"	(10.00 mm) .394"

* Processing conditions will affect mated height.

APF6 Board Mates:
APM6

Standoffs:
GPSO

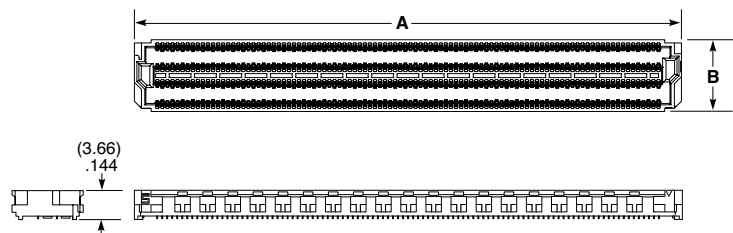
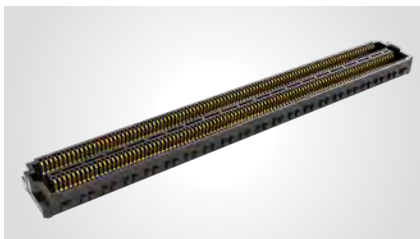

OTHER SOLUTIONS

Right-angle
samtec.com?APF6-RA

NO. OF POSITIONS PER ROW	A	NO. OF ROWS	B
-020	(17.82) .701	-04	(9.00) .354
-040	(30.52) 1.201	-08	(18.20) .717
-060	(43.22) 1.701		
-100	(68.62) 2.701		

Notes:
Some sizes, styles and options are non-standard, non-returnable

View complete specifications at: samtec.com?APF6

ACCELERATE[®] HD

HIGH-DENSITY SLIM BODY ARRAYS

(0.635 mm) .025" PITCH

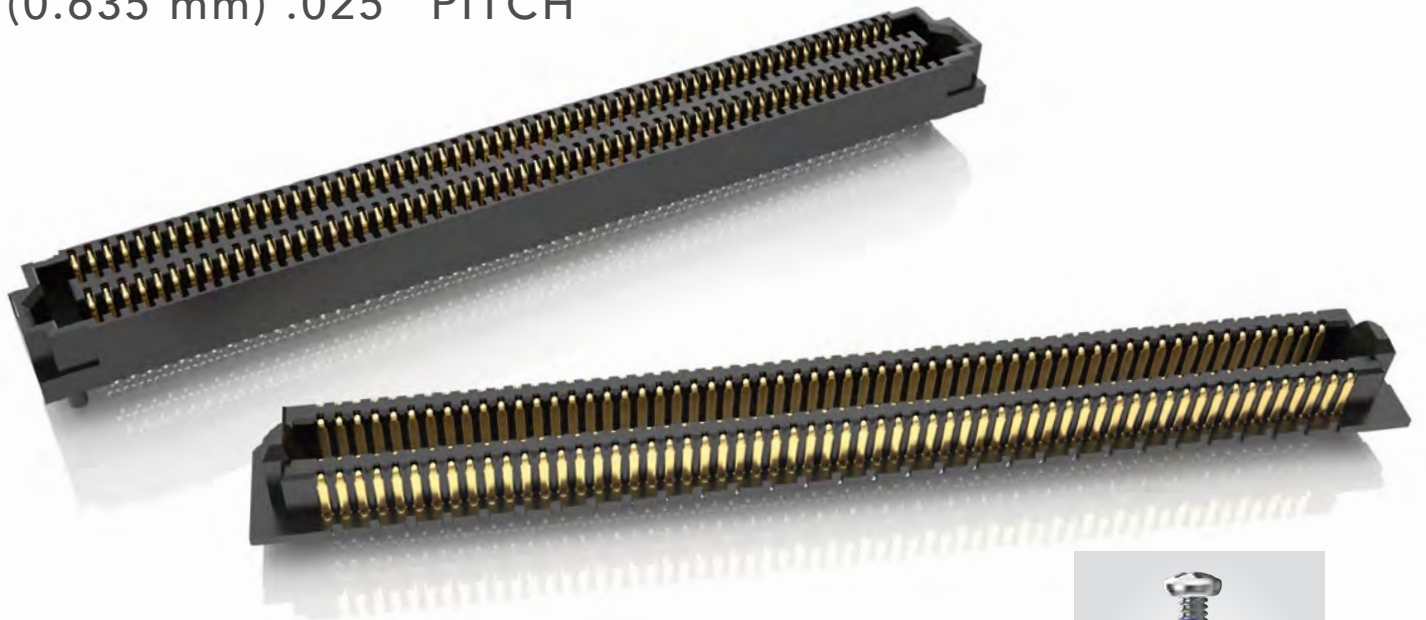

FEATURES & BENEFITS

- Up to 400 positions in a 4-row design
- 5 mm, 7 mm, 9 mm, 10 mm, 11 mm, 12 mm, 14 mm & 16 mm stack heights
- Slim 5 mm width body design
- Edge Rate[®] contact system optimized for signal integrity performance
- Open-pin-field for grounding and routing flexibility
- Supports 64 Gbps PAM4 (32 Gbps NRZ) applications
- PCIe[®] 6.0/CXL[®] 3.2 capable

PAM4

64
Gbps



SureWare[™] ultra rugged guide post standoffs available (GPSO)

HIGHER DENSITY THAN PREVIOUS GENERATION STRIPS

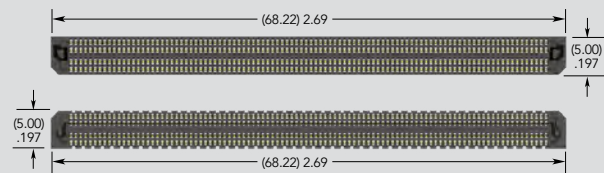

ADM6/ADF6 Series (400 total positions)

KEY SPECIFICATIONS (ADM6/ADF6)

PITCH	TOTAL POSITIONS	INSULATOR MATERIAL	CONTACT MATERIAL	PLATING	OPERATING TEMP RANGE	CURRENT RATING	VOLTAGE RATING	LEAD-FREE SOLDERABLE
(0.635 mm) .025"	40 - 400	Black LCP	Copper Alloy	Au or Sn over 50 μ" (1.27 μm) Ni	-55 °C to +125 °C	1.34 A per pin (4 pins powered)	155 VAC/219 VDC	Yes

PCI-SIG[®], PCI Express[®] and the PCIe[®] design marks are registered trademarks and/or service marks of PCI-SIG.

(0.635 mm) .025" PITCH • SLIM BODY OPEN-PIN-FIELD ARRAYS

SERIES	NO. OF POSITIONS	LEAD STYLE	PLATING OPTION	NO. OF ROWS	0	OPTION	"X"R
ADM6 Terminal	-10, -20, -30, -40, -50, -60, (per row)	-01.5 = 1.5 mm (ADM6 only)	-L = 10 μ" (0.25 μm) Gold on contact area, Matte Tin on tail	-4 = Four Rows		(Leave blank for no alignment pin)	-TR = Tape & Reel
ADF6 Socket	-70, -80, -90, -100 (ADF6-03.5 & ADM6-01.5, -03.5 & -06.5 lead styles only)	-03.5 = 3.5 mm				-A = Alignment Pin	-FR = Full Reel Tape & Reel (must order max. quantity per reel; contact Samtec for quantity breaks)
		-06.5 = 6.5 mm (ADM6 only)					
		-07.5 = 7.5 mm (ADF6 only)					
		-08.5 = 8.5 mm (ADM6 only)					

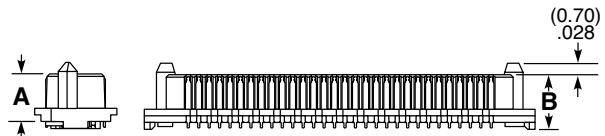
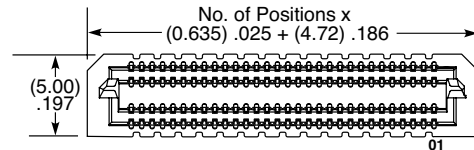

ADM6

Board Mates:
ADF6

Standoffs:
JSO, GPSO

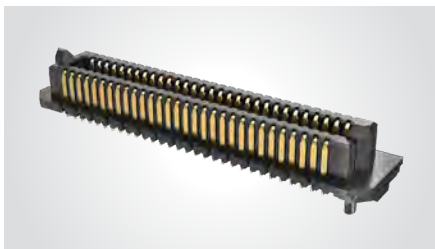

LEAD STYLE	A	B
-01.5	(2.90) .114	(3.32) .131
-03.5	(4.90) .193	(5.32) .209
-06.5	(7.90) .311	(8.32) .328
-08.5	(9.90) .390	(10.32) .406

ALSO AVAILABLE
Contact Samtec

Other platings

View complete specifications at: samtec.com?ADM6

MATED HEIGHTS *

ADF6 LEAD STYLE	ADM6 LEAD STYLE			
	-01.5	-03.5	-06.5	-08.5
-03.5	(5 mm) .197"	(7 mm) .276"	(10 mm) .394"	(12 mm) .472"
-07.5	(9 mm) .354"	(11 mm) .433"	(14 mm) .551"	(16 mm) .630"

* Processing conditions will affect mated height.

ADF6

Board Mates:
ADM6

Standoffs:
JSO, GPSO

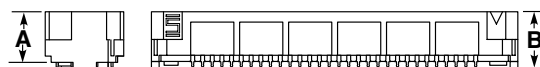
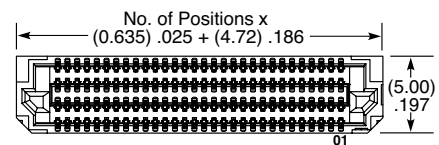
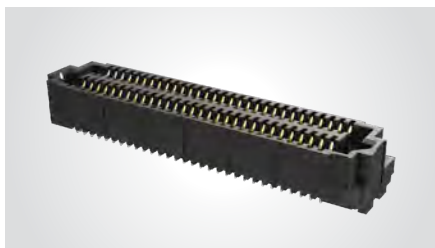

LEAD STYLE	A	B
-03.5	(3.23) .127	(3.65) .144
-07.5	(7.23) .285	(7.65) .301

Notes:

Some sizes, styles and options are non-standard, non-returnable

View complete specifications at: samtec.com?ADF6

ACCELERATE[®]mP

HIGH-DENSITY, HIGH-SPEED POWER/SIGNAL ARRAYS

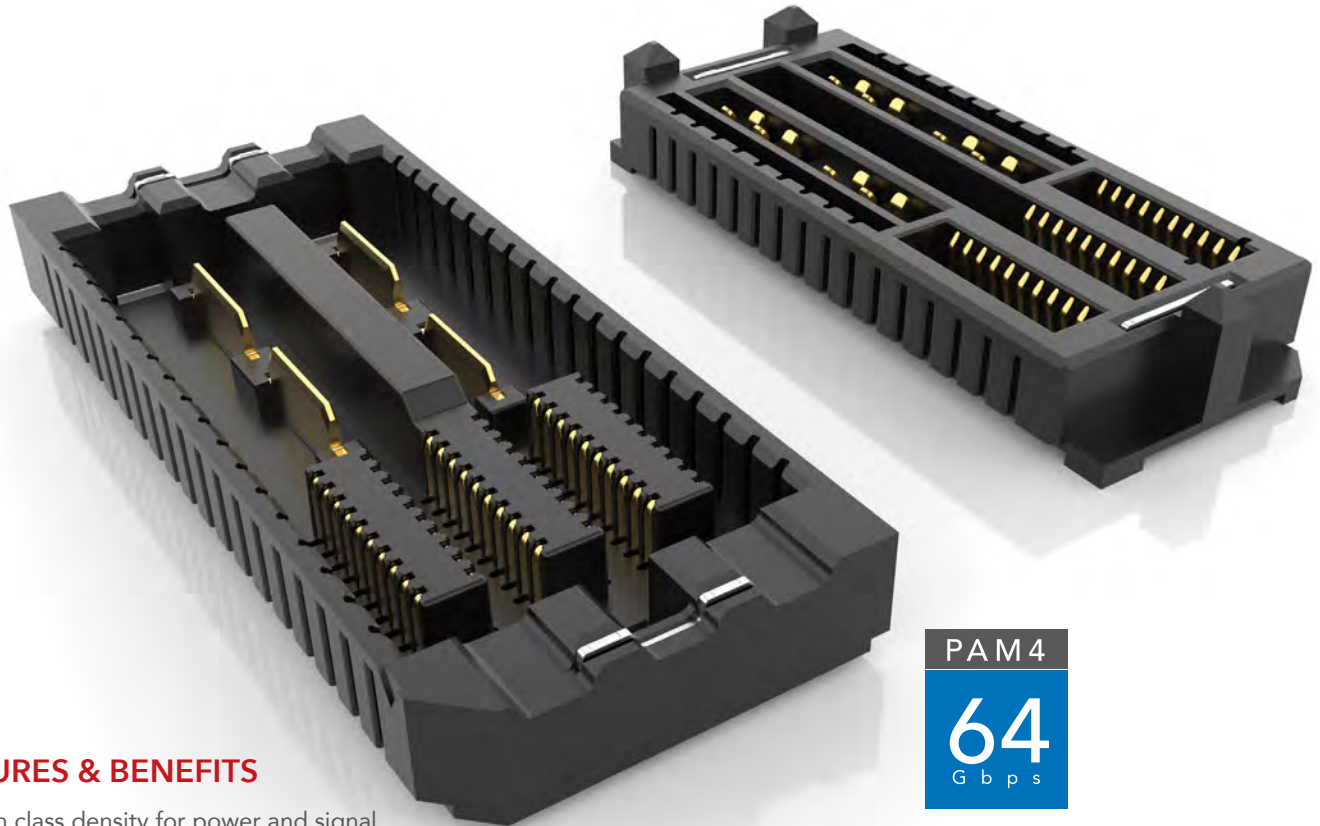

FEATURES & BENEFITS

- Best in class density for power and signal
- Rotated power blades simplify breakout region (BOR)
- Open-pin-field design for routing and grounding flexibility
- Low profile 5 mm stack height; up to 16 mm in development
- Up to 8 power and 240 signal positions; additional position counts in development
- 0.635 mm signal pitch
- Supports 64 Gbps PAM4 (32 Gbps NRZ) applications
- PCIe[®] 6.0/CXL[®] 3.2 capable
- Weld tabs included for a secure connection to the board
- Polarized guide posts for blind mating
- Optional alignment pins

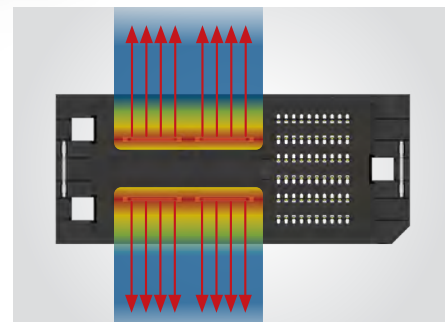

Blades rotated 90° have equal access to heat escape for uniform cooling and simplified breakout region (BOR)

KEY SPECIFICATIONS (UDM6/UDF6)

PITCH	STACK HEIGHTS	INSULATOR MATERIAL	CONTACT MATERIAL	PLATING	OPERATING TEMP RANGE	CURRENT RATING	VOLTAGE RATING	LEAD-FREE SOLDERABLE
0.635 mm (Signal) 6.00 mm (Power)	5 mm	Black LCP	Copper Alloy	Au or Sn over 50 μ" (1.27 μm) Ni	-55 °C to +125 °C	15 A per power pin	200 VAC/ 283 VDC	Yes

PCI-SIG[®], PCI Express[®] and the PCIe[®] design marks are register trademarks and/or service marks of PCI-SIG.

(0.635 mm) .025" PITCH • UDM6/UDF6 SERIES

UDM6	NO. OF SIGNAL POSITIONS	NO. OF POWER POSITIONS	LEAD STYLE	PLATING OPTION	OPTION	WELD TAB	"X"R
	-10, -40 (Per Row)	-2, -4 (Per Row)	-01.5 = 1.5 mm	-L = 10 μ" (0.25 μm) Gold on contact area, Matte Tin on tail	(Leave blank for no alignment pin) -A = Alignment Pin	-TH = Through-Hole	-TR = Tape & Reel -FR = Full Reel Tape & Reel (must order max. quantity per reel; contact Samtec for quantity breaks)

UDM6

Board Mates:
UDF6

Standoffs:
GPSO

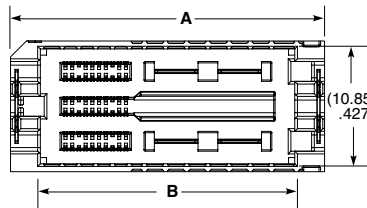

NO. OF SIGNAL PER ROW	NO. OF POWER PER ROW	A	B
-010	-2	(29.68) 1.168	(24.42) .961
-040	-4	(60.73) 2.391	(55.47) 2.184

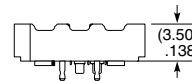
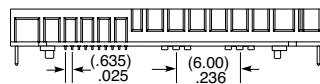

UDM6-10-2-01.5-X-A-TH-XR
(Some center features removed for clarity)

ALSO AVAILABLE
Contact Samtec

Other platings

Notes:

Some sizes, styles and options are non-standard, non-returnable

View complete specifications at: samtec.com?UDM6

UDF6	NO. OF SIGNAL POSITIONS	NO. OF POWER POSITIONS	LEAD STYLE	PLATING OPTION	OPTION	WELD TAB	"X"R
	-10, -40 (Per Row)	-2, -4 (Per Row)	-03.5 = 3.5 mm	-L = 10 μ" (0.25 μm) Gold on contact area, Matte Tin on tail	(Leave blank for no alignment pin) -A = Alignment Pin	-TH = Through-Hole	-TR = Tape & Reel -FR = Full Reel Tape & Reel (must order max. quantity per reel; contact Samtec for quantity breaks)

UDF6

Board Mates:
UDM6

Standoffs:
GPSO

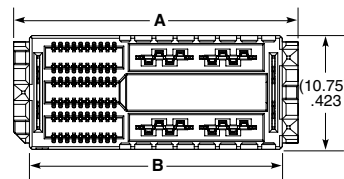

NO. OF SIGNAL PER ROW	NO. OF POWER PER ROW	A	B
-010	-2	(26.88) 1.058	(23.90) .941
-040	-4	(57.93) 2.281	(54.95) 2.163

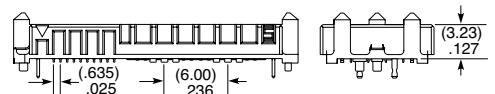

UDF6-10-2-03.5-X-A-TH-XR
(Some center features removed for clarity)

ALSO AVAILABLE
Contact Samtec

Other platings

Notes:

Some sizes, styles and options are non-standard, non-returnable

View complete specifications at: samtec.com?UDF6



HIGH-DENSITY OPEN-PIN-FIELD ARRAYS

(1.27 mm) .050" PITCH

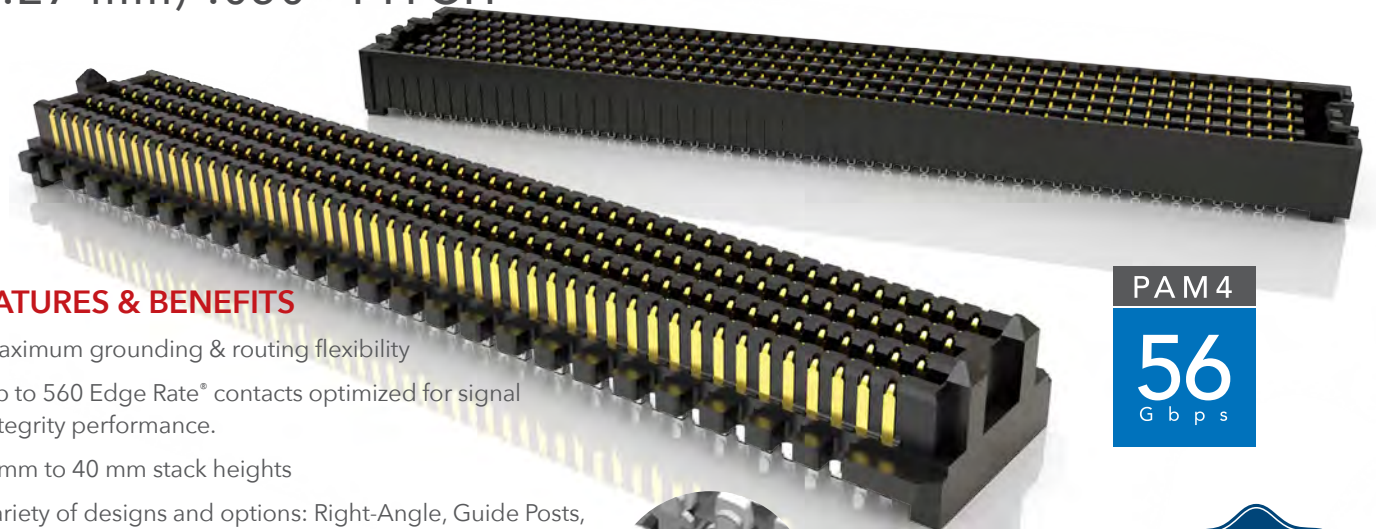

FEATURES & BENEFITS

- Maximum grounding & routing flexibility
- Up to 560 Edge Rate® contacts optimized for signal integrity performance.
- 7 mm to 40 mm stack heights
- Variety of designs and options: Right-Angle, Guide Posts, 85 Ω Elevated Risers, 85 Ω Tuned, Press-Fit and Press-Fit Right-Angle, Guide Post Field Termination Kits
- Cable mates (SEAC Series) and Jack Screw Standoffs (JSO Series) also available
- Analog over Array™ capable
- Standards: VITA™ 47, VITA™ 57.1 FMC™, VITA™ 57.4 FMC™+, VITA™ 74 VNX™, PISMO™ 2
- Supports high-speed protocols such as Ethernet, PCI Express®, Fibre Channel & InfiniBand™
- Severe Environment Testing qualified (SEAM/SEAF); aligns with MIL-DTL-55302. Visit samtec.com/set

VITA/VNX/VNX+/FMC/FMC+/XMC/XMC+ are all respective trademarks of VITA PCI-SIG®.

The PCI Express® design marks are registered trademarks and/or service marks of PCI-SIG.



Solder Charges

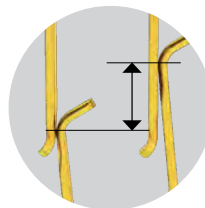

(1.12 mm) .044" Nominal Wipe

MAXIMUM GROUNDING & ROUTING FLEXIBILITY

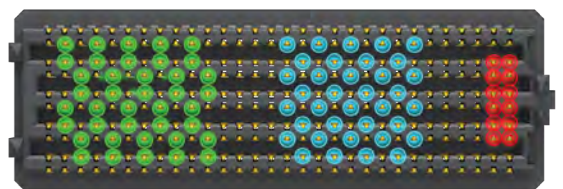

Differential Pair Single-Ended Power

SERIES	INSULATOR MATERIAL	CONTACT MATERIAL	PLATING	OPERATING TEMP RANGE	CURRENT RATING	VOLTAGE RATING	LEAD-FREE SOLDERABLE
SEAM/SEAF	Black LCP	Copper Alloy	Au or Sn over 50 μ" (1.27 μm) Ni	-55 °C to +125 °C	2.7 A (10 pins powered)	240 VAC/339 VDC	Yes
SEAM-RA/SEAF-RA	Black LCP	Copper Alloy	Au or Sn over 50 μ" (1.27 μm) Ni	-55 °C to +125 °C	1.9 A (10 pins powered)	240 VAC/339 VDC	Yes
SEAM-GP	Black LCP	Copper Alloy	Au or Sn over 50 μ" (1.27 μm) Ni	-55 °C to +125 °C	2.7 A (10 pins powered)	240 VAC/339 VDC	Yes
SEAMP/SEAFP	Natural High Temp Nylon	Copper Alloy (SEAMP) BeCu Alloy (SEAFP)	Au or Sn over 50 μ" (1.27 μm) Ni	-55 °C to +125 °C	1.9 A (6 pins powered)	255 VAC/361 VDC	Not Available
SEAR	Black LCP	Hard Gold Plated	Au over 50 μ" (1.27 μm) Ni	-55 °C to +125 °C	1.4 A (20 pins powered)	240 VAC/339 VDC	Not Available
SEAMI	Black LCP	Copper Alloy	Au or Sn over 50 μ" (1.27 μm) Ni	-55 °C to +125 °C	Not Available	Not Available	Yes

Note: Some lengths, styles and options are non-standard, non-returnable

(1.27 mm) .050" PITCH • SEAM/SEAF SERIES

SERIES	POSITIONS PER ROW	LEAD STYLE	PLATING OPTION	NO. OF ROWS	SOLDER TYPE	A	K	"X" R
SEAM Terminal	-10, -15, -20, -30, -40, -50	Specify LEAD STYLE from chart	-L = 10 μ" (0.25 μm) Gold on contact area, Matte Tin on solder tail	-04	-1 = Tin/ Lead Alloy Solder Charge			
SEAF Socket	SEAM & SEAF: -10 only available in -04 Row		-P = SureCoat™ 3 μ" (0.07 μm) Gold Flash and 30 μ" (0.76 μm) Palladium Nickel on contact area, Matte Tin on solder tail (-02.0, -03.5, -05.0 & SEAF-06.5 Lead Styles only)	-05 -06 -08 -10	-2 = Lead-Free Solder Charge			
	SEAM: -15 only available in -04 Row with -02.0 Lead Style, and -10 Row with any Lead Style			(SEAM -05 Rows not available with -06.5 Lead Style)				-A = Alignment Pin
	SEAF: -15 only available in -04 or -10 Row with -5.0 Lead Style							-K Polyimide Film Pick & Place Pad
								-TR = Tape & Reel
								-FR = Full Reel Tape & Reel (must order max. quantity per reel; contact Samtec for quantity breaks)

NO. OF ROWS	B
-04	(7.06) .278
-05, -06	(9.60) .378
-08	(12.14) .478
-10	(14.68) .578

SEAM
Board Mates:
SEAF, SEAFP
Standoffs:
JSO

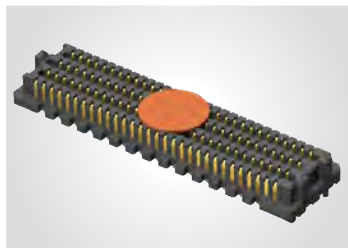

LEAD STYLE	A
-02.0	(5.61) .221
-03.0	(6.60) .260
-03.5	(7.11) .280
-06.5	(10.16) .400
-07.0	(10.59) .417
-09.0	(12.60) .496
-11.0	(14.61) .575

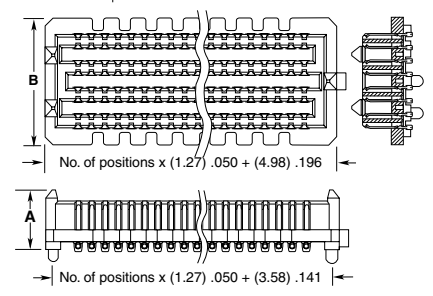

ALSO AVAILABLE
Contact Samtec
Other platings

OTHER SOLUTIONS
See website for 14 row option.

View complete specifications at: samtec.com?SEAM

SEAF
Board Mates:
SEAM, SEAMP,
SEAR, SEAMI
Standoffs:
JSO

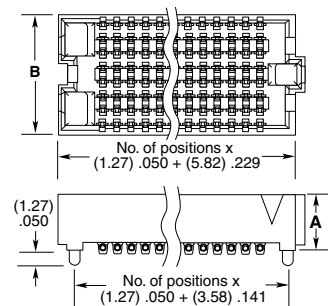
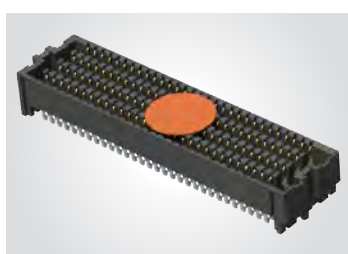

LEAD STYLE	A	NO. OF ROWS	B
-05.0	(5.05) .199	-04	(5.66) .223
-06.0	(6.05) .238	-05, -06	(8.20) .323
-06.5	(6.55) .258	-08	(10.74) .423
-07.5	(7.54) .297	-10	(13.28) .523

View complete specifications at: samtec.com?SEAF

STANDARDS

VITA™ 47
VITA™ 57.1 FMC™
VITA™ 57.4 FMC+™
VITA™ 74 VNX™
PISMO™ 2

Visit www.samtec.com/standards for more information.

SEAM LEAD STYLE	SEAF LEAD STYLE			
	-05.0	-06.0	-06.5	-07.5
-02.0	7 mm	8 mm	8.5 mm	9.5 mm
-03.0	8 mm	9 mm	9.5 mm	10.5 mm
-03.5	8.5 mm	9.5 mm	10 mm	11 mm
-06.5	11.5 mm	12.5 mm	13 mm	14 mm
-07.0	12 mm	13 mm	13.5 mm	14.5 mm
-09.0	14 mm	15 mm	15.5 mm	16.5 mm
-11.0	16 mm	17 mm	17.5 mm	18.5 mm

Notes:
IPC-A-610F and IPC J-STD-001F Class 3 solder joint.
Severe Environment Testing qualified; aligns with MIL-DTL-55302. Visit samtec.com/set
VITA/VNX/VNX+/FMC/FMC+/XMC/XMC+ are all respective trademarks of VITA

(1.27 mm) .050" PITCH • RIGHT-ANGLE & GUIDE POST

SERIES	POSITIONS PER ROW	01	PLATING OPTION	NO. OF ROWS	SOLDER TYPE	RA	OPTIONS	"X"R
SEAM Right-Angle Terminal	-20		-L = 10 μ" (0.25 μm) Gold on contact area, Matte Tin on solder tail	-04	-1 = Tin/Lead Alloy Solder Charge		-GP = Guide Post/Hole	-TR = Tape & Reel
	-30			-06			-2 = Lead-Free Solder Charge	-K = Polyimide Film Pick & Place Pad
SEAF Right-Angle Socket	-40			-08	-08 & -10 Row options require fixturing to process		-10	-LP Latch Post (Available with SEAF in -06 Row with 30 positions only; Required for mating to SEAC)
	-50							

SEAM-RA

Board Mates:
SEAF, SEAF-RA, SEAFP

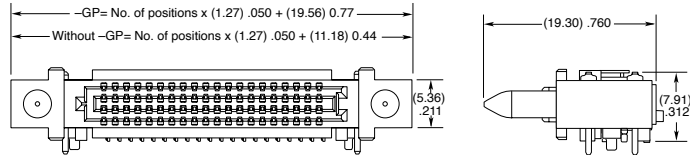
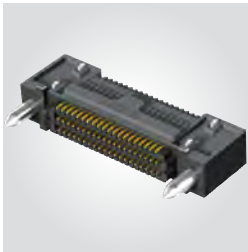

SEAF-RA

Board Mates:
SEAM, SEAMP

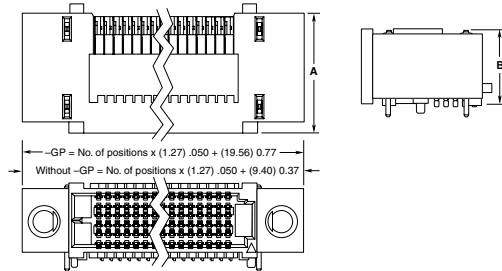

NO. PINS PER ROW	A	B
-04	(13.77) .542	(7.91) .311
-06	(16.31) .642	(10.45) .411
-08	(18.85) .742	(12.99) .511
-10	(21.39) .842	(15.53) .611

View complete specifications at: samtec.com?SEAM-RA & samtec.com?SEAF-RA

SERIES	POSITIONS PER ROW	02.0	PLATING OPTION	NO. OF ROWS	SOLDER TYPE	A	GP	K	"X"R
SEAM Terminal with Guide post	-20, -30, -40, -50		-L = 10 μ" (0.25 μm) Gold on contact area, Matte Tin on solder tail	-04	-1 = Tin/Lead Alloy Solder Charge				-TR = Tape & Reel
				-06					-2 = Lead-Free Solder Charge
SEAM-GP	-08			-08 & -10 Row options require fixturing to process	-10				

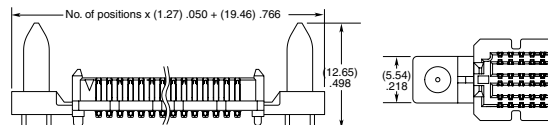
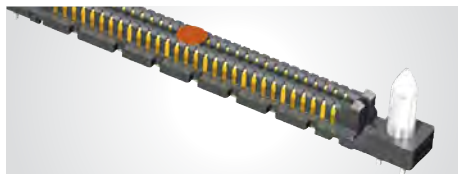

View complete specifications at: samtec.com?SEAM

Note: Some lengths, styles and options are non-standard, non-returnable

(1.27 mm) .050" PITCH • PRESS-FIT & 85 Ω OPEN-PIN-FIELD ARRAYS

SERIES	POSITIONS PER ROW	LEAD STYLE	PLATING OPTION	NO. OF ROWS	OPTION	PACKAGING
SEAMP Terminal	-10, -20, -30, -40, -50	-02.0 (SEAMP only)	-L = 10 μm (0.25 μm) Gold on contact area, Matte Tin on tail	-04, -06, -08, -10	-GP Guide Post (SEAMP only)	-TR = Tape & Reel
SEAFP Socket		-05.0 (SEAFP only)		SEAFP: -04 & -06 Rows only		-FR = Full Reel Tape & Reel (must order max. quantity per reel; contact Samtec for quantity breaks)

SEAMP
Board Mates:
SEAF,
SEAF-RA-GP,
SEAFP

NO. OF ROWS	A
-04	(7.06) .278
-06	(9.60) .378
-08	(12.14) .478
-10	(14.68) .578

SEAFP
Board Mates:
SEAM,
SEAM-RA,
SEAMP

NO. OF ROWS	A
-04	(5.61) .221
-06	(8.15) .321

View complete specifications at: samtec.com?SEAMP & samtec.com?SEAFP. Visit samtec.com?SEAFP-RA for right-angle socket.

SERIES	POSITIONS PER ROW	LEAD STYLE	NO. OF ROWS	085
SEAR 85 Ω Tuned Riser	-40, -50	-10.0 = 20 mm Mated Height -20.0 = 30 mm Mated Height -30.0 = 40 mm Mated Height	-06, -08, -10	

SEAR
Board Mates:
SEAFC

POSITIONS PER ROW	A
-40	(71.42) 2.812
-50	(84.12) 3.312

NO. OF ROWS	B
-06	(11.43) .450
-08	(13.97) .550
-10	(16.51) .650

SERIES	POSITIONS PER ROW	11.0	PLATING OPTION	NO. OF ROWS	SOLDER TYPE	A	K	"X"R
SEAMI 85 Ω Tuned Terminal	-40, -50		-L = 10 μm (0.25 μm) Gold on contact area, Matte Tin on solder tail	-08 -10	-1 = Tin/Lead Alloy Solder Charge -2 = Lead-Free Solder Charge			-TR = Tape & Reel -FR = Full Reel Tape & Reel (must order max. quantity per reel; contact Samtec for quantity breaks)

SEAMI
Board Mates:
SEAF

Note: Some lengths, styles and options are non-standard, non-returnable

NO. OF ROWS	A
-08	(13.41) .528
-10	(15.95) .628

View complete specifications at: samtec.com?SEAR & samtec.com?SEAMI.

SEARAY™ .8mm

ULTRA HIGH-DENSITY, HIGH-SPEED OPEN-PIN-FIELD ARRAYS

(0.80 mm) .0315" PITCH

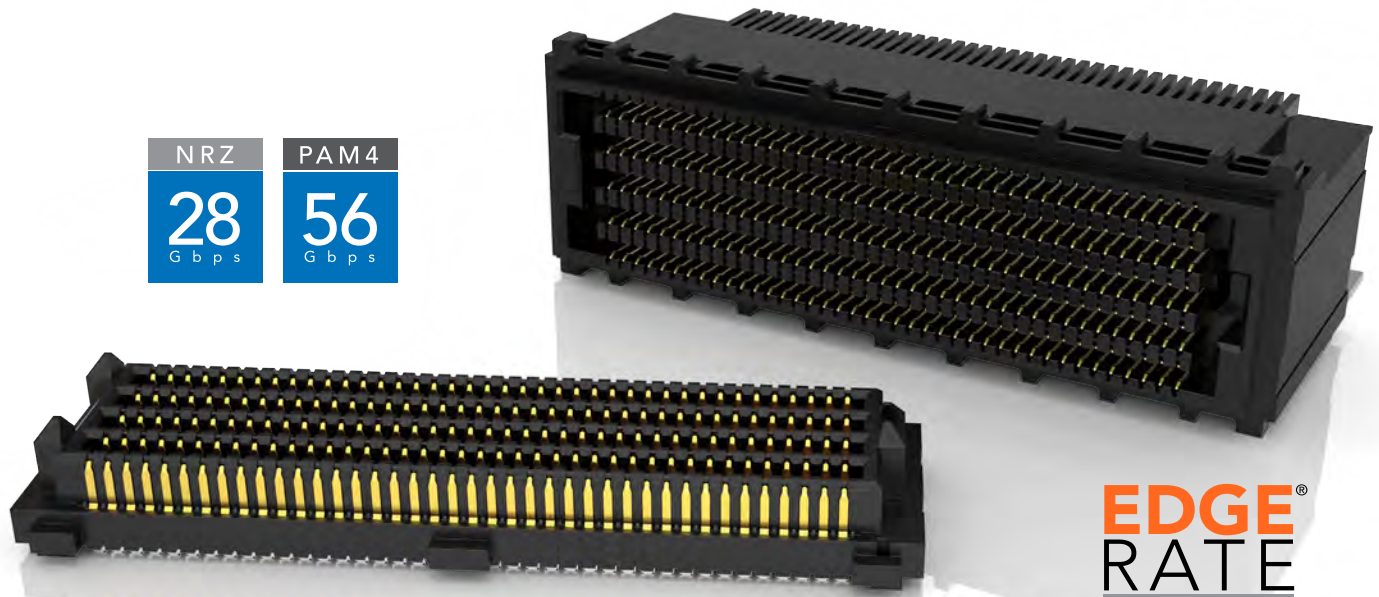
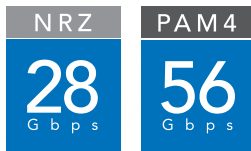

EDGE RATE®
CONTACT

FEATURES & BENEFITS

- 0.80 mm (.0315") pitch grid
- 50% board space savings versus .050" (1.27 mm) pitch arrays
- Performance up to 28 Gbps NRZ/56 Gbps PAM4
- Rugged Edge Rate® contact system
- Up to 500 I/Os
- 7 mm and 10 mm stack heights
- Solder charge terminations for ease of processing
- Lower insertion/withdrawal forces
- Analog over Array™ capable
- Severe Environment Testing qualified (SEAM8/SEAF8); aligns with MIL-DTL-55302.

Visit samtec.com/set

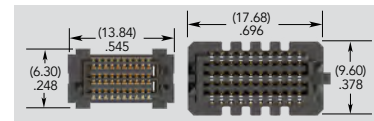

0.80 mm pitch vs. 1.27 mm pitch (60 pins shown)

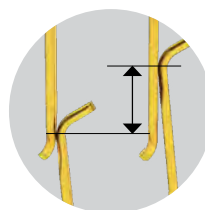

(0.95 mm) .037" Nominal Wipe

MAXIMUM GROUNDING & ROUTING FLEXIBILITY

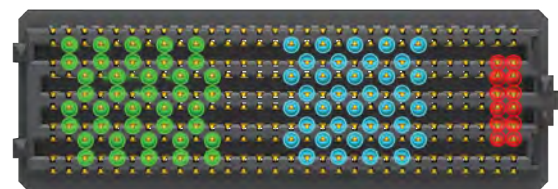

Differential Pair Single-Ended Power

KEY SPECIFICATIONS (SEAF8/SEAM8)

SERIES	INSULATOR MATERIAL	CONTACT MATERIAL	PLATING	OPERATING TEMP RANGE	CURRENT RATING	VOLTAGE RATING	LEAD-FREE SOLDERABLE
SEAM8	Black LCP	Copper Alloy	Au or Sn over 50 μ" (1.27 μm) Ni	-55 °C to +125 °C	1.3 A per pin (10 adjacent pins powered)	220 VAC/311 VDC	Yes
SEAF8					1.1 A per pin (10 adjacent pins powered)		
SEAF8-RA							

(0.80 mm) .0315" PITCH • ULTRA HIGH-DENSITY ARRAYS

SERIES	NO. PINS PER ROW	LEAD STYLE	PLATING OPTION	NO. OF ROWS	SOLDER TYPE	OPTION	"X"R
SEAM8 Terminal	-10, -20, -30, -40, -50	-S02.0 = 2 mm Body Height (SEAM8 only)	-L = 10 μ" (0.25 μm) Gold on contact area, Matte Tin on solder tail	-04 -06 -08 -10	-3 = Lead-Free Solder Crimp	-GP = Guide Post (-S02.0 lead style only) (Mates with SEAF8-RA-GP)	Tape & Reel is standard. Leave blank for Tape & Reel. -FR = Full Reel Tape & Reel (must order max. quantity per reel; contact Samtec for quantity breaks)
SEAF8 Socket		-S05.0 = 5 mm Body Height (SEAM8 only)					
		-05.0 = 5 mm Body Height (SEAF8 only)					

NO. OF ROWS	A
-04	(4.30) .169
-06	(6.30) .248
-08	(8.30) .327
-10	(10.30) .406

LEAD STYLE	B
-S02.0	(4.54) .179
-S05.0	(7.54) .297

View complete specifications at: samtec.com?SEAM8

SEAF8
Board Mates: SEAM8
Cable Mates: ESCA
Standoffs: JSO

View complete specifications at: samtec.com?SEAM8

MATED HEIGHTS*		
SEAF8 LEAD STYLE	SEAM8 LEAD STYLE	
		-S02.0
-05.0	(7.00) .276	(10.00) .394

*Processing conditions will affect mated height.

Notes:
Polyimide Pick & Place Pad standard without specifying -K.

Severe Environment Testing qualified; aligns with MIL-DTL-55302. Visit samtec.com/set

View complete specifications at: samtec.com?SEAF8

SEAF8	NO. PINS PER ROW	1	PLATING OPTION	NO. OF ROWS	SOLDER TYPE	RA	OPTION	"X"R
	-20, -30, -40, -50		-S = 30 μ" (0.76 μm) Gold on contact area, Matte Tin on solder tail	-04 (-50 positions only) -08 -10	-2 = Lead-Free Solder Crimp		-GP = Guide Post Holes	Tape & Reel is standard. Leave blank for Tape & Reel. -FR = Full Reel Tape & Reel (must order max. quantity per reel; contact Samtec for quantity breaks)

NO. OF ROWS	A	B
-04	(12.48) .491	(7.46) .294
-08	(16.48) .649	(11.46) .451
-10	(18.48) .728	(13.46) .530

NO. PINS PER ROW	C	D
-20	(29.62) 1.166	(24.12) .950
-30	(37.62) 1.481	(32.12) 1.265
-40	(45.62) 1.796	(40.12) 1.580
-50	(53.62) 2.111	(48.12) 1.894

View complete specifications at: samtec.com?SEAF8-RA

Notes:
Some sizes, styles and options are non-standard, non-returnable

LPARRAY™

LOW PROFILE OPEN-PIN-FIELD ARRAYS

(1.27 mm) .050" PITCH

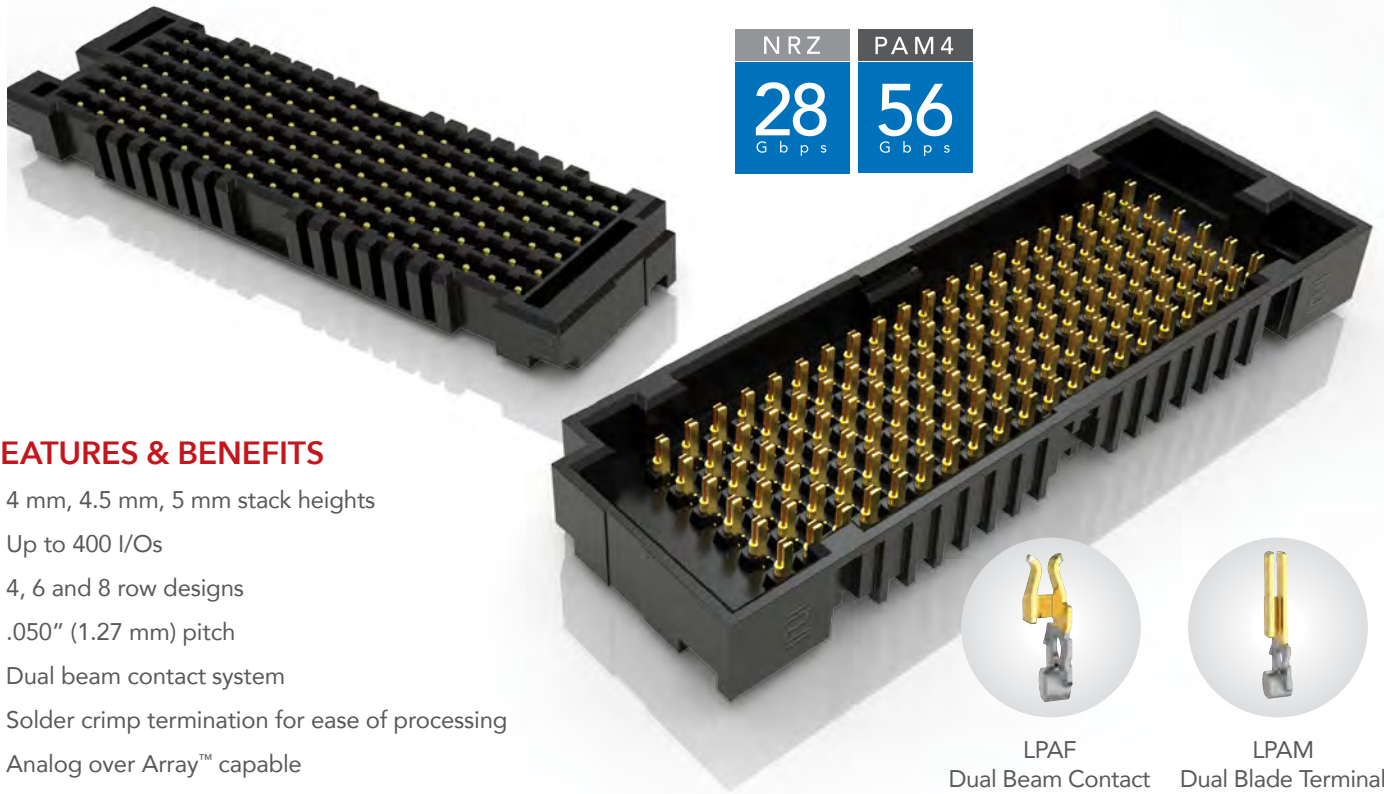

FEATURES & BENEFITS

- 4 mm, 4.5 mm, 5 mm stack heights
- Up to 400 I/Os
- 4, 6 and 8 row designs
- .050" (1.27 mm) pitch
- Dual beam contact system
- Solder crimp termination for ease of processing
- Analog over Array™ capable
- Board stacking standoffs available to assist with unmating and reduce risk for component damage on board

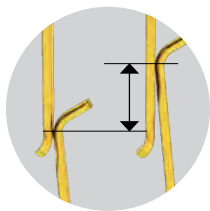

(0.51 mm) .020"
Nominal Wipe

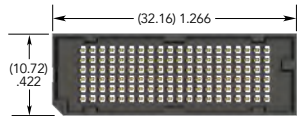

LPAM Series; 120 pins

MAXIMUM GROUNDING & ROUTING FLEXIBILITY

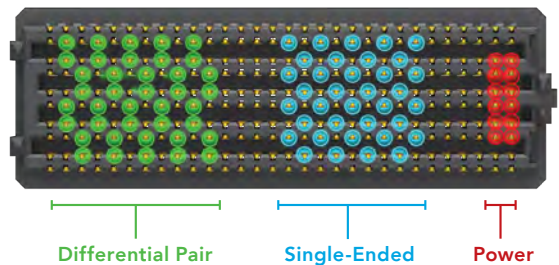

KEY SPECIFICATIONS (LPAM/LPAF)

PITCH	TOTAL PINS	INSULATOR MATERIAL	CONTACT MATERIAL	PLATING	CURRENT RATING	VOLTAGE RATING	LEAD-FREE SOLDERABLE
1.27 mm x 1.27 mm	Up to 400 I/Os	Black LCP	Copper Alloy	Au or Sn over 50 μ" (1.27 μm) Ni	2.2 A per pin (8 adjacent pins powered)	250 VAC/354 VDC	YES

(1.27 mm) .050" PITCH • LOW PROFILE OPEN-PIN-FIELD ARRAYS

SERIES	NO. PINS PER ROW	LEAD STYLE	PLATING OPTION	NO. OF ROWS	SOLDER TYPE	K	"X"R
LPAM Terminal	-10, -20, -30, -40,	-01.0 = (1.0 mm) .039" (LPAM only)	-L = 10 μ" (0.25 μm) Gold on contact area, Matte Tin on solder tail	-04 -06 -08	-1 = Tin/Lead Alloy Solder Crimp		-K = Polyimide film Pick & Place Pad
LPAF Socket	-50 (-08 rows only)	-01.5 = (1.5 mm) .060" (LPAM only)			-2 = Lead-Free Solder Crimp		-TR = Tape & Reel
		-03.0 = (3.0 mm) .118" (LPAF only)					-FR = Full Reel Tape & Reel (must order max. quantity per reel; contact Samtec for quantity breaks)
		-03.5 = (3.5 mm) .138" (LPAF only)					

LPAM
Board Mates:
LPAF
Standoffs:
JSO, SO

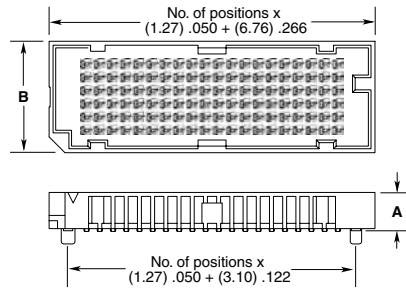
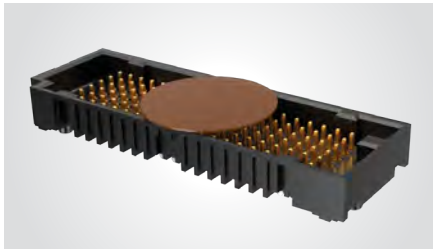

NO. OF ROWS	B
-04	(8.18) .322
-06	(10.72) .422
-08	(13.26) .522

LEAD STYLE	A
-01.0	(3.68) .145
-01.5	(4.19) .165

View complete specifications at: samtec.com?LPAM

LPAF
Board Mates:
LPAM
Standoffs:
JSO, SO

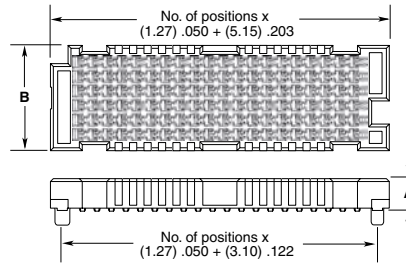
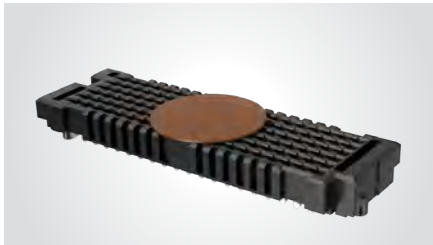

NO. OF ROWS	B
-04	(6.71) .264
-06	(9.25) .364
-08	(11.79) .464

LEAD STYLE	A
-03.0	(2.79) .110
-03.5	(3.30) .130

MATED HEIGHTS*		
LPAM LEAD STYLE	LPAF LEAD STYLE	
	-03.0	-03.5
-01.0	(4.00) .157	(4.50) .177
-01.5	(4.50) .177	(5.00) .197

*Processing conditions will affect mated height.

Notes:
Some sizes, styles and options are non-standard, non-returnable

View complete specifications at: samtec.com?LPAF

SUPERNOVA® LOW PROFILE COMPRESSION INTERPOSER

PAM4
56
Gbps

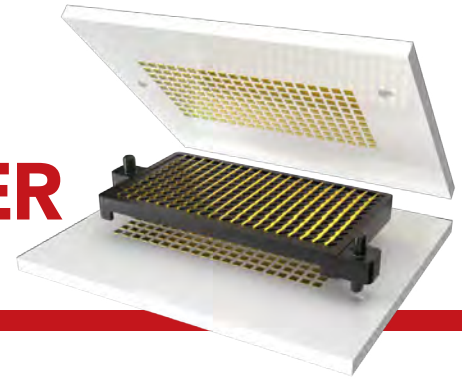

(1.00 mm) .0394" PITCH • GMI SERIES

SPECIFICATIONS

Insulator Material:
Black LCP
Contact Material:
Copper Alloy
Plating:
Au or 50 μ" (1.27 μm) Ni
Current Rating:
.9 A per pin
(10 pins powered)
Voltage Rating:
200 VAC/283 VDC

PROCESSING

Lead-Free Solderable:
Yes
SMT Lead Complanarity:
(0.05 mm) .002" (10-20)*
(0.08 mm) .003" (30)*
*(.004" stencil solution
may be available;
contact ipg@samtec.com)

GMI	POSITIONS PER ROW	STYLE	BOARD SPACING	PLATING OPTION	ROWS
	-10, -20, -30	-2 = Dual Compression	-1.27 = (1.27 mm) .050" Board Space	-G = 10 μ" (0.25 μm) Gold on contact area	-10 = Ten Rows



GMI Series is an ideal low-cost solution for board stacking, module-to-board or LGA interface

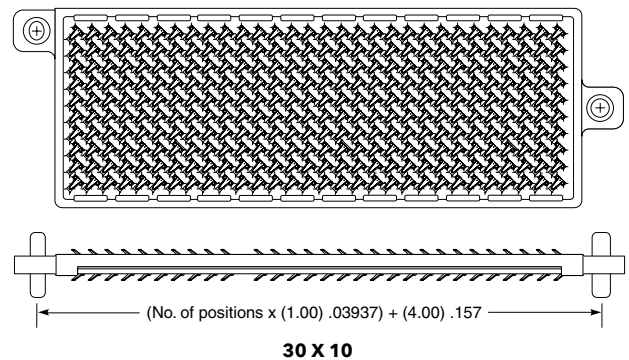
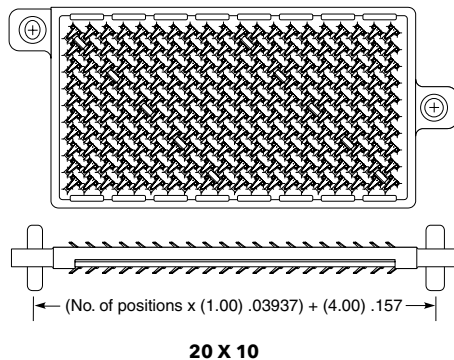
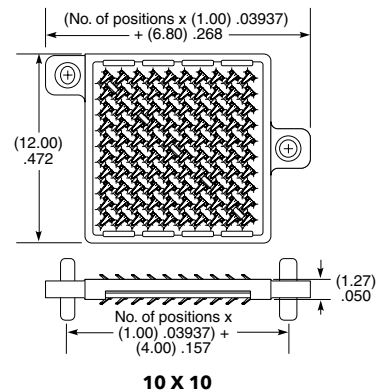

Note:
Some lengths, styles and options are non-standard, non-returnable

SI-FLY[®] HD

IN DEVELOPMENT: 224 Gbps PAM4 SOLUTIONS

BOARD-TO-BOARD AND BACKPLANE SYSTEMS



SI-FLY[®] HD HIGH-DENSITY MEZZANINE ARRAYS

- High-density with up to 64 differential pairs per square inch
- Mezzanine arrays route an extremely high number of transmission lines from one PCB to the next
- PCIe[®] 7.0 capable
- Surface mount reflow technology to the PCB
- Operating temperatures supporting -55 °C to +125 °C
- Series: SFBF, SFBM
- Visit samtec.com/sifly-hd

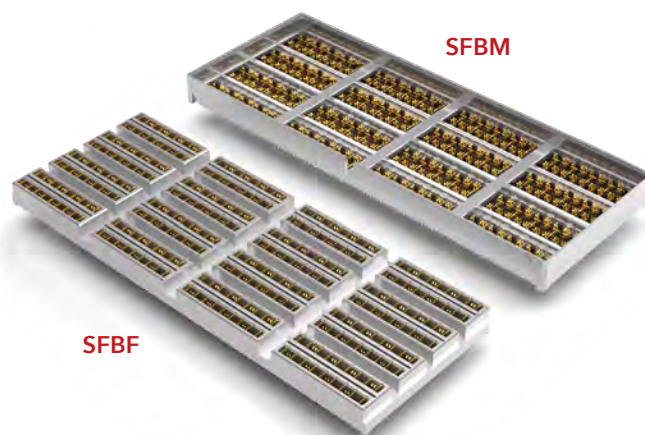

SI-FLY[®] HD HIGH-DENSITY BACKPLANE SYSTEM

- Cable-to-board and cable-to-cable for design flexibility and extended reach
- Up to 64 differential pairs; 8 pairs per row
- Eye Speed[®] hyper low skew twinax cable with 1.75 ps/m max intra-pair skew
- Series: SBCM/SBTM, SBCF
- Contact HSBP@samtec.com for more information

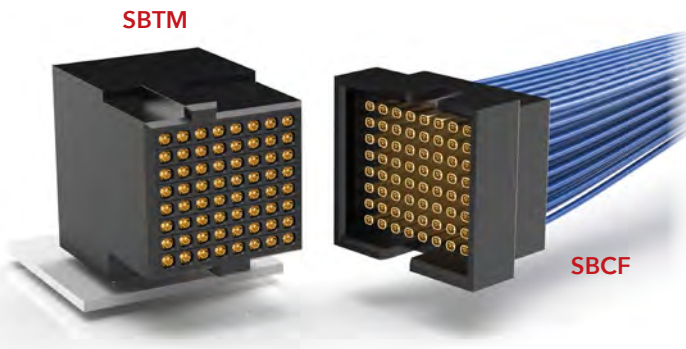

NEXT GEN 224 Gbps PAM4 SOLUTIONS

Samtec next gen interconnect solutions are designed with the flexibility and performance to meet the challenges of 224 Gbps PAM4 architectures. Visit samtec.com/224 for more information.

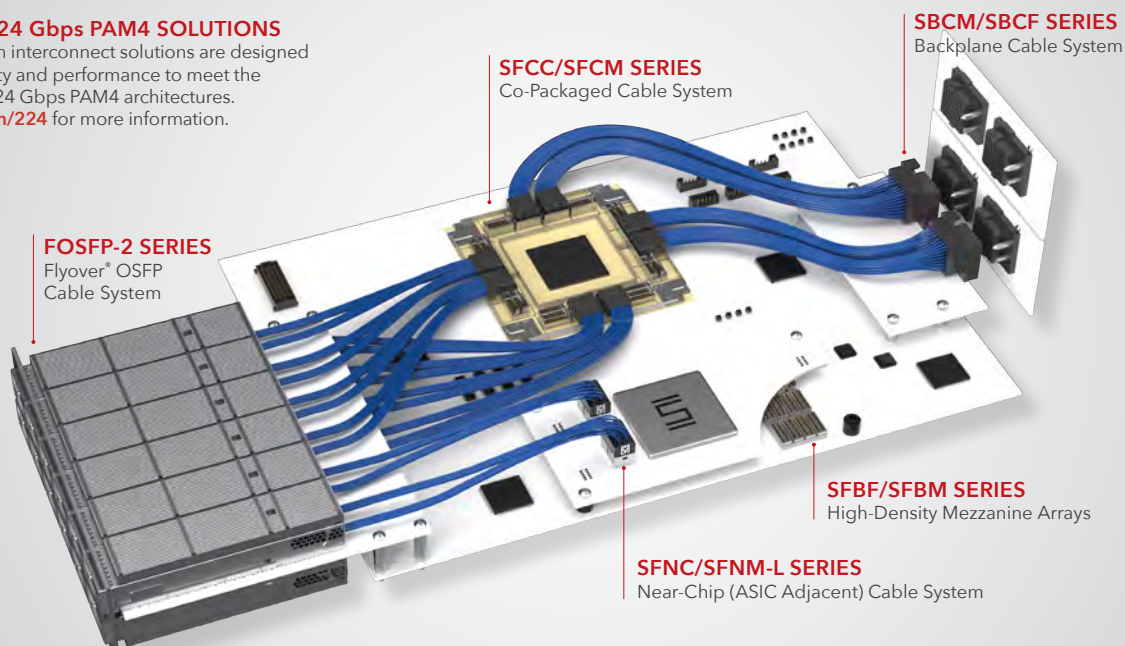

BOARD-TO-BOARD GUIDE POST STANDOFF



GPISO/GPSOM SERIES

GPISO
Use With:
NVAX, APX6, ADX6,
UMPX, UDX6

SERIES	BOARD STACK HEIGHT	LEAD STYLE	MATERIAL	KIT OPTION
GPISO GPSOM	Specify BOARD STACK HEIGHT from chart	-01 = Press-In (GPISO only) = Press-In with Nut (GPSOM only) -02 = Press-In with Nut (GPISO only)	-01 = 303 Stainless Steel with MIL-C-13924 black oxide finish	Leave blank for kit -N = No hardware (Standoff only)

SPECIFICATIONS

Locking Compound:
Nylon

BOARD STACK HEIGHT	A	B	C
-0400	(4.00) .157	(3.15) .124	(3.65) .144
-0500	(5.00) .197	(4.15) .163	(4.65) .183
-0515	(5.15) .203	(4.30) .169	(4.80) .189
-0700	(7.00) .276	(6.15) .242	(6.65) .262
-0715	(7.15) .281	(6.30) .248	(6.80) .268
-0865	(8.65) .341	(7.80) .307	(8.30) .327
-0900	(9.00) .354	(8.15) .321	(8.65) .341
-0915	(9.15) .360	(8.30) .327	(8.80) .346
-1000	(10.00) .394	(9.15) .360	(9.65) .380
-1015	(10.15) .400	(9.30) .366	(9.80) .386
-1115	(11.15) .439	(10.30) .406	(10.80) .425
-1200	(12.00) .472	(11.15) .439	(11.65) .459
-1215	(12.15) .478	(11.30) .445	(11.80) .465
-1315	(13.15) .518	(12.30) .484	(12.80) .504
-1415	(14.15) .557	(13.30) .524	(13.80) .543
-1515	(15.15) .596	(14.30) .563	(14.80) .583
-1524	(15.24) .600	(14.39) .567	(14.89) .586
-1615	(16.15) .636	(15.30) .602	(15.80) .622

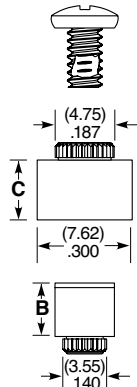

-01 LEAD STYLE

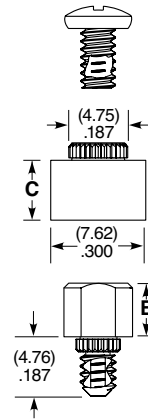
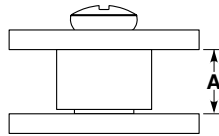

-02 LEAD STYLE

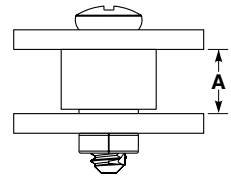

APPLICATION

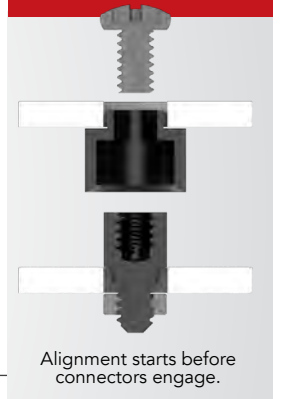

Notes:
Standoffs to be used with (1.57 mm) .062" min thick boards. Threaded options PCB max thickness of (3.16 mm) .124".

Some sizes, styles and options are non-standard, non-returnable.

Components are to be packaged in separate bags unassembled. Top and bottom components available for purchase separately, contact Samtec.

GPSOM
Use With:
NVAX, ADX6, UMPX,
SEAX, ERX8

SPECIFICATIONS

Material:
Stainless Steel with black oxide finished

Notes:
Standoffs to be used with (1.57 mm) .062" min thick boards. Threaded options PCB max thickness of (3.16 mm) .124".

Some sizes, styles and options are non-standard, non-returnable.

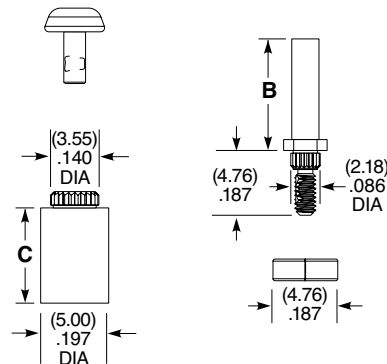

GPSOM-XXXX-01-01 SHOWN

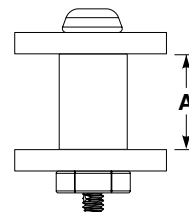

BOARD STACK HEIGHT	A	B	C
-0700	(7.00) .276	(8.20) .323	(7.00) .276
-0900	(9.00) .354	(10.20) .402	(9.00) .354

Components are to be packaged in separate bags unassembled. Top and bottom components available for purchase separately, contact Samtec.

JACK SCREW STANDOFF



JSO SERIES

JSO
Use With:
SEAX, SEAX8, LPAX, LSHM

JSO

**BOARD
STACKER**

LEAD STYLE

**PLATING
OPTION**

SPECIFICATIONS

Material:
Stainless Steel
Locking Compound:
Nylon

Specify
BOARD STACKER
from chart

-01
= Press-In
(-0415, -0515, -0715, -0815 only)

-03
= Male Thread
(-0815, -1015, -1115, -1615 only)

-L
= Locking compound
(Not available with -01 lead style,
Required for -03 lead style)

BOARD STACKER	A	B	BOARD STACK HEIGHT
-0415	(4.15) .163	(2.50) .098	4 mm
-0515	(5.15) .203	(3.50) .138	5 mm
-0715	(7.15) .281	(5.50) .217	7 mm
-0815	(8.15) .321	(6.50) .256	8 mm
-1015	(10.15) .400	(8.50) .335	10 mm
-1115	(11.15) .439	(9.50) .374	11 mm
-1615	(16.15) .636	(14.50) .571	16 mm

ALSO AVAILABLE
Contact Samtec

Other heights
Locking compound removed

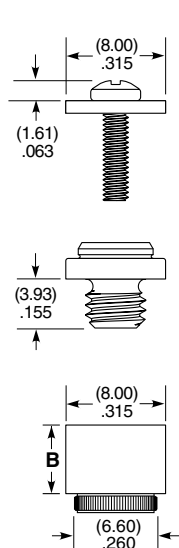

-01 LEAD STYLE

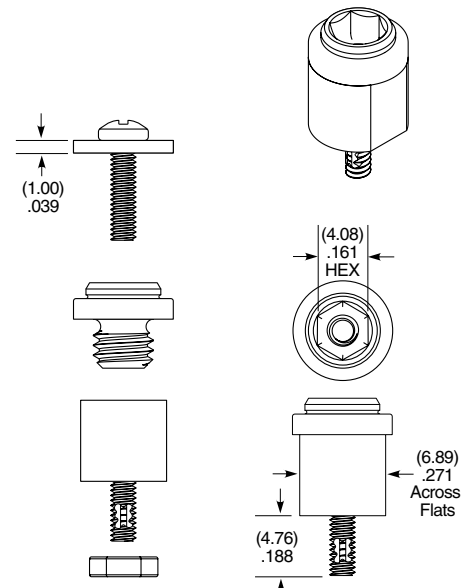
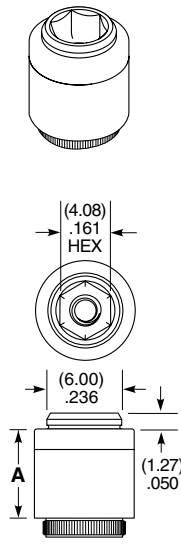

-03 LEAD STYLE

Note:
Some sizes, styles and
options are non-standard,
non-returnable.

Components are to be packaged in separate bags unassembled.

APPLICATION

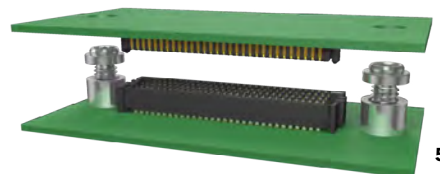
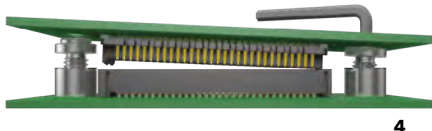
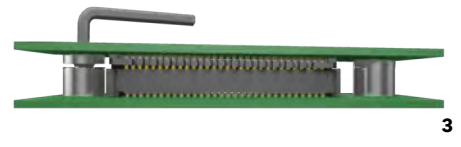
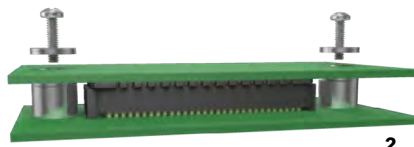
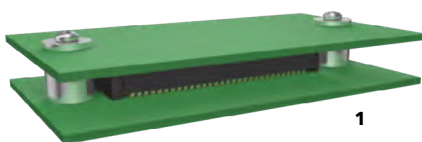

PRECISION BOARD STACKING STANDOFF

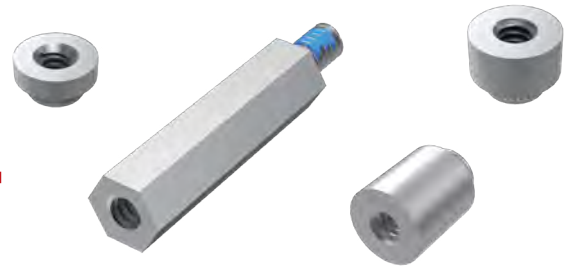

SO SERIES

SO Use With:
QXH, QXE, QXS,
QXSS, QRX8, ERX5,
ERX6, ERX8, LSHM,
LSS, LSEM, SX4, SX5, XLH

SPECIFICATIONS

Material: Aluminum
Locking Compound: Nylon



Specify BOARD STACKER from chart

-01
= Female Thread/Press-In (-0515 thru -0865 only)

-02
= Male/Male Thread (-0515 and -1115 thru -2515 only)

-03
= Male/Female Thread (-0815 thru -2515 only)

-05
= Female/Female Thread (-0515 thru -2515 only)

-01
= #4-40 Thread

-02
= M3 x 0.5 Thread°

-L
= -02 & -03 Lead Style thread locking compound (Leave blank for -01 Lead Style)

INDUSTRY STANDARD SOLUTIONS

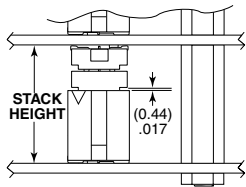

Requires Standoff
SO-1524-03-01-01-L or
JSOM-1524-02 for 15.24 mm
or SO-2200-03-01-01-L
for 22 mm board spacing.
Connectors designed to not
fully seat when mated.
For more information on the JSOM,
visit samtec.com?JSOM

BOARD STACKER	A	BOARD STACK HEIGHT
-0515	(5.15) .203	5 mm
-0715	(7.15) .282	7 mm
-0815	(8.15) .321	8 mm
-0865	(8.65) .341	8.5 mm
-1115	(11.15) .439	11 mm
-1215	(12.15) .478	12 mm
-1524	(15.24) .600	15.09 mm
-1615	(16.15) .636	16 mm
-1890	(18.90) .744	18.75 mm
-1915	(19.15) .754	19 mm
-2515	(25.15) .990	25 mm

INDUSTRY STANDARD	INTERCONNECTS			
	TERMINAL	SOCKET	BANKS	STACK HEIGHT
SUMIT™	ASP-129637-01	ASP-129646-01	1	15.24 mm
PCI/104-Express™	ASP-129637-03	ASP-129646-03	3	15.24 mm
PCI/104-Express™	ASP-129637-13	ASP-129646-22	1	15.24 mm
PCI/104-Express™	ASP-142781-01	ASP-129646-01	1	22 mm
PCI/104-Express™	ASP-142781-02	ASP-129646-02	2	22 mm
PCI/104-Express™	ASP-142781-03	ASP-129646-03	3	22 mm

ALSO AVAILABLE

Contact Samtec

Other heights
Stainless Steel
Locking compound removed
Other materials and threading
No Hardware

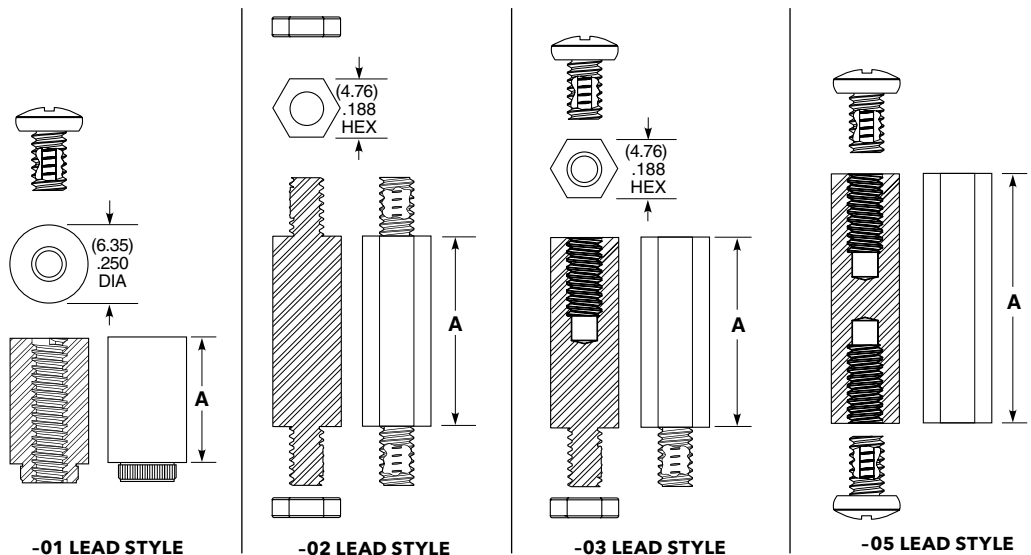

Note:
Some sizes, styles and options are non-standard, non-returnable.

Components are to be packaged in separate bags unassembled.

HIGH-SPEED DUAL ROW SYSTEMS

25+ Gbps PERFORMANCE • INTEGRAL GROUND PLANE • EDGE RATE® CONTACTS

39-40

Q STRIP® INTEGRAL GROUND PLANE INTERCONNECTS

0.50 mm (.0197") Pitch (QTH, QSH)
0.80 mm (.0315") Pitch (QTE, QSE)
0.635 mm (.025") Pitch (QTS, QSS)



42-43

Q2™ RUGGED INTEGRAL GROUND PLANE INTERCONNECTS

0.635 mm (.025") Pitch (QMS, QFS)
0.635 mm (.025") Pitch Shielded (QMSS, QFSS)

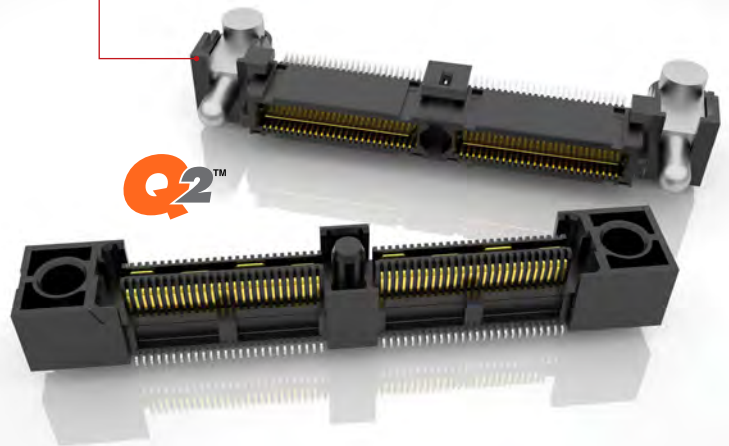

44

Q RATE® SLIM BODY INTEGRAL GROUND PLANE INTERCONNECTS

0.80 mm (.0315") Pitch (QRM8, QRF8)



49-54

EDGE RATE® RUGGED HIGH-SPEED INTERCONNECTS

0.50 mm (.0197") Pitch (ERM5, ERF5)
0.635 mm (.025") Pitch (ERM6, ERF6)
0.80 mm (.0315") Pitch (ERM8, ERF8)

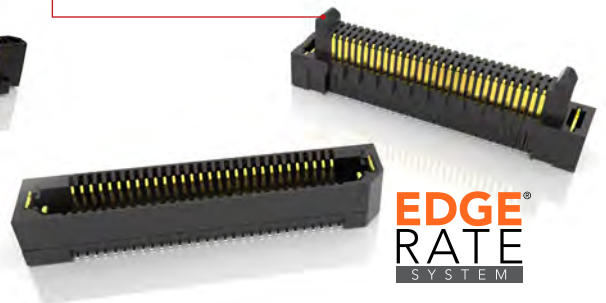



HIGH-SPEED GROUND PLANE DUAL ROW CONNECTORS

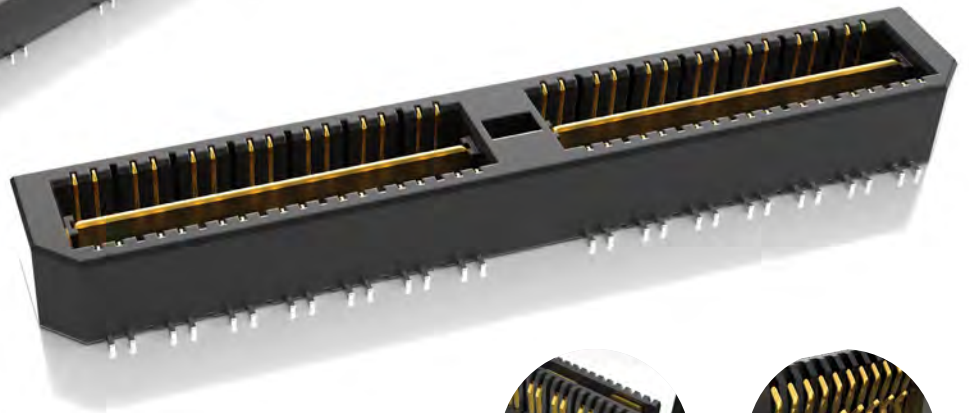
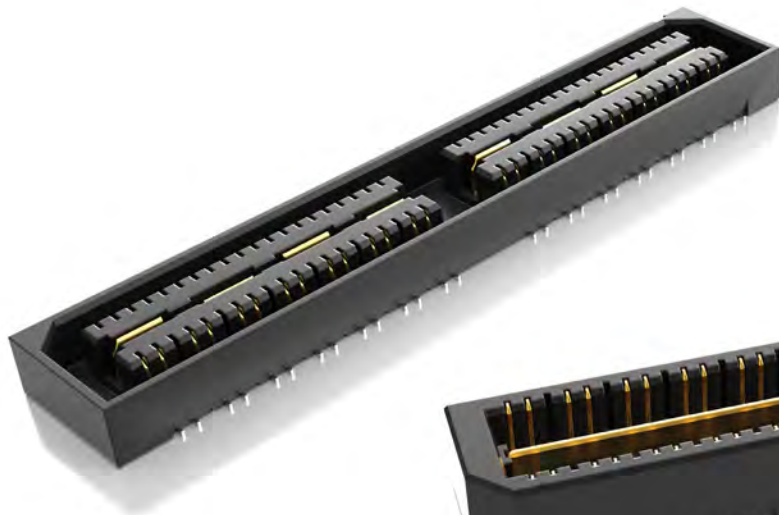

FEATURES & BENEFITS

- Designed for high-speed board-to-board applications where signal integrity is essential
- Q Strip® low profile connectors on 0.50 mm, 0.635 mm and 0.80 mm pitches
- Q Rate® slim connectors with Edge Rate® contacts on 0.80 mm pitch with a 1.20 mm contact wipe
- Q2™ rugged connectors on 0.635 mm pitch with increased insertion depth for rugged applications
- Right-angle, edge mount, EMI shielding and power options
- Differential pair and single-ended routing



Differential Pairs
Reduce Noise



Rugged Edge Rate®
Contact System



Power, Retention
& RF Options



Precision Board
Stacking Standoffs

INTEGRAL GROUND / POWER PLANE

- Surface mount ground plane between two signal rows improves electrical performance
- Significantly reduces row-to-row crosstalk
- Integral metal plane for power to 25 Amps



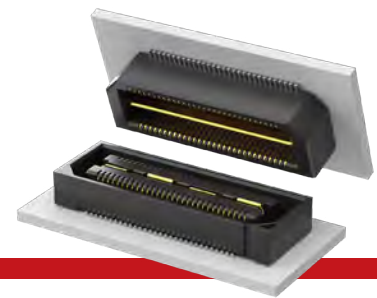

(0.50 mm) .0197" PITCH • QTH/QSH SERIES

QTH
Board Mates:
QSH

QSH
Board Mates:
QTH

QTH/QSH
Cable Mates:
HQCD, HQDP

Standoffs:
SO

QTH	PINS PER ROW NO. OF PAIRS	LEAD STYLE	PLATING OPTION	TYPE	A	OTHER OPTIONS	"X"R
	-030, -060, -090 (60 total pins per bank = -D)	Specify LEAD STYLE from chart	-F = Gold flash on contact, Matte Tin on tail	-D = Single-Ended		-K = (7.00 mm) .275" DIA Polyimide film Pick & Place Pad (Not available with -05 & -07 lead style)	Leave blank for Tray Packaging
	-020, -040, -060 (20 pairs per bank = -D-DP)		-L = 10 μ" (0.25 μm) Gold on contact, Matte Tin on tail	-D-DP = Differential Pair (-01 only)		-L = Latching Option (-01 lead style only) (Not available on -060 (-D-DP) & -090)	-TR =Tape & Reel (Not available with -05 & -07 lead style)
			-C = 50 μ" (1.27 μm) Electro-Polished Selective Gold on contact, Matte Tin on tail (passes 10 year MFG testing)				-FR = Full Reel Tape & Reel (must order max. quantity per reel; contact Samtec for quantity breaks) (Not available with -05 & -07 lead style)

SPECIFICATIONS

Insulator Material:
Liquid Crystal Polymer
Contact Material:
Phosphor Bronze
Plating:
Au or Sn over 50 μ" (1.27 μm) Ni
Operating Temp Range:
-55 °C to +125 °C
Current Rating:
Contact:
2 A per pin (2 pins powered)
Ground Plane:
25 A per ground plane (1 ground plane powered)
Voltage Rating:
175 VAC/247 VDC
Max Cycles:
100

QTH LEAD STYLE	A	HEIGHT WITH QSH*
-01	(4.27) .168	(5.00) .197
-02	(7.26) .286	(8.00) .315
-03	(10.27) .404	(11.00) .433
-04	(15.25) .600	(16.00) .630
-05	(18.26) .718	(19.00) .748
-07	(24.24) .954	(25.00) .984
-09	(13.26) .522	(14.00) .551

*Processing conditions will affect mated height. See SO Series for board space tolerances.

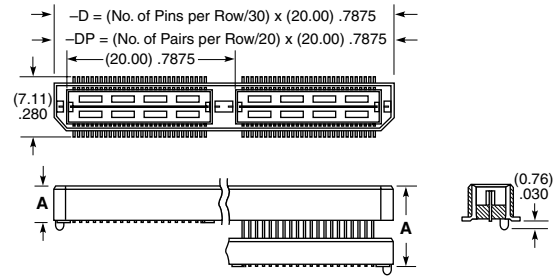

PROCESSING

Lead-Free Solderable:
Yes
SMT Lead Coplanarity:
(0.10 mm) .004" max (030-060)
(0.15 mm) .006" max (090)*
*(.004" stencil solution may be available; contact ipg@samtec.com)
Board Stacking:
For applications requiring more than two connectors contact ipg@samtec.com

STANDARDS

PISMO™ 1:
Visit samtec.com/standards for more information.



QSH	PINS PER ROW NO. OF PAIRS	01	PLATING OPTION	TYPE	A	OTHER OPTIONS	"X"R
	-030, -060, -090 (60 total pins per bank = -D)		-F = Gold flash on contact, Matte Tin on tail	-D = Single-Ended		-K = (8.25 mm) .325" DIA Polyimide film Pick & Place Pad	Leave blank for Tray Packaging
	-020, -040, -060 (20 pairs per bank = -D-DP)		-L = 10 μ" (0.25 μm) Gold on contact, Matte Tin on tail	-D-DP = Differential Pair		-L = Latching Option (Not available on -060 (-D-DP) & -090)	-TR =Tape & Reel (N/A -05 to -07 lead style)
			-C = 50 μ" (1.27 μm) Electro-Polished Selective Gold on contact, Matte Tin on tail (passes 10 year MFG testing)				-FR = Full Reel Tape & Reel (must order max. quantity per reel; contact Samtec for quantity breaks)

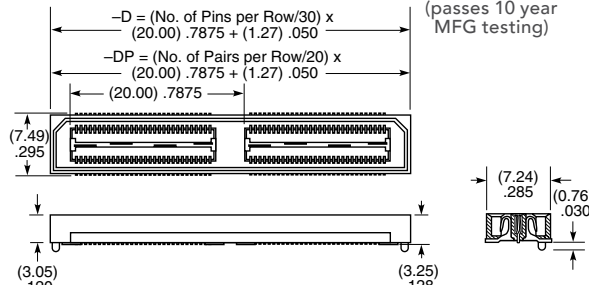

Note:
Some lengths, styles and options are non-standard, non-returnable.

View complete specifications at: samtec.com?QSH

See pg 46-47 for Right-Angle & Edge Mount options.



(0.80 mm) .0315" PITCH • QTE/QSE SERIES

QTE
Board Mates:
QSE

QSE
Board Mates:
QTE

QTE/QSE
Cable Mates:
EQCD, EQDP

Standoffs:
SO

QTE	PINS PER ROW NO. OF PAIRS	LEAD STYLE	PLATING OPTION	TYPE	A	OTHER OPTIONS	"X"R
	-020, -040, -060 (40 total pins per bank = -D)	Specify LEAD STYLE from Chart	-F = Gold flash on contact, Matte Tin on tail -L = 10 μ" (0.25 μm) Gold on contact, Matte Tin on tail -C = 50 μ" (1.27 μm) Electro-Polished Selective Gold on contact, Matte Tin on tail (passes 10 year MFG testing)	-D = Single-Ended -D-DP = Differential Pair (-01 only)		-K = (7.00 mm) .275" DIA Polyimide film Pick & Place Pad -L = Latching Option (N/A on -042 & -060 positions)	Leave blank for Tray Packaging -TR =Tape & Reel (Not available with -05 & -07 lead style) -FR = Full Reel Tape & Reel (must order max. quantity per reel; contact Samtec for quantity breaks) (Not available with -05 & -07 lead style)

SPECIFICATIONS

Insulator Material: Liquid Crystal Polymer
Contact Material: Phosphor Bronze
Plating: Au or Sn over 50 μ" (1.27 μm) Ni
Operating Temp Range: -55 °C to +125 °C
Current Rating: Contact: 2 A per pin (2 pins powered) Ground Plane: 23 A per ground plane (1 ground plane powered)
Voltage Rating: 225 VAC/318 VDC
Max Cycles: 100

QTE LEAD STYLE	A	HEIGHT WITH QSE*
-01	(4.27) .168	(5.00) .197
-02	(7.26) .286	(8.00) .315
-03	(10.27) .404	(11.00) .433
-04	(15.25) .600	(16.00) .630
-05	(18.26) .718	(19.00) .748
-07	(24.24) .954	(25.00) .984
-09	(13.26) .522	(14.00) .551

*Processing conditions will affect mated height. See SO Series for board space tolerances.

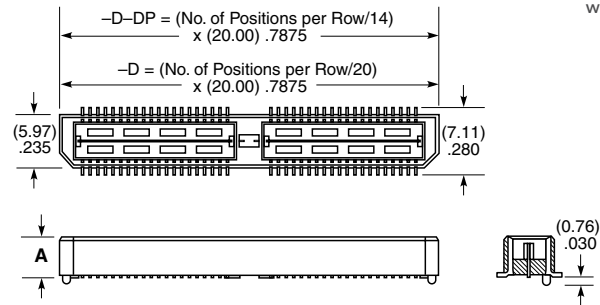

PROCESSING

Lead-Free Solderable: Yes
SMT Lead Coplanarity: (0.10 mm) .004" max (020-060)
Board Stacking: For applications requiring more than two connectors contact ipg@samtec.com

View complete specifications at: samtec.com?QTE



QSE	PINS PER ROW NO. OF PAIRS	01	PLATING OPTION	TYPE	A	OTHER OPTIONS	"X"R
	-020, -040, -060 (40 total pins per bank = -D)		-F = Gold flash on contact, Matte Tin on tail -L = 10 μ" (0.25 μm) Gold on contact, Matte Tin on tail -C = 50 μ" (1.27 μm) Electro-Polished Selective Gold on contact, Matte Tin on tail (passes 10 year MFG testing)	-D = Single-Ended -D-DP = Differential Pair		-GP = Guide Post -K = (8.25 mm) .325" DIA Polyimide Film Pick & Place Pad -L = Latching Option (Not available on -042 & -060 positions)	Leave blank for Tray Packaging -TR =Tape & Reel (40 positions max. with -GP) -FR = Full Reel Tape & Reel (must order max. quantity per reel; contact Samtec for quantity breaks) (40 positions max. with -GP)

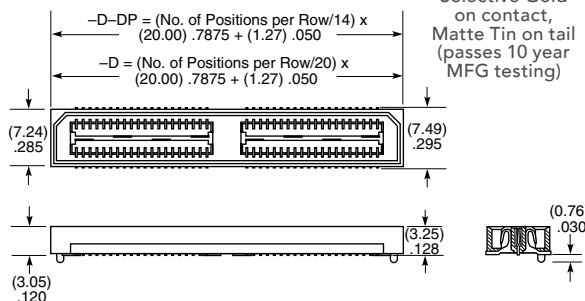

Note: Some lengths, styles and options are non-standard, non-returnable.

View complete specifications at: samtec.com?QSE



(0.635 mm) .025" PITCH • QTS/QSS SERIES

NRZ
25
Gbps



QTS
Board Mates:
QSS

QSS
Board Mates:
QTS

QTS/QSS
Cable Mates:
SQCD

Standoffs:
SO



QTS	NO. OF POSITIONS PER ROW -025, -050, -075 (50 total positions per bank)	LEAD STYLE Specify LEAD STYLE from Chart	PLATING OPTION -F = Gold flash on contact, Matte Tin on tail -L = 10 μ" (0.25 μm) Gold on contact, Matte Tin on tail -C = 50 μ" (1.27 μm) Electro-Polished Selective Gold on contact, Matte Tin on tail (passes 10 year MFG testing)	D	A	OTHER OPTIONS -K = (7.00 mm) .275" DIA Polyimide film Pick & Place Pad	"X"R Leave blank for Tray Packaging -TR = Tape & Reel -FR = Full Reel Tape & Reel must order max. quantity per reel; contact Samtec for quantity breaks)
------------	--	--	--	----------	----------	--	--

SPECIFICATIONS

Insulator Material: Liquid Crystal Polymer
Contact Material: Phosphor Bronze
Plating: Au or Sn over 50 μ" (1.27 μm) Ni
Operating Temp Range: -55 °C to +125 °C
Current Rating: Contact: 1.3 A per pin (2 pins powered) Ground Plane: 23.1 A per ground plane (1 ground plane powered)
Voltage Rating: 275 VAC/389 VDC
Max Cycles: 100

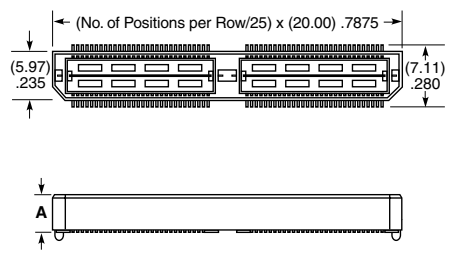

QTS LEAD STYLE	A	MATED HEIGHT WITH QSS
-01	(4.27) .168	(5.00) .197
-02	(7.26) .286	(8.00) .315

*Processing conditions will affect mated height. See SO Series for board space tolerances.

View complete specifications at: samtec.com?QTS

PROCESSING

Lead-Free Solderable: Yes
QTS SMT Lead Coplanarity: (0.10 mm) .004" max (025-075)
QSS SMT Lead Coplanarity: (0.10 mm) .004" max (025-050) (0.15 mm) .006" max (075)*
 *(.004" stencil solution may be available; contact ipg@samtec.com)
Board Stacking: For applications requiring more than two connectors contact ipg@samtec.com



QSS	NO. OF POSITIONS PER ROW -025, -050, -075 (50 total positions per bank)	01	PLATING OPTION -F = Gold flash on contact, Matte Tin on tail -L = 10 μ" (0.25 μm) Gold on contact, Matte Tin on tail -C = 50 μ" (1.27 μm) Electro-Polished Selective Gold on contact, Matte Tin on tail (passes 10 year MFG testing)	D	A	OTHER OPTIONS -GP = Guide Holes for mating with QTS-RA -K = (8.25 mm) .325" DIA Polyimide Film Pick & Place Pad	"X"R Leave blank for Tray Packaging -TR = Tape & Reel -FR = Full Reel Tape & Reel must order max. quantity per reel; contact Samtec for quantity breaks)
------------	--	-----------	--	----------	----------	--	--

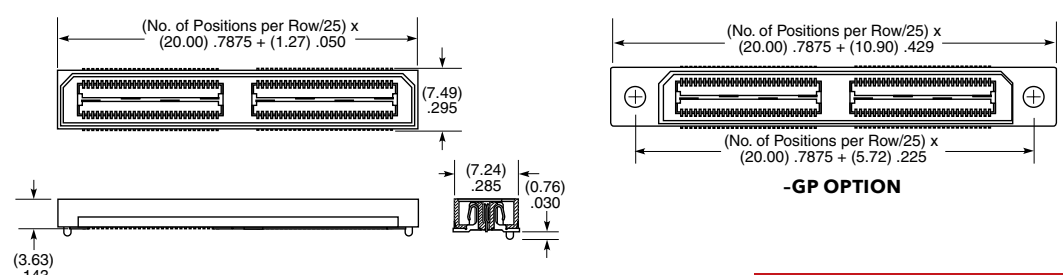

Note: Some lengths, styles and options are non-standard, non-returnable.

View complete specifications at: samtec.com?QSS

See pg 46-47 for Right-Angle & Edge Mount options.



NRZ
25
Gbps

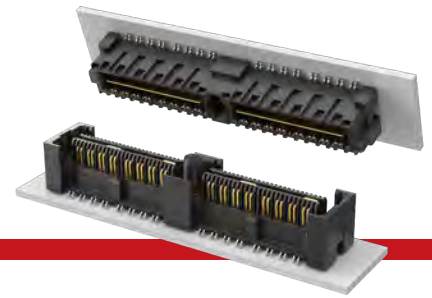

(0.635 mm) .025" PITCH • QMS/QFS SERIES

QMS
Board Mates:
QFS

QFS
Board Mates:
QMS

QMS/QFS
Cable Mates:
6QCD

Standoffs:
SO

QMS	PINS PER ROW NO. OF PAIRS	LEAD STYLE	PLATING OPTION	TYPE	A	OTHER OPTION
-----	---------------------------	------------	----------------	------	---	--------------

-026,
-052, -078
(52 total pins per bank = -D)

Specify LEAD STYLE from Chart

-L
= 10 μm (0.25 μm)
Gold on contact, Matte Tin on tail (-05.75 & -06.75 Lead Style Only)

-D
= Single-Ended
-D-DP
= Differential Pair

-K
= (5.50 mm) .217" DIA Polyimide film Pick & Place Pad

-016,
-032, -048
(16 pairs per bank = -D-DP)

-SL
= 10 μm (0.25 μm)
Gold on contact, Matte Tin on tail (-09.75 Lead Style Only)

(-078 & -048 Not available with -09.75 Lead Style)

PACKAGING OPTION

Tape & Reel Options (-TR & -FR) available. Visit series web page and view engineering prints for complete specifications.

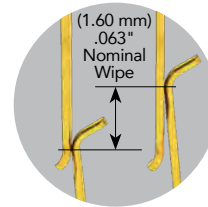

MATED HEIGHT*			
QMS LEAD STYLE	A	QFS LEAD STYLE	
		-4.25	-6.25
-05.75	(5.38) .212	10 mm	12 mm
-06.75	(6.35) .250	11 mm	13 mm
-09.75	(9.35) .368	14 mm	16 mm

*Processing conditions will affect mated height. See SO Series for board space tolerances.

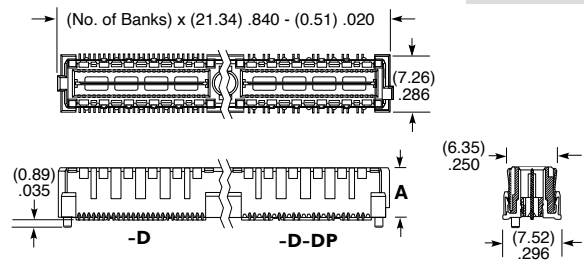

SPECIFICATIONS

Insulator Material: Liquid Crystal Polymer
Contact & Ground Plane Material: Phosphor Bronze
Plating: Au over 50 μm (1.27 μm) Ni (Tin on Ground Plane Tail)
Operating Temp Range: -55 °C to +125 °C
Current Rating: Contact: 2.6 A per pin (2 pins powered) Ground Plane: 15.7 A per ground plane (1 ground plane powered)
Voltage Rating: 250 VAC/ 354 VDC

PROCESSING

Lead-Free Solderable: Yes
QMS SMT Lead Coplanarity: (0.10 mm) .004" max (026-052) (0.15 mm) .006" max (078)* *(.004" stencil solution may be available; contact ipg@samtec.com)
QFS SMT Lead Coplanarity: (0.10 mm) .004" max (026-078)
Board Stacking: For applications requiring more than two connectors contact ipg@samtec.com

STANDARDS

SUMIT™
PCI/104-Express®
PCI/104-Express® OneBank
Visit samtec.com/standards for more information, including mated heights and complete part numbers.
PCI-SIG® PCI Express® and the PCIe® design marks are registered trademarks and/or service marks of PCI-SIG.

Note: Some lengths, styles and options are non-standard, non-returnable.

View complete specifications at: samtec.com?QMS

QFS	PINS PER ROW NO. OF PAIRS	LEAD STYLE	PLATING OPTION	TYPE	A	OTHER OPTION
-----	---------------------------	------------	----------------	------	---	--------------

-026, -052,
-078
(52 total pins per bank = -D)

Specify LEAD STYLE from Chart

-L
= 10 μm (0.25 μm)
Gold on contact, Matte Tin on tail (-04.25 Lead Style only)

-D
= Single-Ended
-D-DP
= Differential Pair (-04.25 Lead Style only)

-GP
= Guide Holes (-04.25 Lead Style only)

-016, -032,
-048
(16 pairs per bank = -D-DP)

-SL
= 10 μm (0.25 μm)
Gold on contact, Matte Tin on tail (-06.25 Lead Style only)

PACKAGING OPTION

Tape & Reel Options (-TR & -FR) available. Visit series web page and view engineering prints for complete specifications.

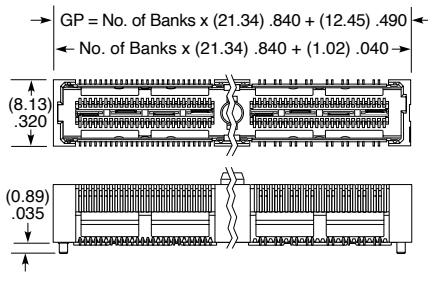

LEAD STYLE	A
-04.25	(7.44) .293
-06.25	(9.42) .371

View complete specifications at: samtec.com?QFS

See pg 46-47 for Right-Angle & Edge Mount options.



(0.635 mm) .025" PITCH • QMSS/QFSS SERIES

NRZ
14
Gbps

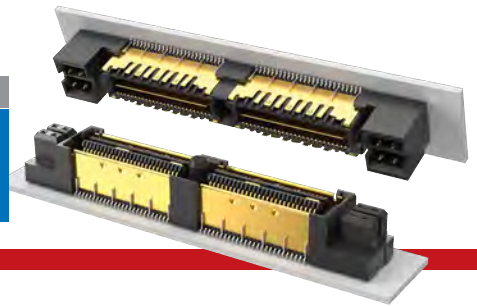

QMSS
Board Mates:
QFSS

QFSS
Board Mates:
QMSS

QMSS/QFSS
Standoffs:
SO

QMSS	PINS PER ROW NO. OF PAIRS	06.75	PLATING OPTION	TYPE	A	OTHER OPTION
------	---------------------------	-------	----------------	------	---	--------------

-026, -052, -078
(52 total pins per bank / 40 signals + 12 grounds to shield = -D)

-016, -032, -048
(16 pairs per bank = -D-DP)

-L
= 10 μm (0.25 μm)
Gold on contact,
Matte Tin on tail

-D
= Single-Ended

-D-DP
= Differential Pair

-K
= (5.50 mm) .217" DIA
Polyimide film Pick & Place Pad (N/A with -PC4)

-PC4
= 4 Power Pins/End (N/A with -A)

SPECIFICATIONS

Insulator Material:
Liquid Crystal Polymer
Terminal, Ground Plane & Shield Material:
Phosphor Bronze
Plating:
Au over 50 μm (1.27 μm) Ni (Tin on Ground Plane Tail)
Operating Temp Range:
-55 °C to +125 °C
Current Rating:
Contact:
3.4 per pin (4 adjacent pins powered)
Ground Plane:
7.8 A per ground plane (2 ground planes powered)
Voltage Rating:
300 VAC/424 VDC

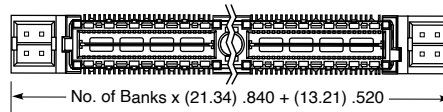
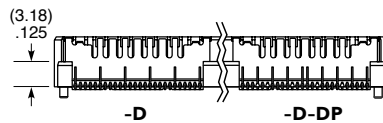
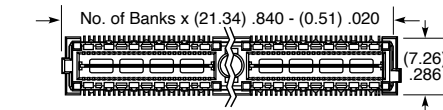

-PC4 OPTION

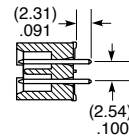
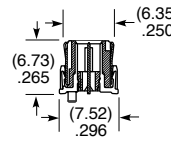

PACKAGING OPTION
Tape & Reel Options (-TR & -FR) available. Visit series web page and view engineering prints for complete specifications.

PROCESSING

Lead-Free Solderable:
Yes
SMT Lead Coplanarity:
(0.10 mm) .004" max (026-078)
Board Stacking:
For applications requiring more than two connectors contact ipg@samtec.com

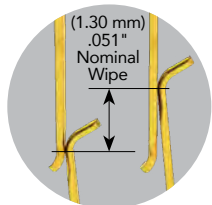

View complete specifications at: samtec.com?QMSS

QFSS	PINS PER ROW NO. OF PAIRS	04.25	PLATING OPTION	TYPE	A	OTHER OPTION
------	---------------------------	-------	----------------	------	---	--------------

-026, -052, -078
(52 total pins per bank / 40 signals + 12 grounds to shield = -D)

-016, -032, -048
(16 pairs per bank = -D-DP)

-L
= 10 μm (0.25 μm)
Gold on contact,
Matte Tin on tail

-D
= Single-Ended

-D-DP
= Differential Pair

-PC4
= 4 Power Pins/End (N/A with -A)

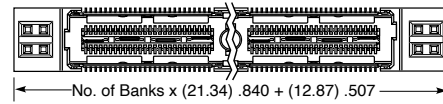
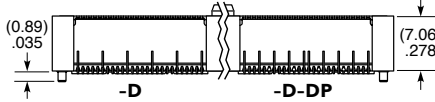
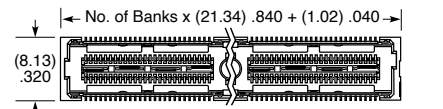

-PC4 OPTION

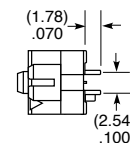
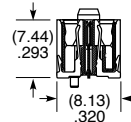

PACKAGING OPTION
Tape & Reel Options (-TR & -FR) available. Visit series web page and view engineering prints for complete specifications.

Note:
Some lengths, styles and options are non-standard, non-returnable.

View complete specifications at: samtec.com?QFSS



(0.80 mm) .0315" PITCH • QRM8/QRF8 SERIES

QRM8
Board Mates:
QRF8

QRF8
Board Mates:
QRM8

QRM8/QRF8
Cable Mates:
EQRD

SPECIFICATIONS

- Insulator Material:** Black LCP
- QRM8 Terminal Material:** Phosphor Bronze
- QRF8 Contact Material:** BeCu
- Ground Plane Material:** Phosphor Bronze
- Plating:** Au or Sn over 50 μ" (1.27 μm) Ni
- Operating Temp Range:** -55 °C to +125 °C
- Current Rating:** Contact: 3.3 A per pin (2 pins powered)
- Voltage Rating:** 215 VAC/304 VDC
- Max Cycles:** 100

PROCESSING

- Lead-Free Solderable:** Yes
- SMT Lead Coplanarity:** (0.10 mm) .004" max (018-026) (0.15 mm) .006" max (036-078)*
- *(.004" stencil solution may be available; contact ipg@samtec.com)
- Board Stacking:** For applications requiring more than two connectors contact ipg@samtec.com

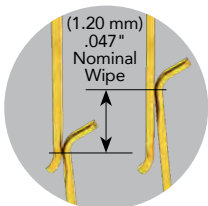

Note: Some lengths, styles and options are non-standard, non-returnable.

QRM8	PINS PER ROW NO. OF PAIRS	LEAD STYLE	PLATING OPTION	TYPE	A	OTHER OPTIONS	"X"R
	-026, -052, -078 (52 total pins per bank = -D)	-02.0 = 2 mm Body Height Not available with -054 & -078 Positions)	-L = 10 μ" (0.25 μm) Gold on contact, Matte Tin on tail	-D = Single-Ended -D-DP = Differential Pair		-GP = Guide Post -K = (5.00 mm) .197" DIA Polyimide Film Pick & Place Pad	Leave blank for Tray Packaging -TR = Tape & Reel -FR = Full Reel Tape & Reel (must order maximum quantity per reel; contact Samtec for quantity breaks)
	-018, -036, -054 (18 pairs per bank = -D-DP)	-05.0 = 5 mm Body Height -07.0 = 7 mm Body Height					

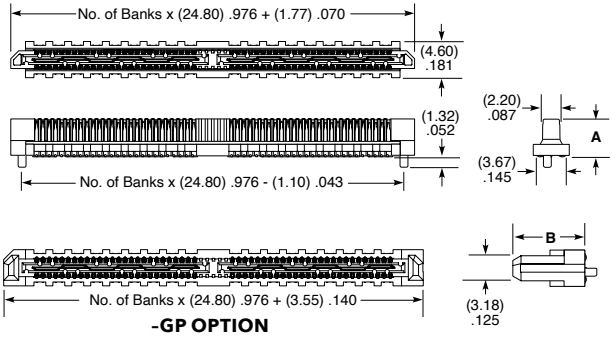

LEAD STYLE	A	B
-02	(4.81) .189	(6.12) .241
-05	(7.81) .307	(9.12) .359
-07	(9.78) .385	(11.12) .438

View complete specifications at: samtec.com?QRM8

QRF8	PINS PER ROW NO. OF PAIRS	LEAD STYLE	PLATING OPTION	TYPE	A	OTHER OPTIONS	"X"R
	-026, -052, -078 (52 total pins per bank = -D)	-05.0 = 5 mm Body Height -07.0 = 7 mm Body Height	-L = 10 μ" (0.25 μm) Gold on contact, Matte Tin on tail	-D = Single-Ended -D-DP = Differential Pair		-GP = Guide Post -K = (5.00 mm) .197" DIA Polyimide Film Pick & Place Pad	Leave blank for Tray Packaging -TR = Tape & Reel (Not available with -054 & -078 positions) -FR = Full Reel Tape & Reel (must order max. quantity per reel; contact Samtec for quantity breaks) (Not available with -054 & -078 positions)
	-018, -036, -054 (18 pairs per bank = -D-DP)						

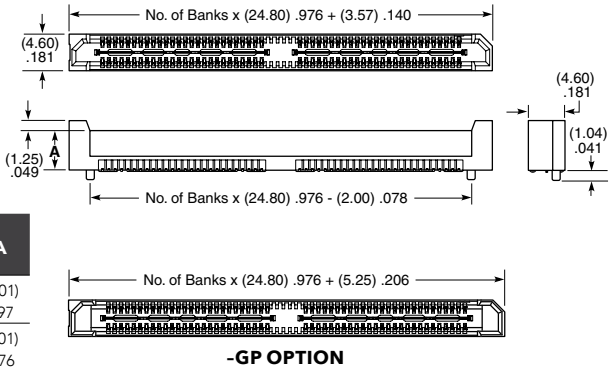

LEAD STYLE	A
-05	(5.01) .197
-07	(7.01) .276

MATED HEIGHT*			
QRF8 LEAD STYLE	QRM8 LEAD STYLE		
	-02.0	-05.0	-07.0
-05	(7.00) .276	(10.00) .394	(12.00) .472
-07	(9.00) .354	(12.00) .472	(14.00) .551

*Processing conditions will affect mated height. See SO Series for board space tolerances.

View complete specifications at: samtec.com?QRF8



HIGH-SPEED SIGNAL & POWER COMBINATIONS

Q2™ Rugged Signal/Power

- Integral power/ground plane rated for up to 15.7 Amps
- Optional integral power pins rated at 4 Amps
- Wide variety of standard high-speed mating cable assemblies
- Combination signal/power cable assemblies
- 0.635 mm pitch with choice of stack heights
- Rugged contact system with increased insertion depth
- See QMS/QFS Series



Integral Power / Ground Plane



Maximum Insertion Depth

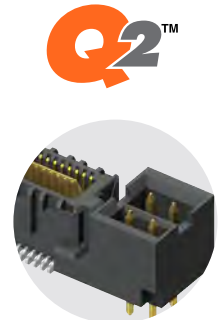

Optional Power Pins



Q Strip® High-Speed Signal/Power

- Integral power/ground plane rated for up to 25 Amps
- Wide variety of standard high-speed mating cables
- Low profile (5 mm) to elevated (25 mm) stack heights
- Choice of pitches: QTH/QSH Series (0.50 mm pitch), QTS/QSS Series (0.635 mm pitch), and QTE/QSE Series (0.80 mm pitch)

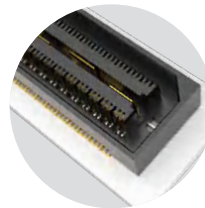

Single-Ended or Differential Pair

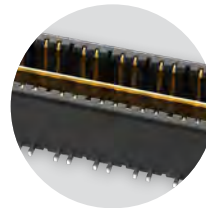

Surface Mount or Through-Hole Power Planes



Low Profile to Elevated Stack Heights



Q Rate® Slim Body High-Speed Signal/Power

- Widely accepted industry standard power/ground plane rated for up to 8.5 Amps
- Signal integrity optimized Edge Rate® contact is robust when “zippered” during unmating
- Slim 4.60 mm body width on 0.80 mm pitch
- 7 mm to 14 mm stack heights
- See QRM8/QRF8 Series

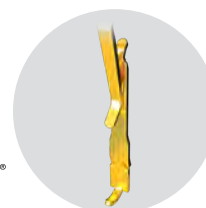

Edge Rate® Contact System



Integral Power / Ground Plane



RIGHT-ANGLE & EDGE MOUNT HIGH-SPEED GROUND PLANE CONNECTORS

- Right-Angle and Edge Mount designs for coplanar and perpendicular mating
- Q Strip® Right-Angle High-Speed Connectors on 0.50 mm & 0.635 mm pitches
- Q2™ Right-Angle & Edge Mount Rugged High-Speed Connectors on 0.635 mm pitch
- Q Rate® Right-Angle Slim Body High-Speed Connectors on 0.80 mm pitch
- Visit samtec.com/QSeries for complete specifications and ordering information



Q STRIP® HIGH-SPEED GROUND PLANE CONNECTORS

(0.50 mm) .0197" PITCH RIGHT-ANGLE GROUND PLANE HEADERS & SOCKETS



QTH-RA
Board Mates:
QSH

QSH-RA
Board Mates:
QTH

SERIES	PINS PER ROW NO. OF PAIRS	01	PLATING	TYPE	RA	OTHER OPTION
QTH Header	-030, -060, -090 -D = (60 total pins per bank)		-F = Gold Flash on contact, Matte Tin on tails	-D = Single-Ended		-PGP = Plastic Guide Post (QTH only)
QSH Socket	-020, -040, -060 -D-DP = (20 pairs per bank)		-L = 10 μ" (0.25 μm) Gold contact, Matte Tin on tails	-D-DP = Differential Pair		-GP = Guide Post Holes (QSH only)
						-K = Polyimide film Pick & Place Pad

View complete specifications at: samtec.com?QTH-RA or samtec.com?QSH-RA

(0.635 mm) .025" PITCH RIGHT-ANGLE GROUND PLANE HEADERS & SOCKETS

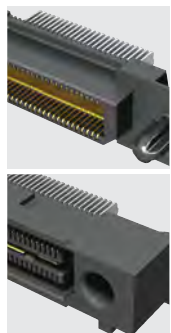

QTS-RA
Board Mates:
QSS

QSS-RA
Board Mates:
QTS

Cable Mates:
SQCD

SERIES	POSITIONS PER ROW	01	PLATING	D	RA	WT	OTHER OPTION
QTS Header	-025, -050, -075 (50 total Positions per bank)		-F = Gold Flash on Signal Pins and Ground Plane, Matte Tin on tails			-WT = Weld Tab (N/A with -025 Positions)	-SP = Solder Pin (QTS only)
QSS Socket			-L = 10 μ" (0.25 μm) Gold on Signal Pins and Ground Plane, Matte Tin on tails				

View complete specifications at: samtec.com?QTS-RA or samtec.com?QSS-RA

Note:
Some lengths, styles and options are non-standard, non-returnable.

Q2™ HIGH-SPEED GROUND PLANE CONNECTORS

(0.635 mm) .025" PITCH RIGHT-ANGLE GROUND PLANE HEADERS & SOCKETS

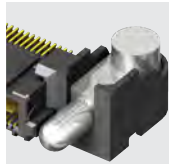

QMS-RA
Board Mates:
QFS



QFS-RA
Board Mates:
QMS

SERIES	PINS PER ROW NO. OF PAIRS	01	PLATING	TYPE	RA	MG	OTHER OPTION	PACKAGING
QMS Header	-026, -052, -078 -D = (52 total pins per bank)		-SL = 10 μ" (0.25 μm) Gold on Signal Pins and Ground Plane, Matte Tin on tails	-D = Single- Ended -D-DP = Differential Pair		-MG = Metal Guide Post (QMS only)	-K = Polyimide film Pick & Place Pad	Leave blank for Tray Packaging -TR = Tape & Reel (-016, -026, -032 & -052 only) -FR = Full Reel Tape & Reel (must order max. quantity per reel; contact Samtec for quantity breaks) (-016, -026, -032 & -052 only)
QFS Socket	-016, -032, -048 -D-DP = (16 pairs per bank)							

View complete specifications at: samtec.com?QMS-RA or samtec.com?QFS-RA

(0.635 mm) .025" PITCH EDGE MOUNT GROUND PLANE HEADERS & SOCKETS

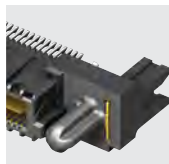

QMS-EM
Board Mates:
QFS



QFS-EM
Board Mates:
QMS

SERIES	POSITIONS PER ROW	01	PLATING	D	EM2	END OPTION	PACKAGING
QMS Header	-026, -052, -078		-SL = 10 μ" (0.25 μm) Gold on Signal Pins and Ground Plane, Matte Tin on tails			-PC4 = 4 Power Pins per end (QMS only)	Leave blank for Tray Packaging -TR = Tape & Reel (-026 & -052 only) -FR = Full Reel Tape & Reel (must order max. quantity per reel; contact Samtec for quantity breaks) (-026 & -052 only)
QFS Socket							

View complete specifications at: samtec.com?QMS-EM or samtec.com?QFS-EM

Q RATE® SLIM BODY HIGH-SPEED GROUND PLANE CONNECTORS

(0.80 mm) .0315" PITCH RIGHT-ANGLE SLIM BODY GROUND PLANE HEADERS & SOCKETS

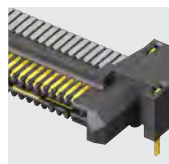

QRM8-RA
Board Mates:
QRF8
(-GP Required)

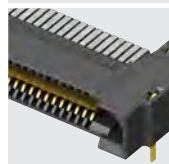

QRF8-RA
Board Mates:
QRM8
(-GP Required)

SERIES	POSITIONS PER ROW	01	PLATING	RA	GP	OPTION	PACKAGING
QRM8 Header	-026, -052, -078 (52 total positions per bank)		-L = 10 μ" (0.25 μm) Gold contact, Matte Tin on tails		-GP = Guide Post (Requires -GP on mating connector)	-K = (7.00 mm) .275" DIA Polyimide film Pick & Place Pad (-052 only)	Leave blank for Tray Packaging -TR = Tape & Reel (-026, -052 only) -FR = Full Reel Tape & Reel (must order max. quantity per reel; contact Samtec for quantity breaks) (-026 & -052 only)
QRF8 Socket							

Note:
Some lengths, styles and options
are non-standard, non-returnable.

View complete specifications at: samtec.com?QRM8-RA or samtec.com?QRF8-RA

RUGGED HIGH-SPEED STRIPS



NRZ	PAM4
28 Gbps	56 Gbps

FEATURES & BENEFITS

Edge Rate® rugged high-speed connector strips are designed for high-speed, high cycle applications, and enabled by Samtec's signal integrity-optimized Edge Rate® contact system.

- Up to 1.5 mm contact wipe for a reliable connection
- 20 to 200 positions
- Choice of 0.50 mm, 0.635 mm or 0.80 mm pitch
- 0.50 mm pitch system offers up to 40% PCB space savings vs. 0.80 mm pitch
- 0.635 mm pitch system with extremely slim 2.5 mm body width
- Rugged latching, extended guide posts and 360° shielding
- Severe Environment Testing qualified (ERM8/ERF8); aligns with MIL-DTL-55302. Visit samtec.com/set

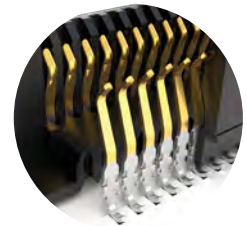

Signal integrity-optimized Edge Rate® contact system reduces broadside coupling



Rugged 360° shielding reduces EMI

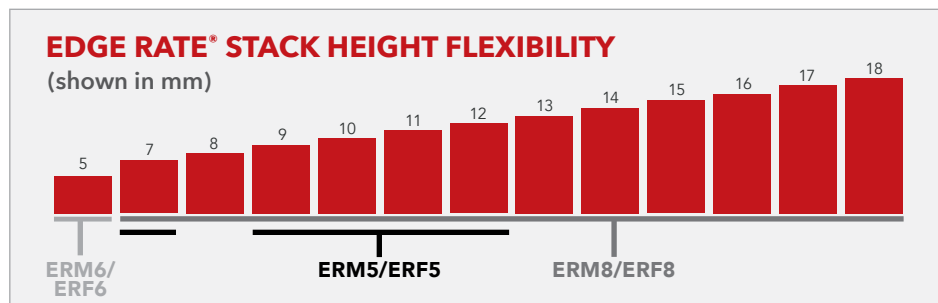

KEY SPECIFICATIONS

SERIES	PITCH	INSULATOR MATERIAL	TERMINAL MATERIAL	PLATING	OPERATING TEMP RANGE	CURRENT RATING	VOLTAGE RATING	LEAD-FREE SOLDERABLE
ERM5 / ERF5	0.50 mm	Black LCP	Phosphor Bronze or BeCu (ERM5), BeCu (ERF5)	Au or Sn over 50 μm* (1.27 μm) Ni	-55 °C to +125 °C	1.5 A	190 VAC/ 269 VDC	Yes
ERM6 / ERF6	0.635 mm		Copper Alloy			1.4 A	155 VAC/ 219 VDC	
ERM8 / ERF8	0.80 mm		Phosphor Bronze or BeCu (ERM8), BeCu (ERF8)			2.2 A	225 VAC/ 318 VDC	

(0.50 mm) .0197" PITCH • RUGGED HIGH-SPEED STRIPS

SERIES	POSITIONS PER ROW	LEAD STYLE	PLATING OPTION	DV	OPTIONS	PICK & PLACE PAD	"X"R
ERM5 = Header	-010, -020, -030, -040, -050, -060, -070, -075	-02.0 = 2 mm Body Height (ERM5 only) (Not available with -K-TR)	-L = 10 μm (0.25 μm) Gold on contact, Matte Tin on Tail		(Not required. Only specify one option in callout. Will only mate with a corresponding option)	(Required in callout)	-TR = Tape & Reel
ERF5 = Socket		-04.0 = 4 mm Body Height (ERM5 only)			-FL = Friction Lock (max. -030 positions)	-K = (3.50 mm) .138" DIA Polyimide Film Pick & Place Pad (ERM5 only)	-FR = Full Reel Tape & Reel (must order maximum quantity per reel; contact Samtec for quantity breaks)
		-05.0 = 5 mm Body Height			-WT = Weld Tab	-L = Latching (Available with -02.0 and -05.0 Lead Styles only)	
		-07.0 = 7 mm Body Height (ERF5 only & Available up to 50 positions only)				-P = Plastic Pick & Place Pad	

ERM5
Board Mates:
ERF5

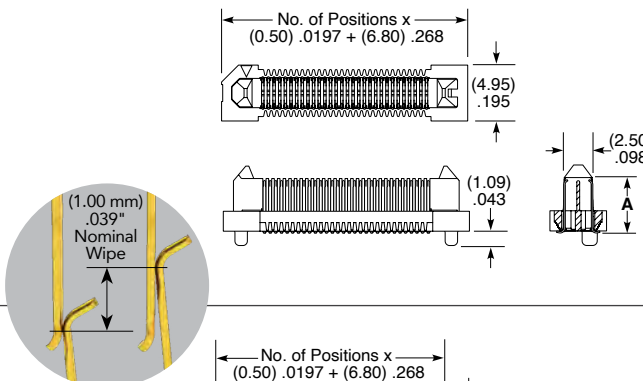
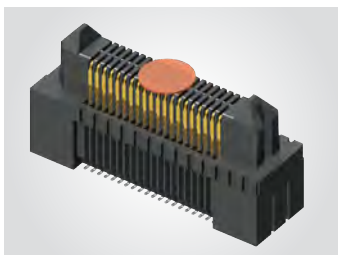

LEAD STYLE	A (ERM5)	B (ERF5)
-02.0	(4.84) .191	N/A
-04.0	(6.84) .269	N/A
-05.0	(7.84) .309	(4.91) .193
-07.0	N/A	(6.91) .272

ERF5
Board Mates:
ERM5

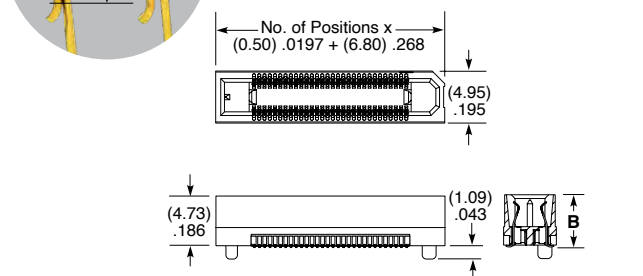

ERM5 LEAD STYLE	MATED HEIGHT*	
	ERF5 LEAD STYLE -05.0	ERF5 LEAD STYLE -07.0
-02.0	(7.00) .276	(9.00) .354
-04.0	(9.00) .354	(11.00) .433
-05.0	(10.00) .394	(12.00) .472

*Processing conditions will affect mated height.

View complete specifications at: samtec.com?ERM5 or samtec.com?ERF5

ERF5	POSITIONS PER ROW	01	PLATING OPTION	D	RA	"X"R
------	-------------------	----	----------------	---	----	------

Right-Angle Socket

-010, -020, -030, -040, -050

-L
= 10 μm (0.25 μm) Gold on contact, Matte Tin on tail

-TR
= Tape & Reel

ERF5-RA
Board Mates:
ERM5

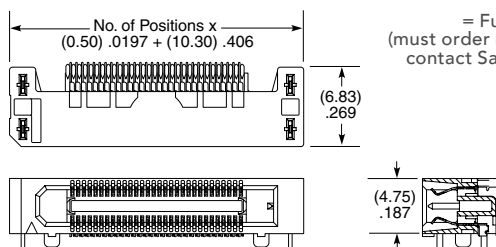

-FR
= Full Reel Tape & Reel (must order maximum quantity per reel; contact Samtec for quantity breaks)

Note:
Some lengths, styles and options are non-standard, non-returnable.

View complete specifications at: samtec.com?ERF5-RA

(0.635 mm) .025" PITCH • RUGGED HIGH-SPEED HEADERS & SOCKETS

ERM6	POSITIONS PER ROW	01.5	PLATING OPTION	DV	A	OPTION	K	"X"R
-------------	--------------------------	-------------	-----------------------	-----------	----------	---------------	----------	-------------

**-10, -20, -30,
-40, -50, -60**
(Standard Sizes)

-L
= 10 μ" (0.25 μm)
Gold on contact,
Matte Tin on tail

(Leave Blank for
No Weld Tab)

-WT
= Weld Tab

-TR
= Tape & Reel

-FR
= Full Reel Tape & Reel
(must order maximum quantity
per reel; contact Samtec for
quantity breaks)

ERM6
Board Mates:
ERF6

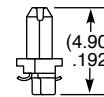
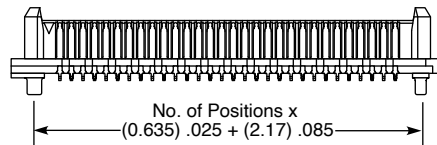
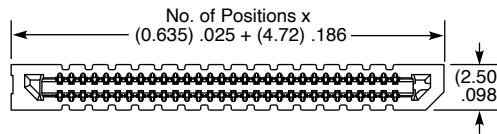
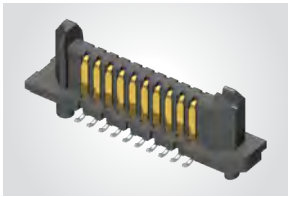

MATED HEIGHT*

ERF6 LEAD STYLE	ERM6 LEAD STYLE
	-01.5
-03.5	(5.00) .197

*Processing conditions will affect mated height.

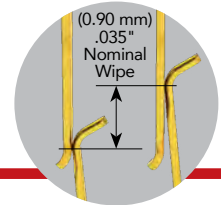

View complete specifications at: samtec.com?ERM6

ERF6	POSITIONS PER ROW	03.5	PLATING OPTION	DV	A	OPTION	K	"X"R
-------------	--------------------------	-------------	-----------------------	-----------	----------	---------------	----------	-------------

**-10, -20, -30,
-40, -50, -60**
(Standard Sizes)

-L
= 10 μ" (0.25 μm)
Gold on contact,
Matte Tin on tail

(Leave Blank for
No Weld Tab)

-WT
= Weld Tab

-TR
= Tape & Reel

-FR
= Full Reel Tape & Reel
(must order maximum quantity
per reel; contact Samtec for
quantity breaks)

ERF6
Board Mates:
ERM6

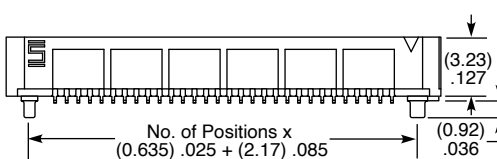
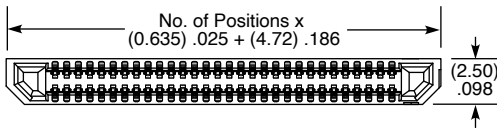

MATED HEIGHT*

ERF6 LEAD STYLE	ERM6 LEAD STYLE
	-01.5
-03.5	(5.00) .197

*Processing conditions will affect mated height.

Notes:
Kapton pad and tape & reel
packaging are standard.

Some lengths, styles and
options are non-standard,
non-returnable.

View complete specifications at: samtec.com?ERF6

(0.80 mm) .0315" PITCH • RUGGED HIGH-SPEED HEADERS & SOCKETS

TYPE	POSITIONS PER ROW	LEAD STYLE	PLATING OPTION	DV	OPTIONS	"X"R
------	-------------------	------------	----------------	----	---------	------

ERM8
= Header
ERF8
= Socket

-005, -010, -011, -013, -020, -025, -030, -035, -040, -049, -050, -060, -070, -075, -100

(100 Position Only Available with ERM8-09.0 & ERF8-05.0 Lead Styles; -L or -EGP N/A)

SPECIFY LEAD STYLE FROM CHART

-L
= 10 μ" (0.25 μm)
Gold on contact,
Matte Tin on tail

-DS
= Differential Pair
(ERM8 -05.0 Lead Style with -010, -013, -025, -049 Positions only) (-P not available)

-L
= Latching
(ERM8 -03.0, -05.0 & -09.0 Lead Styles only & -EGP Option not available)
(ERF8 -05.0, -07.0 & -09.0 Lead Style only, -L & -EGP Options not available)

-TR
= Tape & Reel
(100 Positions N/A)

-FR
= Full Reel Tape & Reel (must order maximum quantity per reel; contact Samtec for quantity breaks) (100 Positions N/A)

ERM8
Board Mates:
ERF8

Cable Mates:
ERCD, ERDP

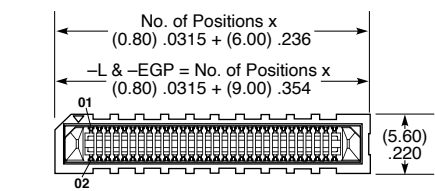
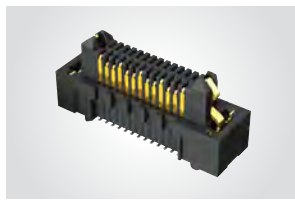

ERM8 LEAD STYLE	A	B
-02.0	(5.97) .235	N/A
-03.0	(6.97) .274	(1.60) .063
-05.0	(8.91) .351	(1.17) .046
-08.0	(11.91) .469	N/A
-09.0	(12.91) .508	(1.60) .063

-EGP
= Extended Guide Post
(ERM8 -05.0 & ERF8 -07.0 Lead Style Only & -L Option not available)

-DSP
= Differential Pair with Extended Guide Post
(ERM8 -05.0 Lead Style with -013 and -025 Positions only)

-K
= Polyimide Film Pick & Place Pad
(-02.0 Lead Style not available)

-P
= Pick & Place Pad
(ERM8 -02.0, -03.0 & -05.0 Lead Styles only) (-DS not available)

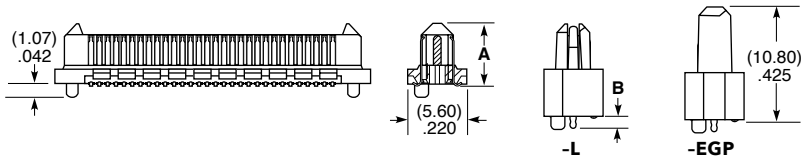

View complete specifications at: samtec.com?ERM8

ERF8
Board Mates:
ERM8

ERF8
Cable Mates:
ERCD, ERDP

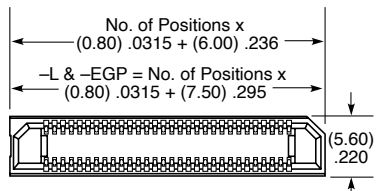
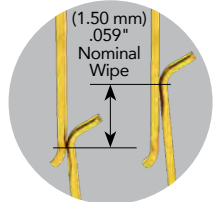
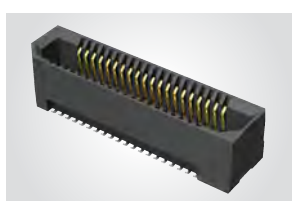

ERF8 LEAD STYLE	C	D
-05.0	(5.34) .210	(1.60) .063
-07.0	(7.25) .285	(1.17) .046
-09.0	(9.34) .368	(1.60) .063

ERM8 LEAD STYLE	MATED HEIGHT*		
	ERF8 LEAD STYLE -05.0	-07.0	-09.0
-02.0	(7.00) .276	(9.00) .354	(11.00) .433
-03.0	(8.00) .315	(10.00) .394	(12.00) .472
-05.0	(10.00) .394	(12.00) .472	(14.00) .551
-08.0	(13.00) .512	(15.00) .591	(17.00) .669
-09.0	(14.00) .551	(16.00) .630	(18.00) .709

*Processing conditions will affect mated height.

Notes:
Severe Environment Testing qualified; aligns with MIL-DTL-55302. Visit samtec.com/set

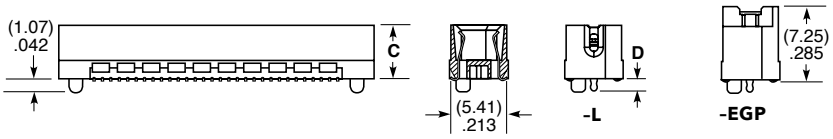

Some lengths, styles and options are non-standard, non-returnable.

View complete specifications at: samtec.com?ERF8

See pg 52-53 for Right-Angle & Edge Mount options, pg 54 for Shielded options.

(0.80 mm) .0315" PITCH • RIGHT-ANGLE & EDGE MOUNT HIGH-SPEED HEADERS

ERM8	POSITIONS PER ROW	01	PLATING OPTION	D	RA	OPTIONS	"X"R
------	-------------------	----	----------------	---	----	---------	------

Right-Angle Terminal

-010, -013, -020, -025, -030, -040, -049, -050, -060, -070, -075

-L
= 10 μ" (0.25 μm)
Gold on contact area, Matte Tin on tail

-K
= (6.00 mm) .236" DIA
Polyimide Film Pick & Place Pad

-TR
= Tape & Reel

-L
= Latching

-FR
= Full Reel Tape & Reel (must order maximum quantity per reel; contact Samtec for quantity breaks)

-DS
= Differential Pair (-013, -025 Positions only) (Hot Swap)

ERM8-RA
Board Mates: **ERF8**
Cable Mates: **ERCD**

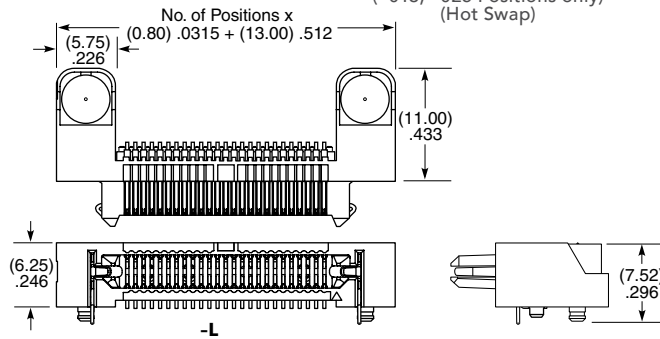
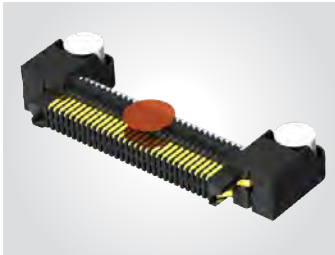

View complete specifications at: samtec.com?ERM8-RA

ERM8	POSITIONS PER ROW	01	PLATING OPTION	D	EM2	OPTIONS	"X"R
------	-------------------	----	----------------	---	-----	---------	------

Edge Mount Terminal

-010, -013, -020, -025, -030, -040, -049, -050, -060, -070, -075

-L
= 10 μ" (0.25 μm)
Gold on contact area, Matte Tin on tail

= (1.60 mm) .062" Thick PCB

-L
= Latching
(Mates to ERF8 Lead Style -05.0 or -RA Only)

-TR
= Tape & Reel

-DS
= Differential Pair (-013 & -025 Positions only) (Hot Swap)

-FR
= Full Reel Tape & Reel (must order maximum quantity per reel; contact Samtec for quantity breaks)

-EGPS
= Extended Guide Post Shield (-010, -020, -025, -030 Positions Only)

-DSS
= Differential Pair + Extended Guide Post Shield (-025 Positions Only) (Hot Swap)

ERM8-EM
Board Mates: **ERF8**
Cable Mates: **ERCD**

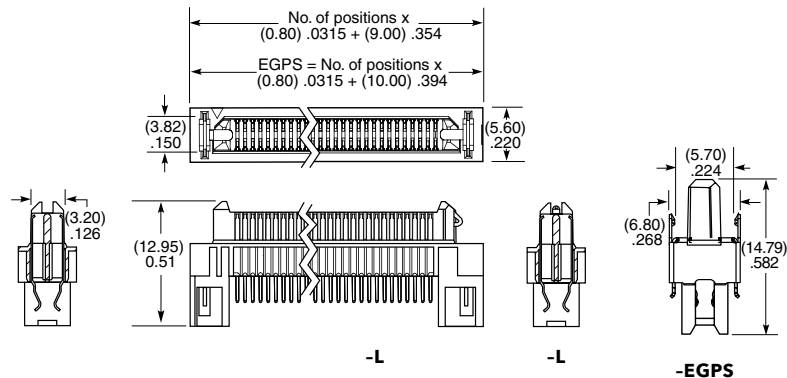
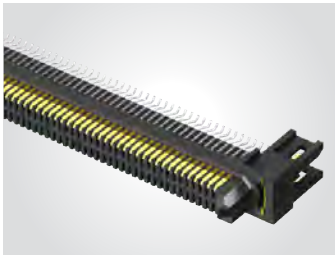

Note:
Some lengths, styles and options are non-standard, non-returnable.

View complete specifications at: samtec.com?ERM8-EM

(0.80 mm) .0315" PITCH • RIGHT-ANGLE & EDGE MOUNT HIGH-SPEED SOCKETS

ERF8	POSITIONS PER ROW	01	PLATING OPTION	D	RA	OPTIONS	"X"R
------	-------------------	----	----------------	---	----	---------	------

Right-Angle Socket

-010, -013, -020,
-025, -030, -040,
-049, -050, -060,
-070, -075

-L
= 10 μ" (0.25 μm)
Gold on contact
area, Matte Tin
on tail

-L
= Latching
(N/A with -EGP Option)

-EGP
= Extended Guide Post
(N/A with -L Option)

-TR
= Tape & Reel

-FR
= Full Reel
Tape & Reel
(must order maximum
quantity per reel;
contact Samtec for
quantity breaks)

ERF8-RA
Board Mates:
ERM8
Cable Mates:
ERCD, ERDP

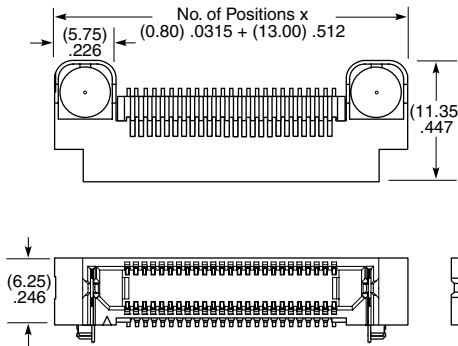

View complete specifications at: samtec.com?ERF8-RA

ERF8	POSITIONS PER ROW	01	PLATING OPTION	D	EM2	OPTIONS	"X"R
------	-------------------	----	----------------	---	-----	---------	------

Edge Mount Socket

-010, -013,
-020, -025,
-030, -040,
-049, -050,
-060, -070,
-075

-L
= 10 μ" (0.25 μm)
Gold on contact
area, Matte Tin
on tail

= (1.60 mm)
.062" Thick
PCB

-EGPS
= Extended Guide Post Shield
(-010, -020, -025, -030 Pos. only)

-TR
= Tape & Reel

-FR
= Full Reel Tape & Reel
(must order maximum
quantity per reel;
contact Samtec for
quantity breaks)

ERF8-EM
Board Mates:
ERM8

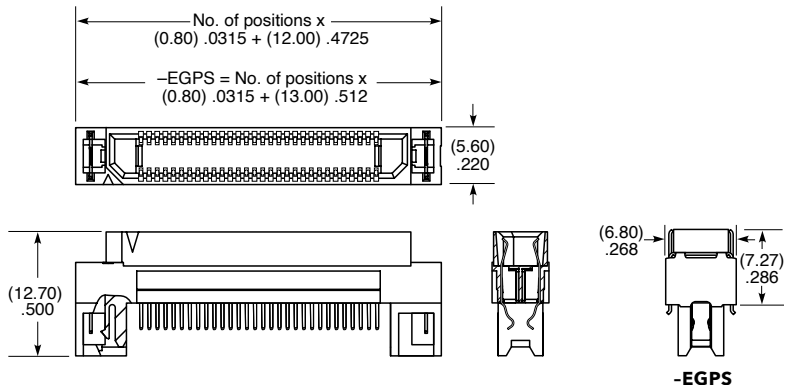

Note:
Some lengths, styles and
options are non-standard,
non-returnable.

View complete specifications at: samtec.com?ERF8-EM

(0.80 mm) .0315" PITCH • SHIELDED HIGH-SPEED HEADERS & SOCKETS

TYPE	POSITIONS PER ROW	LEAD STYLE	PLATING OPTION	DV	OPTIONS	"X"R
ERM8 = Shielded Terminal	-010, -020, -025, -030	-02.0 = 2 mm (ERM8 with -S only)	-L = 10 μ" (0.25 μm) Gold on contact, Matte Tin on tail		-S = Shield (Lead Styles: ERM8 -02.0 only; ERF8 -05.0 only)	-TR = Tape & Reel
ERF8 = Shielded Socket		-05.0 = 5 mm (ERF8 with -S & ERM8 with -EGPS & -DSS only)			-EGPS = Extended Guide Post Shield (Lead Styles: ERM8 -05.0 & -09.0 only; ERF8 -07.0 only)	-FR = Full Reel Tape & Reel (must order maximum quantity per reel; contact Samtec for quantity breaks)
		-07.0 = 7 mm (ERF8 with -EGPS only)			-DSS = Differential Pair with Extended Guide Post Shield (ERM8 only, with -05.0 & -09.0 Lead Styles, -10 & -025 Positions only)	
		-09.0 = 9 mm (ERM8 with -EGPS & -DSS only)			-K = Polyimide Film Pick & Place Pad (-02.0 Lead Style N/A)	
					-P = Pick & Place Pad (ERM8 -02.0 & -05.0 Lead Styles only)	

ERM8-S Board Mates:
See "Mated Height" Chart

(Note: ERF8-S does not mate with ERM8-EGPS)

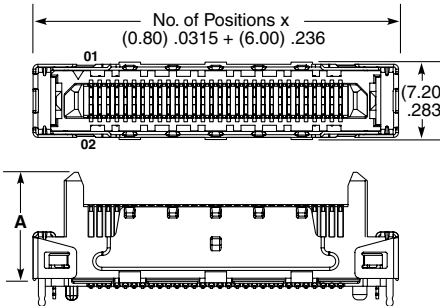
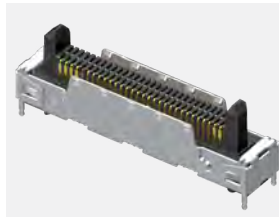

LEAD STYLE	A	B
-05.0	(9.87) .389	(10.81) .425
-09.0	(13.87) .546	(14.81) .583

-S OPTION -EGPS OR -DSS OPTION

View complete specifications at: samtec.com?ERM8

ERF8-S Board Mates:
See "Mated Height" Chart

(Note: ERM8-EGPS does not mate with ERF8-S)

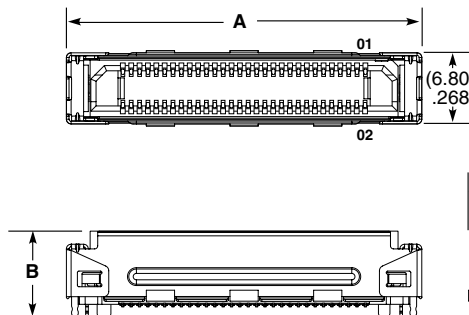

LEAD STYLE	B (-S)	B (-EGPS)
-05.0	(5.90) .232	N/A
-07.0	N/A	(7.42) .292

Notes:
Severe Environment Testing qualified; aligns with MIL-DTL-55302. Visit samtec.com/set

Some lengths, styles and options are non-standard, non-returnable.

POSITIONS PER ROW	A
-010	(18.00) .71
-020	(26.00) 1.02
-025	(30.00) 1.18
-030	(34.00) 1.34

-S OPTION

View complete specifications at: samtec.com?ERF8

ULTRA MICRO INTERCONNECTS

SPACE SAVING DESIGNS • RUGGED HERMAPHRODITIC • ULTRA FINE PITCH

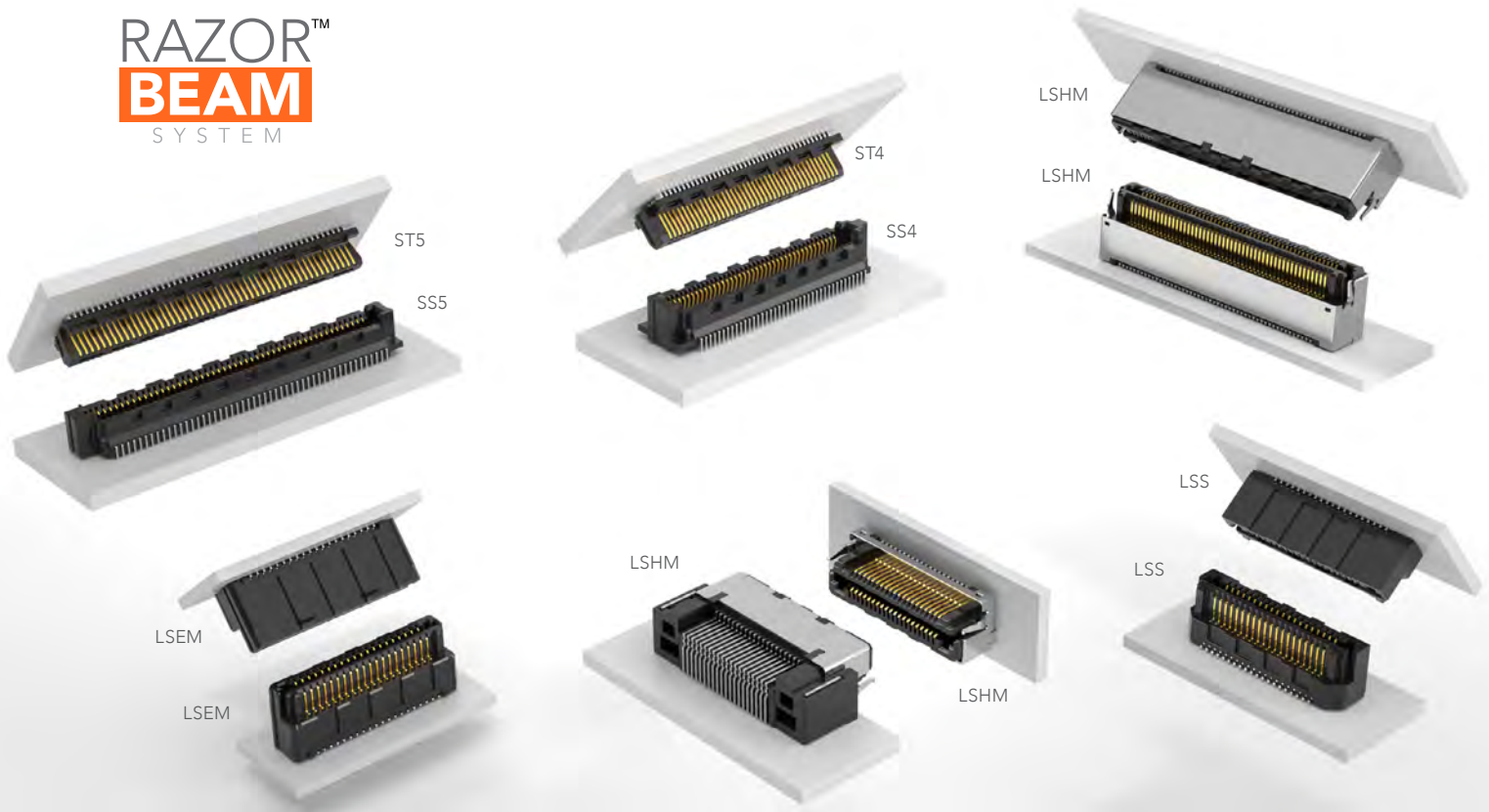

56-58

RAZOR BEAM™

0.50 mm Pitch Hermaphroditic Connectors (LSHM)	56-57
0.635 mm Pitch Hermaphroditic Connectors (LSS)	58
0.80 mm Pitch Hermaphroditic Connectors (LSEM)	58

59-60

MICRO BLADE & BEAM STRIPS

0.40 mm Pitch Low Profile Strips (ST4, SS4)	59
0.50 mm Pitch Low Profile Strips (ST5, SS5)	60

FINE PITCH SELF MATING CONNECTORS

0.50 mm, 0.635 mm and 0.80 mm PITCH

FEATURES & BENEFITS

- Ten stack height options from 5.00 mm to 12.00 mm
 - 0.50 mm, 0.635 mm or 0.80 mm pitches
 - Audible click when mated
 - Mating and unmating forces approximately 4-6x greater than typical micro pitch connectors
 - Self-mating system reduces inventory cost
 - Parallel, perpendicular and coplanar systems
 - Shielded and lubricated options
 - Severe Environment Testing qualified (LSHM); aligns with MIL-DTL-55302.
- Visit samtec.com/set

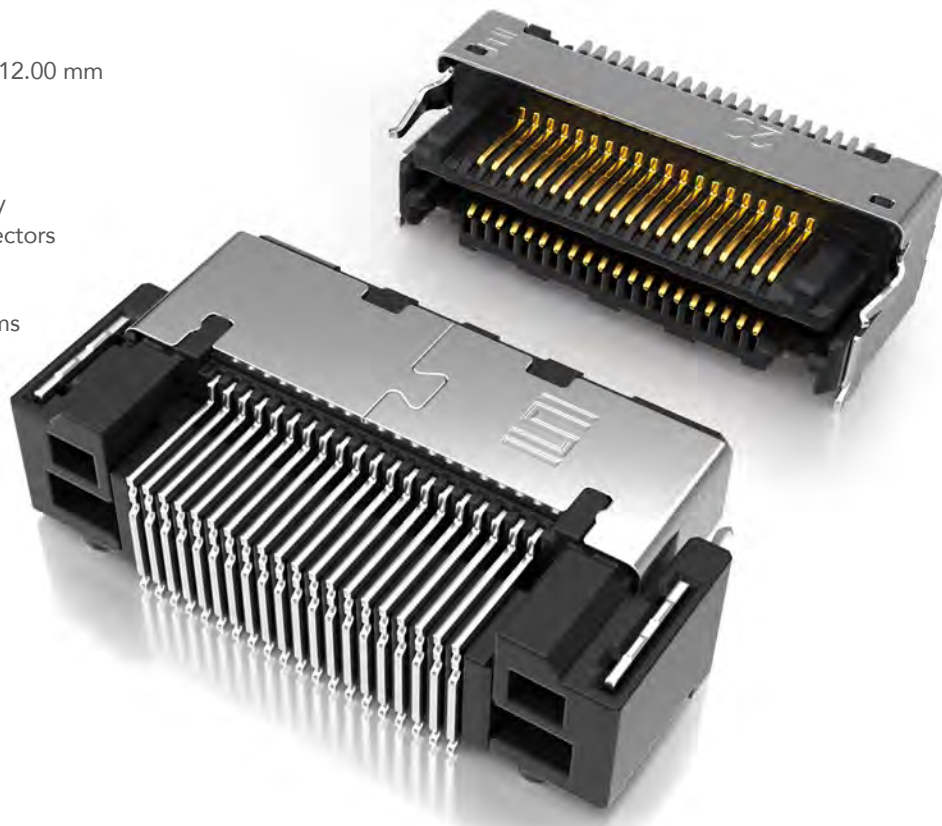

SLIM BODY DESIGNS (40 total positions each)

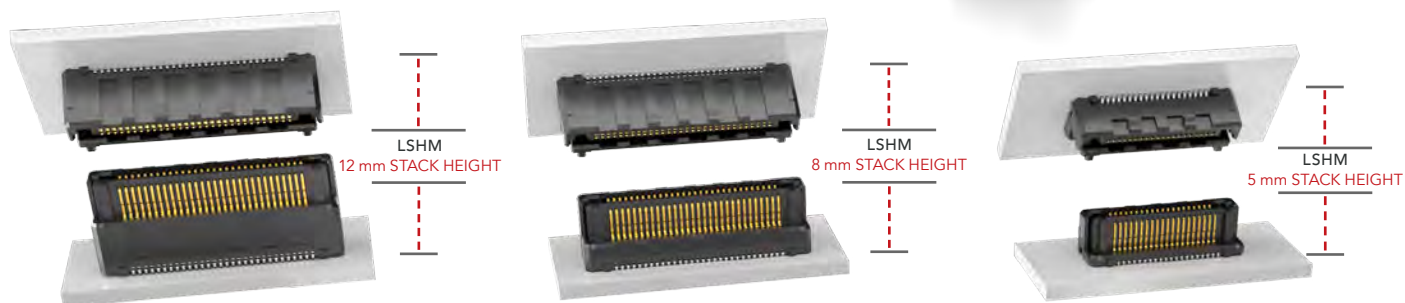

KEY SPECIFICATIONS

INSULATOR MATERIAL	CONTACT MATERIAL	PLATING	OPERATING TEMP RANGE	CURRENT RATING	VOLTAGE RATING	SMT COPLANARITY	LEAD-FREE SOLDERABLE
Black LCP	Phosphor Bronze	Au or Sn over 50 μ" (1.27 μm) Ni	-55 °C to +125 °C	LSHM: 2.0 A per pin LSS: 1.7 A per pin LSEM: 1.8 A per pin	LSHM: 160 VAC/226 VDC LSS: 300 VAC/424 VDC LSEM: 225 VAC/318 VDC	(0.10 mm) .004" max	Yes

(0.50 mm) .0197" PITCH • RUGGED HERMAPHRODITIC CONNECTORS

LSHM - **1** **NO. PINS PER ROW** - **LEAD STYLE** - **PLATING OPTION** - **TAIL OPTION** - **A** - **SHIELD OPTION** - **K** - **"X"R**

**05, 10, 20,
30, 40, 50**

(Vertical)
**Specify
LEAD
STYLE
from
chart**

-F
= Gold flash
on contact,
Matte Tin on tail

-DV
= Vertical

-S
= With
Shield

-K
= (3.50 mm)
.138" DIA
Polyimide
film Pick &
Place Pad

-TR
= Tape &
Reel

LSHM

Board Mates:

LSHM

Cable Mates:

HLCD

(Right-angle)

-01

= Standard

(Right-angle)

-L1

= Lubricated

-L
= 10 μ" (0.25 μm)
Gold on contact,
Matte Tin on tail

-DH
= Right-angle
(Lead style -01
& -L1 only)

-N
= Without
Shield

-RH
= Reverse
Right-angle
(Lead style -01
& -L1 only)

-FR
= Full Reel
Tape & Reel
(must order
maximum
quantity
per reel;
contact
Samtec for
quantity
breaks)

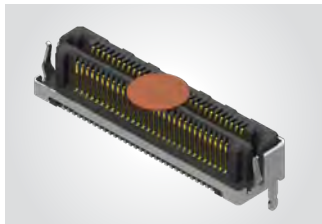

LEAD STYLE	MATED HEIGHT *
-02.5 & -02.5	(5.00) .196
-02.5 & -03.0	(5.50) .217
-03.0 & -03.0	(6.00) .236
-02.5 & -04.0	(6.50) .256
-03.0 & -04.0	(7.00) .276
-04.0 & -04.0	(8.00) .315
-02.5 & -06.0	(8.50) .335
-03.0 & -06.0	(9.00) .354
-04.0 & -06.0	(10.00) .394
-06.0 & -06.0	(12.00) .472

*Processing conditions will affect mated height.

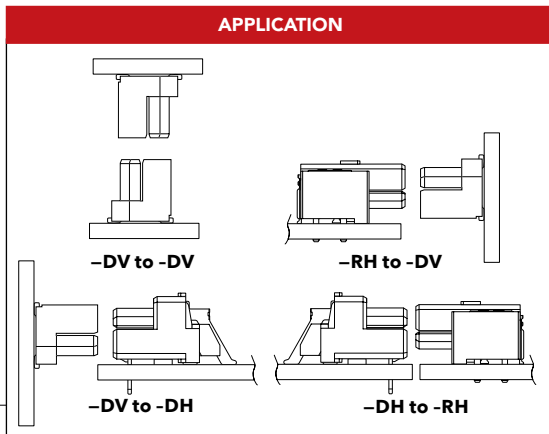

No. of positions x
(0.50) .0197
+ (4.70) .185

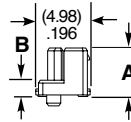

No. of positions x
(0.50) .0197
+ (2.00) .078

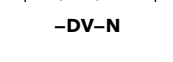

-DV-N

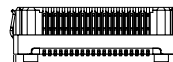
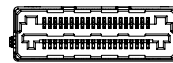

-DV-S

No. of positions
x (0.50) .0197
+ (4.95) .195

LEAD STYLE (STANDARD)	LEAD STYLE (LUBRICATED)	A	B
-02.5	-L2.5	(3.95) .156	(1.00) .039
-03.0	-L3.0	(4.45) .175	(1.50) .059
-04.0	-L4.0	(5.45) .215	(2.50) .098
-06.0	-L6.0	(7.45) .293	(4.50) .177

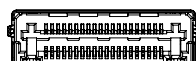
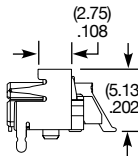
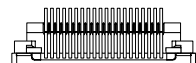
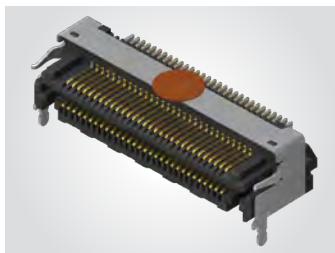

No. of positions
x (0.50) .0197
+ (4.95) .195

-DH-S

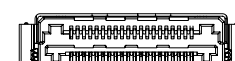
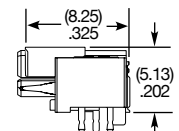
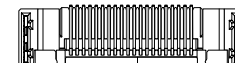

No. of positions
x (0.50) .0197
+ (2.65) .104

-RH-S



No. of positions
x (0.50) .0197
+ (4.70) .185

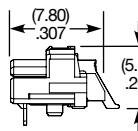

No. of positions
x (0.50) .0197
+ (1.90) .074

-DH-N

No. of positions
x (0.50) .0197
+ (7.70) .303

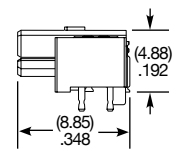
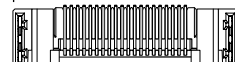

No. of positions
x (0.50) .0197
+ (6.60) .259

-RH-N

Notes:
Severe Environment Testing
qualified; aligns with MIL-DTL-55302.
Visit samtec.com/set

Some lengths, styles and options are
non-standard, non-returnable.

View complete specifications at: samtec.com?LSHM

(0.635 mm) .025" PITCH • RUGGED HERMAPHRODITIC CONNECTORS

LSS	1	NO. PINS PER ROW	LEAD STYLE	PLATING OPTION	DV	A	OPTION	"X"R
		10, 20, 30, 40, 50	Specify LEAD STYLE from chart	-F = Gold flash on contact, Matte Tin on tail -L = 10 μ" (0.25 μm) Gold on contact, Matte Tin on tail			-K = (3.50 mm) .138" DIA Polyimide film Pick & Place Pad	Leave blank for Tray Packaging -TR = Tape & Reel -FR = Full Reel Tape & Reel (must order maximum quantity per reel; contact Samtec for quantity breaks)

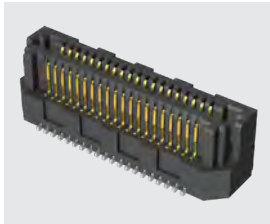

LEAD STYLE	A	B
-01	(4.45) .1752	(1.59) .0628
-02	(7.45) .2933	(4.59) .1808
-03	(5.45) .2146	(2.59) .1021

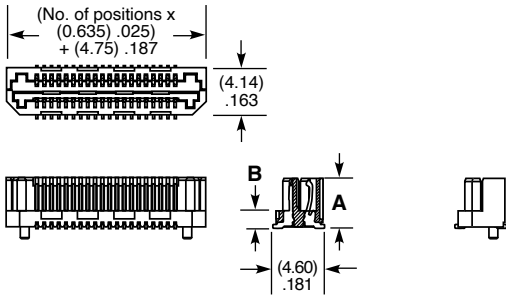

LEAD STYLE	MATED HEIGHT *
-01 & -01	(6.00) .236
-01 & -03	(7.00) .276
-03 & -03	(8.00) .315
-01 & -02	(9.00) .354
-02 & -03	(10.00) .394
-02 & -02	(12.00) .472

View complete specifications at: samtec.com?LSS

(0.80 mm) .0315" PITCH • RUGGED HERMAPHRODITIC CONNECTORS

LSEM	1	NO. PINS PER ROW	LEAD STYLE	PLATING OPTION	TAIL OPTION	A	N	K	"X"R
		20, 30, 40, 50	Specify LEAD STYLE from chart	-F = Gold flash on contact, Matte Tin on tail -L = 10 μ" (0.25 μm) Gold on contact, Matte Tin on tail	-DV = Vertical -DH = Right-angle (Lead style -01 only)			-K = (3.50 mm) .138" DIA Polyimide film Pick & Place Pad	-TR = Tape & Reel -FR = Full Reel Tape & Reel (must order maximum quantity per reel; contact Samtec for quantity breaks)



LEAD STYLE	A	B
-01 (-DH only)	N/A	NA
-03.0	(4.45) .175	(1.50) .059
-04.0	(5.45) .215	(2.50) .098
-06.0	(7.45) .293	(4.50) .177

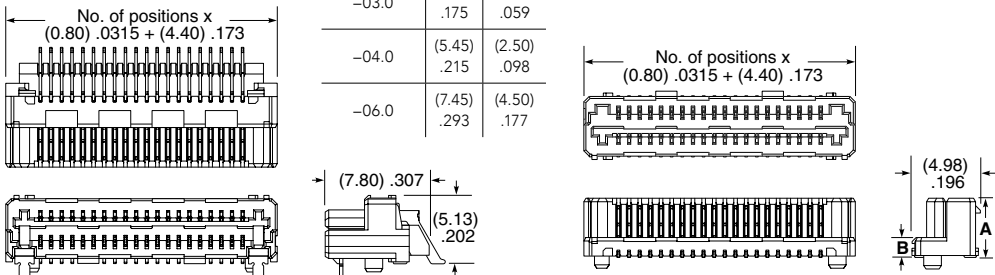

LEAD STYLE	MATED HEIGHT *
-03.0 & -03.0	(6.00) .236
-03.0 & -04.0	(7.00) .276
-04.0 & -04.0	(8.00) .315
-03.0 & -06.0	(9.00) .354
-04.0 & -06.0	(10.00) .394
-06.0 & -06.0	(12.00) .472

Note: Some lengths, styles and options are non-standard, non-returnable.

View complete specifications at: samtec.com?LSEM

MICRO BLADE & BEAM SOCKET & HEADER

28
Gbps

(0.40 mm) .0158" PITCH • SS4/ST4 SERIES

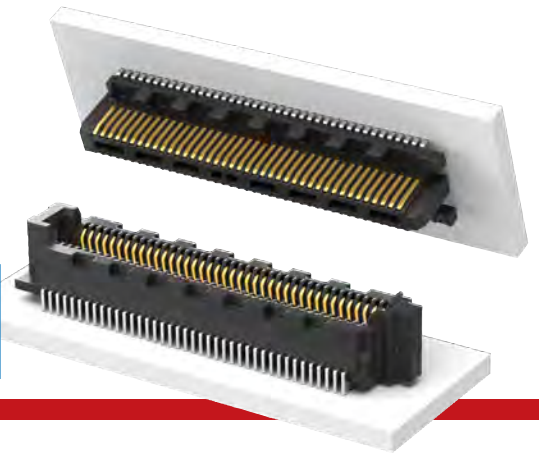

SS4
Mates:
ST4

ST4
Mates:
SS4

SPECIFICATIONS

Insulator Material:
Black LCP
Contact Material:
Phosphor Bronze
Plating:
Au or Sn over
50 μ" (1.27 μm) Ni
Operating Temp Range:
-55 °C to +125 °C
Current Rating:
1.6 A per pin
(2 pins powered)
Voltage Rating:
155 VAC/219 VDC

PROCESSING

Lead-Free Solderable:
Yes
SMT Lead Coplanarity:
(0.10 mm) .004" max

SS4	POSITIONS PER ROW	LEAD STYLE	PLATING OPTION	D	K	"X"R
-----	-------------------	------------	----------------	---	---	------

-10, -20,
-30, -40, -50

-3.00
= 3.00 mm

-3.50
= 3.50 mm

-L
= 10 μ"
(0.25 μm)
Gold on contact,
Matte Tin on tail

(Required in callout)

-K
= (3.50 mm)
.138" DIA
Polyimide
Film
Pick &
Place Pad

(Required in callout)

-TR
= Tape & Reel

-FR
= Full Reel
Tape & Reel
(must order max.
quantity per reel;
contact Samtec for
quantity breaks)

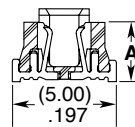
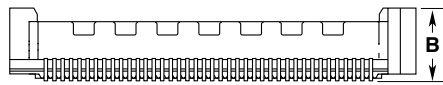
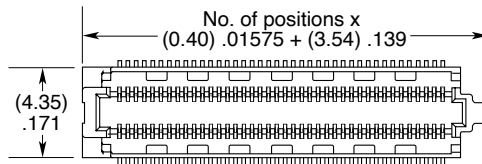

LEAD STYLE	A	B
-3.00	(2.85) .112	(3.50) .138
-3.50	(3.35) .132	(4.00) .157

ST4	POSITIONS PER ROW	LEAD STYLE	PLATING OPTION	D	P	"X"R
-----	-------------------	------------	----------------	---	---	------

-10, -20,
-30, -40, -50

-1.00
= 1.00 mm

-1.50
= 1.50 mm

-2.50
= 2.50 mm

-L
= 10 μ"
(0.25 μm)
Gold on contact,
Matte Tin on tail

(Required in callout)

-P
= Pick &
Place Pad

(Required in callout)

-TR
= Tape & Reel

-FR
= Full Reel
Tape & Reel
(must order max.
quantity per reel;
contact Samtec for
quantity breaks)

MATED HEIGHT *

ST4 LEAD STYLE	SS4 LEAD STYLE	
	-3.00	-3.50
-1.00	(4.00 mm) .157"	(4.50 mm) .177"
-1.50	(4.50 mm) .177"	(5.00 mm) .197"
-2.50	(5.50 mm) .217"	(6.00 mm) .236"

*Processing conditions will affect mated height.

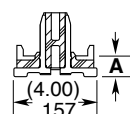
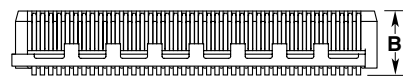
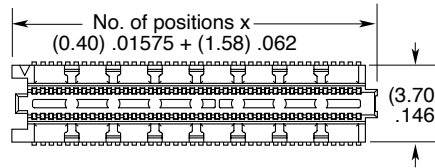

LEAD STYLE	A	B
-1.00	(1.00) .039	(3.08) .121
-1.50	(1.50) .059	(3.58) .141
-2.50	(2.50) .098	(4.58) .180

Note:
Some lengths, styles and options are non-standard, non-returnable.

MICRO BLADE & BEAM SOCKET & HEADER

(0.50 mm) .0197" PITCH • SS5/ST5 SERIES

PAM 4

56
Gbps

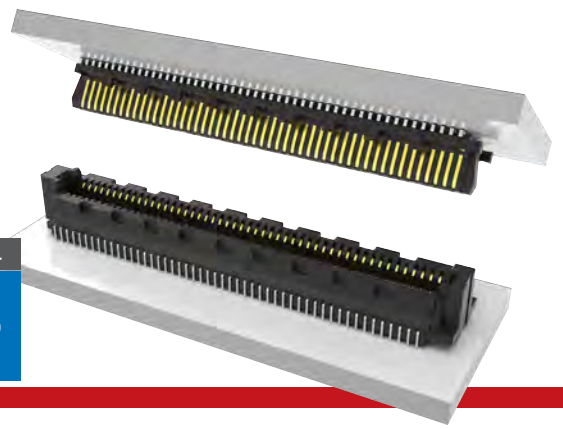

SS5
Mates:
ST5

ST5
Mates:
SS5

SPECIFICATIONS

Insulator Material:
Black LCP
Contact Material:
Phosphor Bronze
Plating:
Au or Sn over
50 μ" (1.27 μm) Ni
Operating Temp Range:
-55 °C to +125 °C
Current Rating:
1.5 A per pin
(2 pins powered)
Voltage Rating:
200 VAC/283 VDC

PROCESSING

Lead-Free Solderable:
Yes
SMT Lead Coplanarity:
(0.10 mm) .004" max

OTHER SOLUTIONS

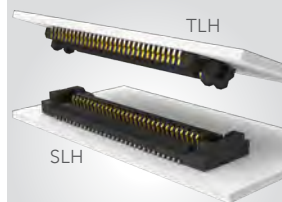

Ultra-low profile options:
www.samtec.com?SLH
www.samtec.com?TLH

ALSO AVAILABLE
Contact Samtec

Other lead styles

Note:
Some lengths, styles and options are non-standard, non-returnable.

SS5	NO. OF POSITIONS	LEAD STYLE	PLATING OPTION	D	K	"X"R
-----	------------------	------------	----------------	---	---	------

-10, -15, -20,
-30, -40, -50,
-60, -70, -80
(Per Row)

-3.00
= 3.00 mm
-3.50
= 3.50 mm

-L
= 10 μ"
(0.25 μm)
Gold on contact,
Matte Tin on tail

(Required in callout)

-K
= (3.50 mm)
.138" DIA
Polyimide
Film
Pick &
Place Pad

(Required in callout)

-TR
= Tape & Reel

-FR
= Full Reel
Tape & Reel
(must order max.
quantity per reel;
contact Samtec for
quantity breaks)

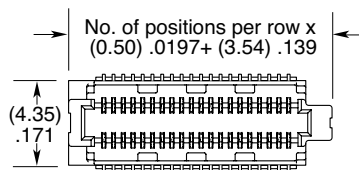

LEAD STYLE	A	B
-3.00	(2.85) .112	(3.50) .138
-3.50	(3.35) .132	(4.00) .157

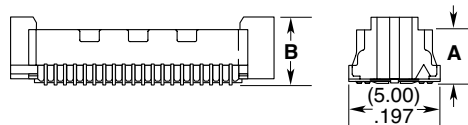

MATED HEIGHT *

ST5 LEAD STYLE	SS5 LEAD STYLE	
	-3.00	-3.50
-1.00	(4.00 mm) .157"	(4.50 mm) .177"
-1.50	(4.50 mm) .177"	(5.00 mm) .197"

*Processing conditions will affect mated height.

ST5	NO. OF POSITIONS	LEAD STYLE	PLATING OPTION	D	P	"X"R
-----	------------------	------------	----------------	---	---	------

-10, -15, -20,
-30, -40, -50,
-60, -70, -80
(Per Row)

-1.00
= 1.00 mm
-1.50
= 1.50 mm

-L
= 10 μ"
(0.25 μm)
Gold on contact,
Matte Tin on tail

(Required in callout)

-P
= Pick &
Place Pad

(Required in callout)

-TR
= Tape & Reel

-FR
= Full Reel
Tape & Reel
(must order max.
quantity per reel;
contact Samtec for
quantity breaks)

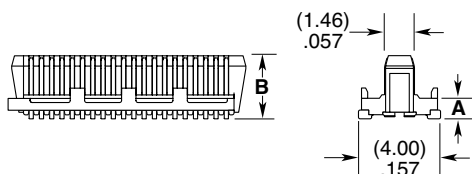
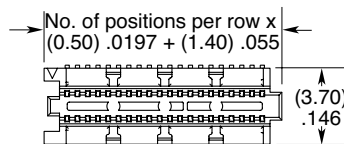

LEAD STYLE	A	B
-1.00	(1.00) .039	(3.08) .121
-1.50	(1.50) .059	(3.58) .141

HIGH-SPEED EDGE CARD SYSTEMS

SPEEDS TO 64 Gbps • RUGGED EDGE RATE® CONTACTS • VARIETY OF OPTIONS

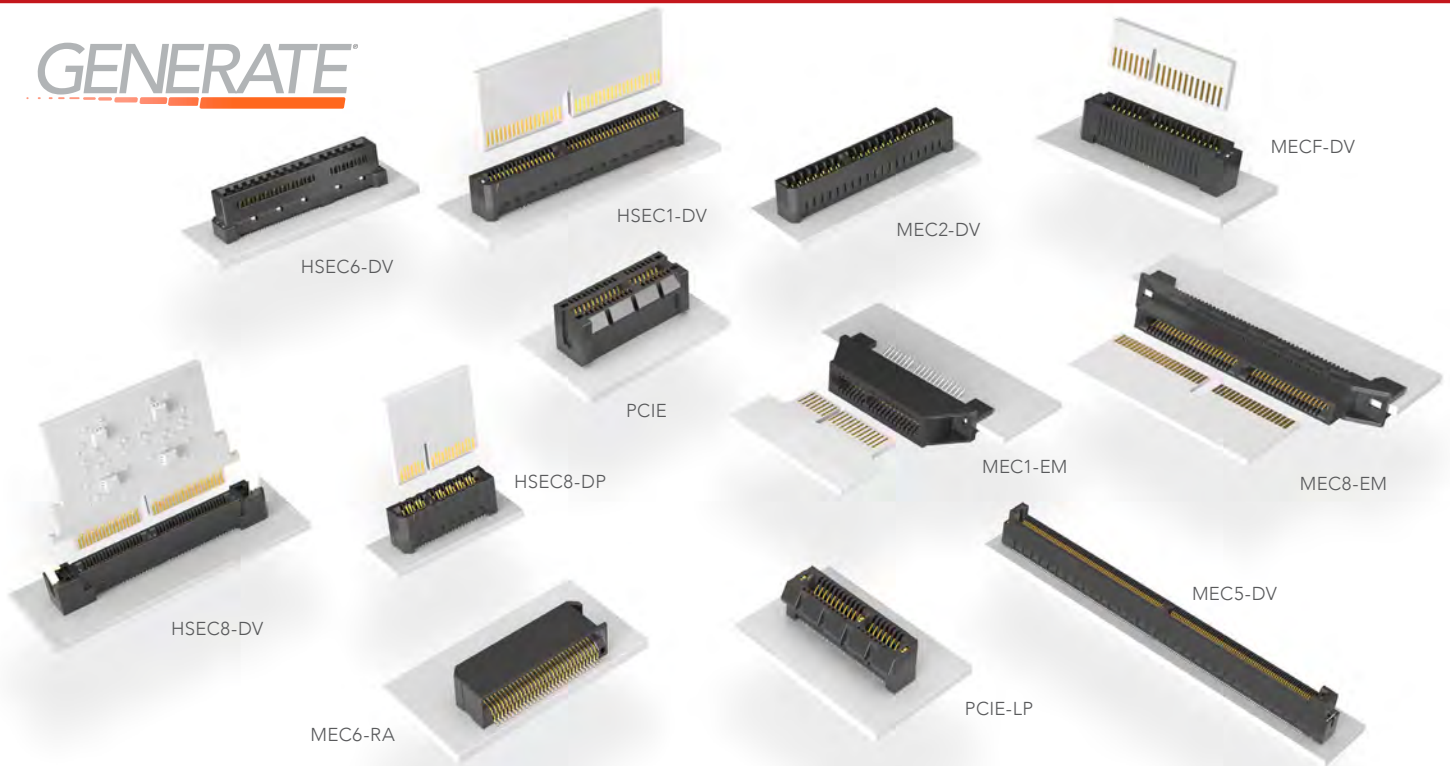

62-69

HIGH-SPEED EDGE CARD INTERCONNECTS

0.60 mm Pitch Generate® Socket (HSEC6)	63
0.80 mm Pitch Generate® Rugged Edge Card Socket (HSEC8)	64
0.80 mm Pitch Generate® Socket (HSEC8)	65-68
1.00 mm Pitch Generate® Socket (HSEC1)	69

70-77

MICRO/MINI EDGE CARD INTERCONNECTS

0.50 mm Pitch Micro Socket (MEC5)	71
0.635 mm Pitch Micro Socket (MEC6)	72
0.80 mm Pitch Micro Edge Socket (MEC8)	73-74
1.00 mm Pitch Mini Edge Card Socket (MEC1)	75-76
1.27 mm Pitch Mini Edge Card Socket (MECF)	77
2.00 mm Pitch Mini Edge Card Socket (MEC2)	77

78-80

PCI EXPRESS® INTERCONNECTS

PCI Express® & Low Profile PCI Express® Sockets (PCIE)	79
PCI Express® 4.0 & 5.0 Sockets (PCIE-G4 & PCIE-G5)	80

GENERATE[®]

HIGH-SPEED EDGE CARD SYSTEMS

0.60 mm, 0.80 mm and 1.00 mm PITCH



**EDGE
RATE[®]**
CONTACT

FEATURES & BENEFITS

- Maximum Design Flexibility
- Up to 64 Gbps PAM4 performance
- PCI Express[®] 3.0, 4.0, 5.0 and 6.0
- Edge Rate[®] contacts optimized for signal integrity performance and high-cycle life
- Up to 200 positions available
- Vertical, right-angle, edge mount, pass-through orientations
- Power/signal combo, press-fit tails, rugged weld tabs, locks and latches
- Mating cable assemblies available

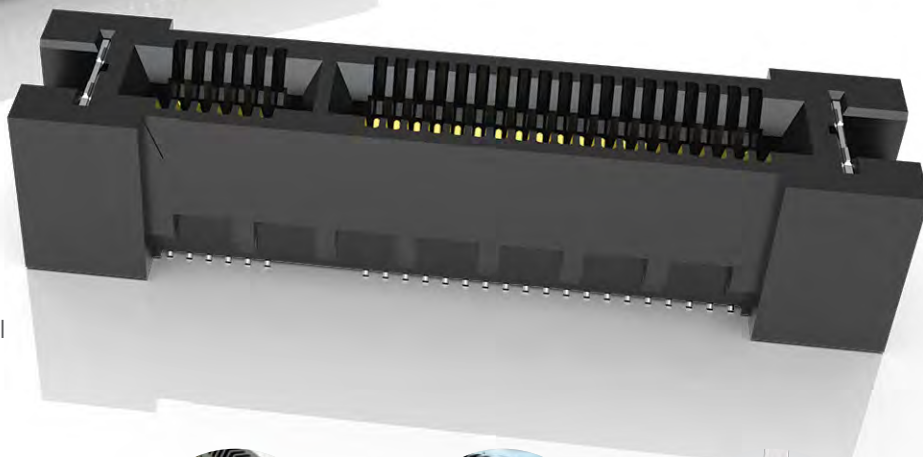

Rugged tucked beam technology (HTEC8)



Differential pair for increased speed (HSEC8-DP)



Custom designs allow for misalignment in the X-Y axes (HSEC1)

The PCI Express[®] design marks are registered trademarks and/or service marks of PCI-SIG.

KEY SPECIFICATIONS

SERIES	PITCH	TOTAL POSITIONS	INSULATOR MATERIAL	CONTACT MATERIAL	OPERATING TEMP RANGE	CURRENT RATING	VOLTAGE RATING	LEAD-FREE SOLDERABLE
HSEC6	0.60 mm	56-168	Black LCP	Copper Alloy	-55 °C to +125 °C	1.9 A (2 pins)	240 VAC/339 VDC	Yes
HTEC8	0.80 mm	20-200	Black LCP	Copper Alloy	-55 °C to +125 °C	3.0 A (2 pins)	215 VAC/304 VDC	Yes
HSEC8-DV	0.80 mm	18-200	Black LCP	BeCu	-55 °C to +125 °C	2.8 A (2 pins)	240 VAC/339 VDC	Yes
HSEC8-RA	0.80 mm	18-120	Black LCP	BeCu	-55 °C to +125 °C	2.6 A (2 pins)	175 VAC/247 VDC	Yes
HSEC8-EM	0.80 mm	20-120	Black LCP	BeCu	-55 °C to +125 °C	2.8 A (2 pins)	240 VAC/339 VDC	Yes
HSEC8-PE	0.80 mm	20-40	Black LCP	BeCu	-55 °C to +125 °C	2.8 A (2 pins)	240 VAC/339 VDC	Yes
HSEC8-PV	0.80 mm	40-80	Black LCP	BeCu	-55 °C to +125 °C	3.2 A (2 pins)	215 VAC/304 VDC	Yes
HSEC8-DP	0.80 mm	16-112	Black LCP	BeCu	-55 °C to +125 °C	2.7 A (2 pins)	235 VAC/332 VDC	Yes
HSEC1	1.00 mm	20-140	Black LCP	Phosphor Bronze	-55 °C to +125 °C	2.2 A (2 pins)	215 VAC/304 VDC	Yes

(0.60 mm) .024" PITCH • VERTICAL EDGE CARD SOCKET

HSEC6	POSITIONS PER ROW	CARD THICKNESS	PLATING OPTION	DV	SHIELD OPTION	WT	"X"R
	-028, -042, -070, -084	-01 = (1.60 mm) .062" thick card	-S = 30 μ" (0.76 μm) Gold on contact area, Matte Tin on tail		Leave blank for no shield -S = Shield (not available with -084 positions)	Required for everything but shielded -028 positions -WT = Weld tab	-TR = Tape & Reel -FR = Full Reel Tape & Reel (must order max. quantity per reel; contact Samtec for quantity breaks)

HSEC6
Card Mates:
(1.60 mm)
.062" thick card

Cable Mates:
GC6



OTHER SOLUTIONS

0.60 mm Pitch Mating High-Speed Cable Assembly. See GC6 Series.

Right-angle 0.60 mm pitch High-Speed edge card. See www.samtec.com?HSEC6-RA

For a card to mate with an HSEC6 socket, visit www.samtec.com?H6RU

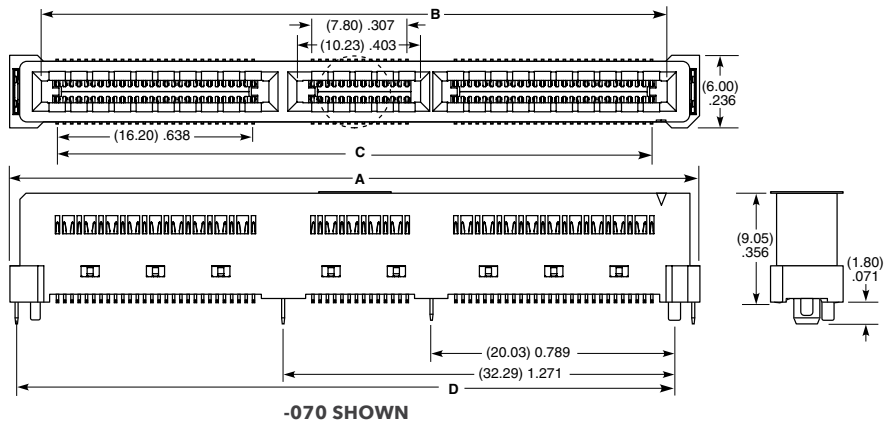

HIGH-SPEED PAIRS	SFF-TA-1002	POSITIONS PER ROW	A	B	C	D
x4, 8 DP's	1C	-028	(23.88) .940	(18.62) .733	(16.20) .638	(21.18) .834
x8, 16 DP's	2C	-042	(35.60) 1.402	(30.61) 1.205	(28.01) 1.103	(32.90) 1.295
	4C	-070	(57.02) 2.245	(51.72) 2.036	(49.12) 1.934	(54.32) 2.139
x16, 32 DP's	4C+	-084	(69.17) 2.723	(63.92) 2.516	(61.32) 2.414	(66.52) 2.619

STANDARDS

SFF-TA-1002
Visit www.samtec.com/standards for more information.

Note:
Polyimide film pick & place pad is standard.

Some sizes, styles and options are non-standard, non-returnable

View complete specifications at: samtec.com?HSEC6-DV

(0.80 mm) .0315" PITCH • RUGGED HIGH-SPEED EDGE CARD SOCKET

HTEC8	1	POSITIONS PER ROW	CARD THICKNESS	PLATING OPTION	DV	OPTION	OTHER OPTION	"X"R
		10, 20, 30, 40, 50, 60, 80, 100	-01 = (1.60 mm) .062" thick card -03 = (2.36 mm) .093" thick card	-L = 10 μ" (0.25 μm) Gold on contact area, Matte Tin on tail		Leave blank for no alignment pin -A = Alignment Pin -WT = Weld Tab (-A option required) -BL = Board Lock (-A option required) (Weld tab standard)	-K = (7.00 mm) .276" DIA Polyimide Pick & Place Pad	Leave blank for Tray Packaging -TR = Tape & Reel (10 thru 60 positions only) -FR = Full Reel Tape & Reel (must order max. quantity per reel; contact Samtec for quantity breaks) (10 thru 60 positions only)

HTEC8

Card Mates:
(1.60 mm) .062" thick card,
(2.36 mm) .093" thick card,
HSC8



POSITIONS PER ROW	C	D	E	F	G
40	(36.60) 1.440	(18.90) .744	(16.80) .661	(15.70) .618	(34.40) 1.354
50	(44.60) 1.756	(22.90) .902	(20.80) .819	(19.70) .776	(42.40) 1.669
60	(52.60) 2.071	(26.90) 1.059	(24.80) .976	(23.70) .933	(50.40) 1.984
80	(68.60) 2.701	(26.90) 1.059	(24.80) .976	(39.70) 1.563	(66.40) 2.614
100	(84.60) 3.331	(26.90) 1.059	(24.80) .976	(55.70) 2.193	(82.40) 3.244

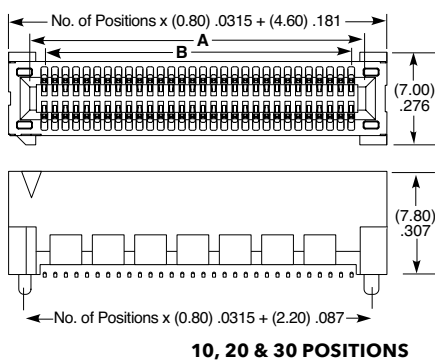
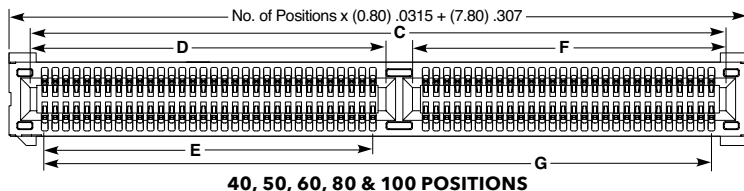

POSITIONS PER ROW	A	B
10	(9.40) .370	(7.20) .283
20	(17.40) .685	(15.20) 5.98
30	(25.40) 1.000	(23.20) .913

POSITIONS PER ROW	H
10	(14.90) .587
20	(22.90) .902
30	(30.90) 1.217
40	(42.10) 1.657
50	(50.10) 1.972
60	(58.10) 2.287
80	(74.10) 3.917
100	(90.10) 3.547

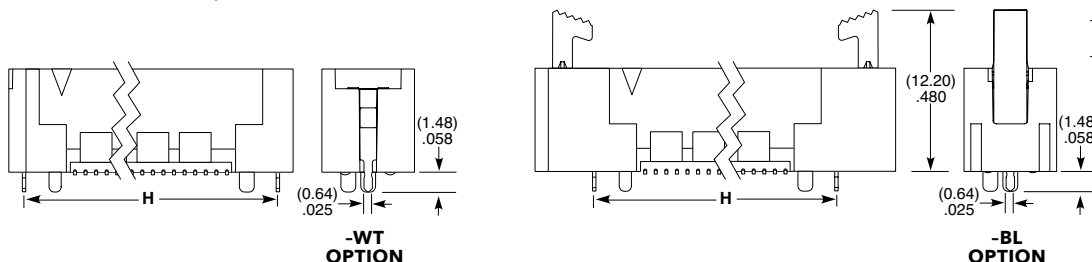

Note:
Some sizes, styles and options are non-standard, non-returnable.

View complete specifications at: samtec.com?HTEC8

(0.80 mm) .0315" PITCH • VERTICAL EDGE CARD SOCKET

HSEC8	1	POSITIONS PER ROW	CARD THICKNESS	PLATING OPTION	DV	A	OTHER OPTIONS	"X"R
		09, 10, 13, 20, 25, 30, 37, 40, 49, 50, 60, 70, 80, 100 (13, 25, 49 only available with -L or -L2 latching option; 09 only available with -L2 option; 37 only available with -L latching option)	-01 = (1.60 mm) .062" thick card -03 = (2.36 mm) .093" thick card	-L = 10 μm (0.25 μm) Gold on contact area, Matte Tin on tail			-K = Polyimide Pick & Place Pad -BL = Board Locks; -01 card only (Weld tab standard) -L = Latching Option; -01 card only (13, 25, 37, 49 only) (Weld tab standard) -L2 = ECDP Latching; -01 card only (09, 13, 25, 49 only) (For use with ECDP) (Weld tab standard) -WT = Weld tab	Leave blank for Tray Packaging -TR = Tape & Reel (09 - 70 only) -FR = Full Reel Tape & Reel (must order max. quantities per reel; contact Samtec for quantity breaks) (09-70 only)

HSEC8-DV

Card Mates:
(1.60 mm) .062" thick card,
(2.36 mm) .093" thick card,
HSC8

Cable Mates:
ECDP

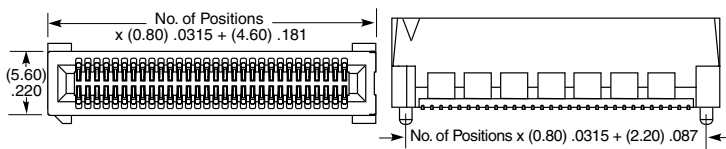
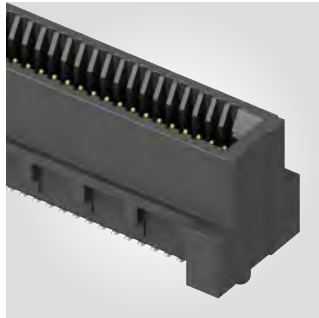

10, 20, & 30 POSITIONS

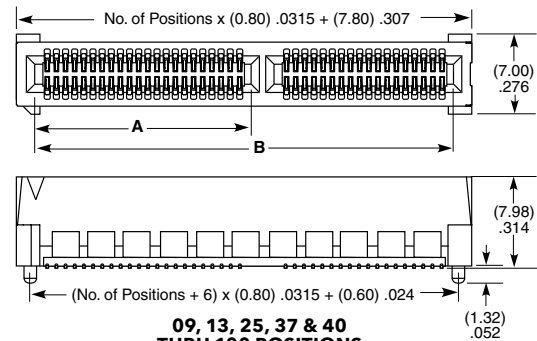

09, 13, 25, 37 & 40 THRU 100 POSITIONS

OTHER SOLUTIONS

For complete edge card system with cards and sockets, visit samtec.com?RU8

For a card to mate with an HSEC8 socket, visit samtec.com?HSC8



POSITIONS PER ROW	A	B	CABLE	CONNECTOR
09*†	(4.50) .177	(11.80) .465	ECDP-04	HSEC8-109-L2
13*†	(6.10) .240	(15.00) .591	ECDP-08	HSEC8-113-L2
25*†	(6.10) .240	(24.60) .969	ECDP-16	HSEC8-125-L2
37†	(18.10) .713	(34.20) 1.346	ECDP-32	HSEC8-149-L2
40	(18.90) .744	(36.60) 1.441		
49*†	(22.90) .902	(43.80) 1.724		
50	(22.90) .902	(44.60) 1.756		
60	(26.90) 1.059	(52.60) 2.071		
70†	(26.90) 1.059	(60.60) 2.386		
80†	(26.90) 1.059	(68.60) 2.701		
100†	(26.90) 1.059	(84.60) 3.331		

Positions where no dimensions are given do not have keying feature.

* Mates with ECDP Series

† Available with -01 Card Only

Note:
Some sizes, styles and options are non-standard, non-returnable.

View complete specifications at: samtec.com?HSEC8-DV

(0.80 mm) .0315" PITCH • RIGHT-ANGLE & EDGE MOUNT SOCKET

HSEC8 - **1** POSITIONS PER ROW - **CARD THICKNESS** - **PLATING OPTION** - **RA** - **OTHER OPTIONS** - **"X"R**

**09, 10, 13,
20, 25, 30,
40, 49, 50, 60**

-01
= (1.60 mm) .062"
thick card

-L
= 10 μ" (0.25 μm)
Gold on contact area,
Matte Tin on tail

-BL
= Board Locks
(09, 13, 25, 40,
49, 50, 60 only)

Leave blank for
Tray Packaging

-TR
= Tape & Reel

-L2
= ECDP Latching
(09, 13, 25, 49 only)

-FR
= Full Reel
Tape & Reel Packaging
(must order max.
quantity per reel;
contact Samtec for
quantity breaks)

HSEC8-RA

Card Mates:
(1.60 mm) .062"
thick card,
HSC8
Cable Mates:
ECDP



POSITIONS PER ROW	A	B	C
40	(43.80) 1.724	(18.90) .744	(36.60) 1.441
50	(51.80) 2.039	(22.90) .902	(44.60) 1.756
60	(59.80) 2.354	(26.90) 1.059	(52.60) 2.071
40-BL	(51.30) 2.020	(18.90) .744	(36.60) 1.441
50-BL	(59.30) 2.335	(22.90) .902	(44.60) 1.756
60-BL	(67.30) 2.650	(26.90) 1.059	(52.60) 2.071

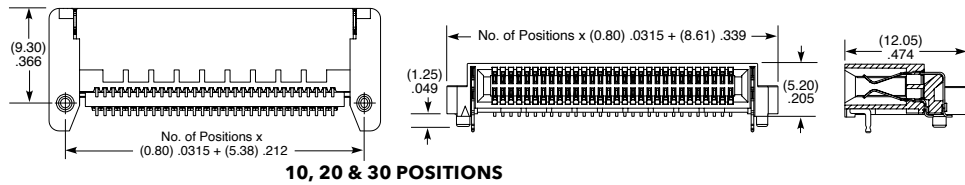
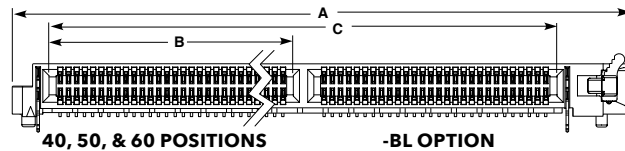

View complete specifications at: samtec.com?HSEC8-RA

HSEC8 - **1** POSITIONS PER ROW - **01** - **PLATING OPTION** - **D** - **EM2**

10, 20, 30, 40, 50, 60

-L
= 10 μ" (0.25 μm)
Gold on contact area,
Matte Tin on tail

-EM2
= (1.60 mm) .062"
thick PCB

HSEC8-EM

Card Mates:
(1.60 mm) .062"
thick card,
HSC8
Cable Mates:
ECDP

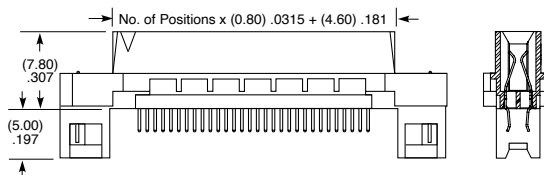
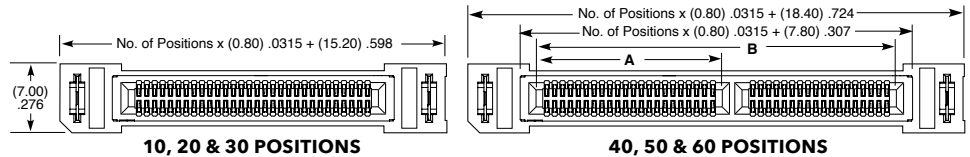

POSITIONS PER ROW	A	B
40	(18.90) .744	(36.60) 1.441
50	(22.90) .902	(44.60) 1.756
60	(26.90) 1.059	(52.60) 2.071

View complete specifications at: samtec.com?HSEC8-EM

Note:
Some sizes, styles and
options are non-standard,
non-returnable.

(0.80 mm) .0315" PITCH • PASS-THROUGH & POWER COMBO

HSEC8 - **1** POSITIONS PER ROW - **CARD THICKNESS** - **PLATING OPTION** - **DV** - **A** - **PE** - **OTHER OPTIONS** - **"X"R**

10, 13, 20

-01
= (1.60 mm) .062" thick card

-L
= 10 μ" (0.25 μm)
Gold on contact area,
Matte Tin on tail

-K
= (5.50 mm) .217" DIA
Polyimide
Film Pick &
Place Pad

Leave blank for Tray Packaging

-TR
=Tape & Reel Packaging

-FR
= Full Reel Tape & Reel Packaging
(Must order max. quantities per reel. Contact Samtec for parts per reel)

HSEC8-PE

Card Mates:
(1.60 mm) .062" thick card, HSC8

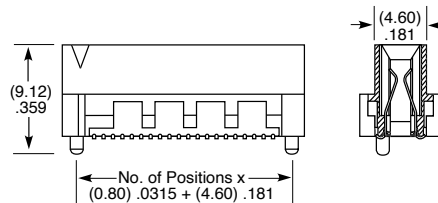
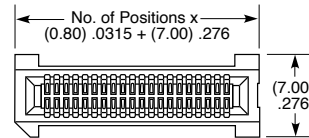

OTHER SOLUTIONS

1.00 mm High-Speed Micro Plane Socket.
View complete specifications at samtec.com?SAL1

View complete specifications at: samtec.com?HSEC8-DV

HSEC8 - **1** SIGNAL POSITIONS - **CARD THICKNESS** - **PLATING OPTION** - **PV** - **POWER POSITIONS** - **POWER TAIL** - **OTHER OPTION**

20, 30, 40
(Signal positions per row)

-01
= (1.60 mm) .062" thick card

-L
= 10 μ" (0.25 μm)
Gold on contact area,
Matte Tin on tail

-2, -4
(Total, 2 per power bank)

-1
= Use with (1.60 mm) .062" Thick PCB

-WT
= Weld Tab

-2
= Use with (2.36 mm) .093" Thick PCB

HSEC8-PV

Card Mates:
(1.60 mm) .062" thick card

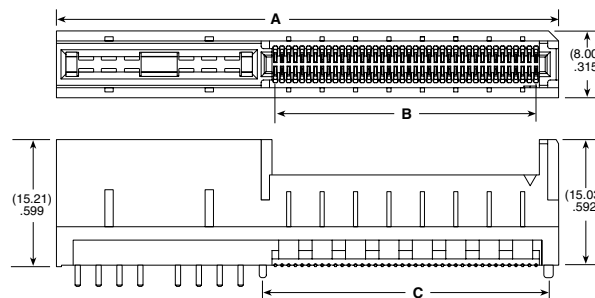

SIGNAL POSITIONS	POWER POSITIONS					
	A (-2)	B (-2)	C (-2)	A (-4)	B (-4)	C (-4)
20	(32.10) 1.264	(15.20) .598	(18.20) .717	(44.10) 1.736	(15.20) .598	(18.20) .717
30	(40.10) 1.579	(23.20) .913	(26.20) 1.031	(52.10) 2.051	(23.20) .913	(26.20) 1.031
40	(48.10) 1.894	(31.20) 1.228	(34.20) 1.346	(60.10) 2.366	(31.20) 1.228	(34.20) 1.346

POWER TAIL	D
-1	(2.35) .093
-2	(3.13) .123

Note:
Some sizes, styles and options are non-standard, non-returnable.

View complete specifications at: samtec.com?HSEC8-PV

0.80 mm (.0315") PITCH • DIFFERENTIAL PAIR EDGE CARD

HSEC8	1	NUMBER OF PAIRS	01	PLATING OPTION	DP	A	OPTION	K	"X"R
		08, 12, 16, 20, 32, 56 (Total Pairs)		-L = 10 μ" (0.25 μm) Gold on contact area, Matte Tin on tail			Leave blank for no weld tab -WT = Weld Tab	-K = (6.25 mm) .246" DIA Polyimide Film Pick & Place Pad	Leave blank for Tape & Reel -FR = Full Reel Tape & Reel (must order max. quantity per reel; contact Samtec for quantity breaks)

HSEC8-DP
Card Mates:
(1.60 mm) .062" thick card

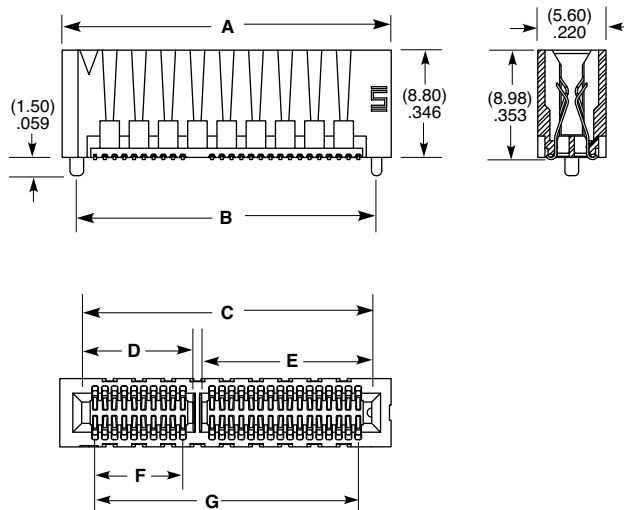

NUMBER OF PAIRS	A	B	C	D	E	F	G
08	(17.40) .685	(15.00) .591	(14.20) .559	(4.34) .171	(9.14) .360	(2.40) .094	(12.00) .472
12	(22.20) .874	(19.80) .780	(19.00) .748	(6.74) .265	(11.54) .454	(4.80) .189	(16.80) .661
16	(27.00) 1.063	(24.60) .969	(23.80) .937	(9.14) .360	(13.94) .549	(7.20) .283	(21.60) .850
20	(31.80) 1.252	(29.40) 1.157	(28.60) 1.126	(11.54) .454	(16.34) .643	(9.60) .378	(26.40) 1.039
32	(46.20) 1.819	(43.80) 1.724	(43.00) 1.693	(18.74) .738	(23.54) .927	(16.80) .661	(40.80) 1.606
56	(75.00) 2.953	(72.60) 2.858	(71.80) 2.827	(33.14) 1.305	(37.94) 1.494	(31.20) 1.228	(69.60) 2.740

Note:
Some sizes, styles and options are non-standard, non-returnable.

View complete specifications at: samtec.com?HSEC8-DP

1.00 mm (.0394") PITCH • VERTICAL HIGH-SPEED EDGE CARD

HSEC1	POSITIONS PER ROW	CARD THICKNESS	PLATING OPTION	DV	OPTION	OTHER OPTION	"X"R
	-010, -020, -030, -040, -050, -060, -070	-01 =(1.60 mm) .062" thick card	-F = Gold flash on contact, Matte Tin on tail -L = 10 μ" (0.25 μm) Gold on contact area, Matte Tin on tail		-A or -WT required in callout -A =Alignment Pin (Not available with -WT) -WT =Weld tab (Not available with -A)	-K =(7.01 mm) .276" DIA Polyimide Film Pick & Place Pad	-TR or -FR required for 10-60 positions. Leave blank for 70 positions. -TR =Tape & Reel -FR = Full Reel Tape & Reel (must order max. quantity per reel; contact Samtec for quantity breaks)

HSEC1-DV
Card Mates:
(1.60 mm) .062"
thick card

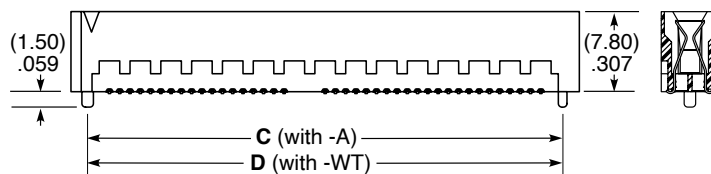
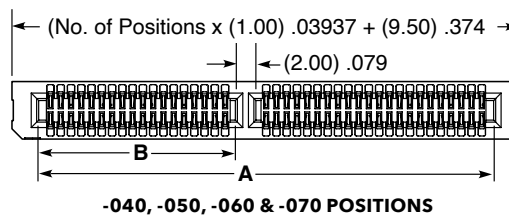
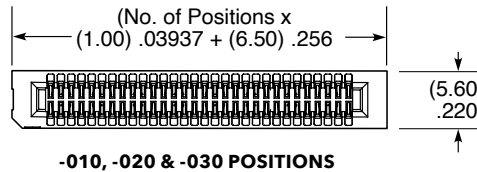
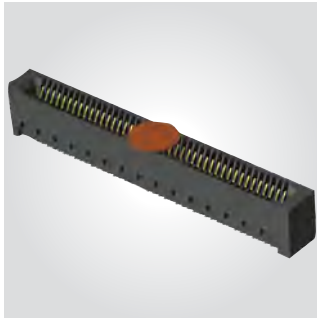

POSITIONS PER ROW	A	B	C (with -A)	D (with -WT)
-010	(11.30) .445	N/A	(13.25) .522	(14.50) .571
-020	(21.30) .839	N/A	(23.25) .915	(24.50) .965
-030	(31.30) 1.232	N/A	(33.25) 1.309	(34.50) 1.358
-040	(44.30) 1.744	(19.15) .754	(46.25) 1.821	(47.50) 1.870
-050	(54.30) 2.138	(24.15) .951	(56.25) 2.215	(57.50) 2.264
-060	(64.30) 2.531	(29.15) 1.148	(66.25) 2.608	(67.50) 2.657
-070	(74.30) 2.925	(34.15) 1.344	(76.25) 3.002	(77.50) 3.051

Note:
Some sizes, styles and
options are non-standard,
non-returnable.

View complete specifications at: samtec.com?HSEC1-DV

MICRO EDGE CARD SYSTEMS

0.50 mm, 0.635 mm, 0.80 mm, 1.00 mm, 1.27 mm, 2.00 mm PITCH

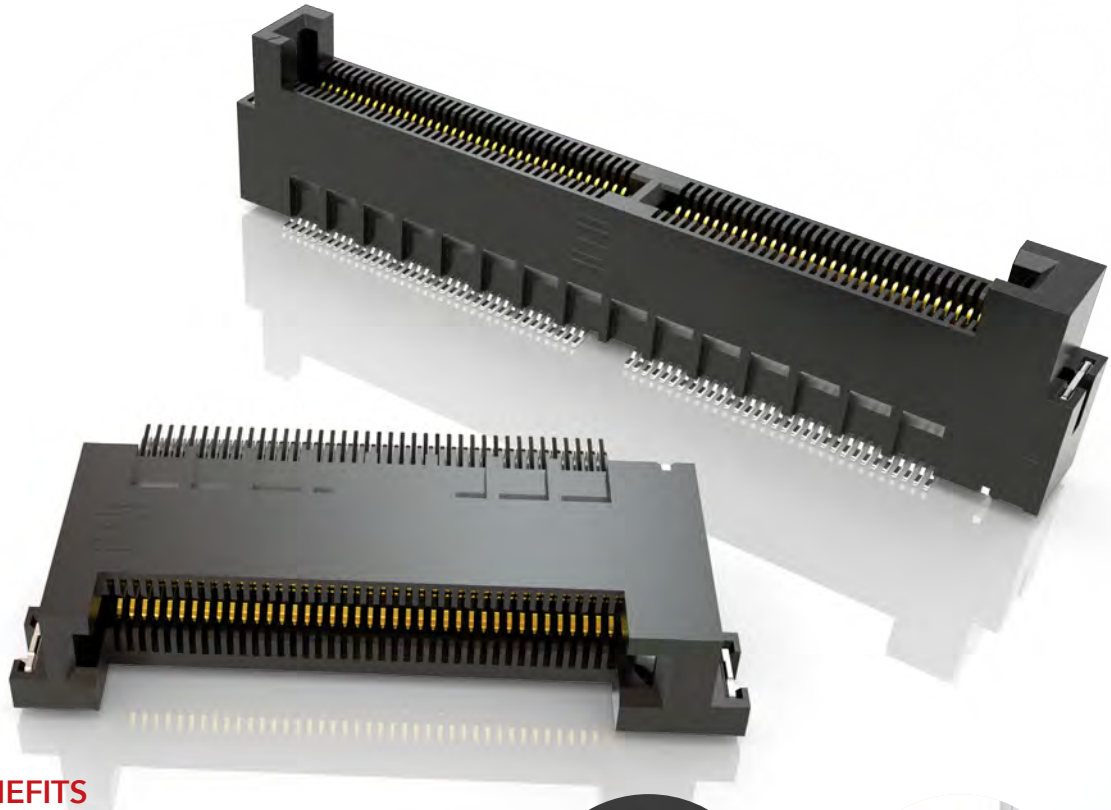

FEATURES & BENEFITS

- Up to 56 Gbps PAM4
- PCI Express® 4.0 (MEC5 Series)
- Solutions for (1.60 mm) .062" and (2.36 mm) .093" thick cards
- Choice of pitch: 0.50 mm, 0.635 mm, 0.80 mm, 1.00 mm, 1.27 mm, 2.00 mm
- Vertical, right-angle and edge mount orientations
- Available in surface mount and through-hole



Staggered press-fit tails
(MEC8-VP)

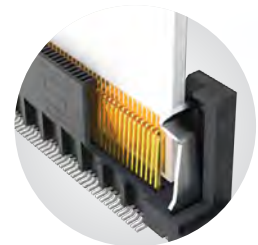

Justification beam ensures
card and body are flush
(MEC5)

KEY SPECIFICATIONS

SERIES	PITCH	TOTAL POSITIONS	INSULATOR MATERIAL	CONTACT MATERIAL	OPERATING TEMP RANGE	CURRENT RATING	VOLTAGE RATING	LEAD-FREE SOLDERABLE
MEC5	0.50 mm	60-200	Black LCP	Phosphor Bronze	-55 °C to +125 °C	1.5 A (2 pins)	125 VAC/177 VDC	Yes
MEC6	0.635 mm	20-140	Black LCP	Phosphor Bronze	-55 °C to +125 °C	2.4 A (2 pins)	185 VAC/262 VDC	Yes
MEC8	0.80 mm	20-140	Black LCP	Phosphor Bronze	-55 °C to +125 °C	2.3 A (2 pins)	180 VAC/255 VDC	Yes
MEC1	1.00 mm	20-140	Black LCP	BeCu	-55 °C to +125 °C	2.2 A (2 pins)	250 VAC/354 VDC	Yes
MECF	1.27 mm	10-100	Black/Natural LCP	BeCu	-55 °C to +125 °C	3.5 A (2 pins)	280 VAC/396 VDC	Yes
MEC2	2.00 mm	10-100	Black/Natural LCP	BeCu	-55 °C to +125 °C	3.5 A (2 pins)	280 VAC/396 VDC	Yes

PCI-SIG®, PCI Express® and the PCIe® design marks are registered trademarks and/or service marks of PCI-SIG.

(0.50 mm) .0197" PITCH • MICRO EDGE CARD SOCKET

MEC5	POSITIONS PER ROW	01	PLATING OPTION	TAIL OPTION	WELD TAB OPTION	OTHER OPTION	"X"R
	-030, -040, -050, -060, -070, -080 (-RA & -DV) -090, -100 (-DV only)		-L =10 μ" (0.25 μm) Gold on contact, Matte Tin on tail	-DV Vertical -RA Right-angle	-W1 = Weld Tab Through-hole (Required for -DV option) -W2 = Weld Tab Surface Mount (Not available for -DV)	-K = Polyimide Pick & Place Pad (Required for -DV) (Not available in -RA)	-TR = Tape & Reel -FR = Full Reel Tape & Reel (must order max. quantity per reel; contact Samtec for quantity breaks)

MEC5-DV

Card Mates:
(1.60 mm) .062"
thick card with
standard board
tolerance

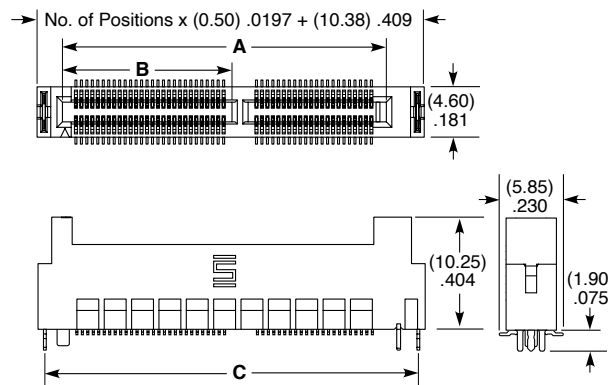
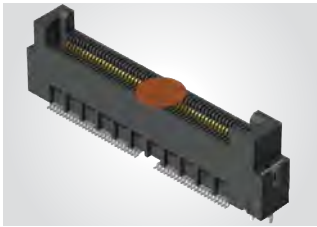

POSITIONS PER ROW	A	B	C
-030	(17.10) .673	N/A	(21.63) .852
-040	(22.10) .870	N/A	(26.63) 1.048
-050	(29.60) 1.165	(15.48) .609	(34.13) 1.344
-060	(34.60) 1.362	(17.98) .708	(39.13) 1.541
-070	(39.60) 1.559	(20.48) .806	(44.13) 1.737
-080	(44.60) 1.756	(22.98) .905	(49.13) 1.934
-090	(49.60) 1.953	(25.48) 1.003	(54.13) 2.131
-100	(54.60) 2.150	(27.98) 1.102	(59.13) 2.328

Note: Polarization rib is not present on -030 & -040 positions

View complete specifications at: samtec.com?MEC5-DV

MEC5-RA

Card Mates:
(1.60 mm) .062"
thick card with
standard board
tolerance

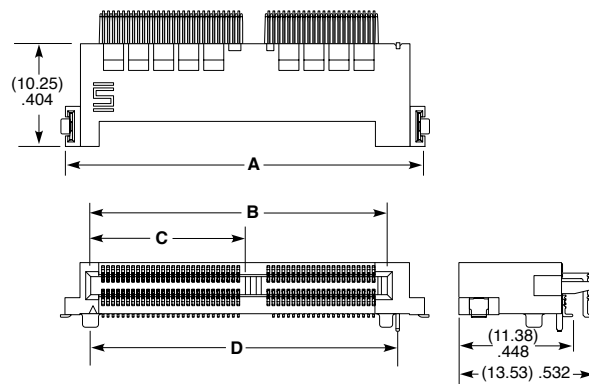

POSITIONS PER ROW	A	B	C	D
-30	(23.38) .920	(17.10) .673	N/A	(18.16) .715
-40	(28.38) 1.117	(22.10) .870	N/A	(23.16) .912
-50	(35.88) 1.413	(29.60) 1.165	(15.44) .608	(30.66) 1.207
-60	(40.88) 1.609	(34.60) 1.362	(17.94) .706	(35.66) 1.404
-70	(45.88) 1.806	(39.60) 1.559	(20.44) .805	(40.66) 1.601
-80	(50.88) 2.003	(44.60) 1.756	(22.94) .903	(45.66) 1.798

Note: Polarization rib is not present on -030 & -040 positions

View complete specifications at: samtec.com?MEC5-RA

Note:
Some sizes, styles and
options are non-standard,
non-returnable.

(0.635 mm) .025" PITCH • VERTICAL AND RIGHT-ANGLE EDGE CARD SOCKET

MEC6 - 1 POSITIONS PER ROW - 02 - PLATING OPTION - DV - A - OPTION - "X"R

10, 20, 30, 40,
50, 60, 70

-L
= 10 μ" (0.25 μm)
Gold on contact,
Matte Tin on tail

-K
= (5.50 mm) 2.17" DIA
Polyimide Pick
& Place Pad

Leave blank
for Tray Packaging

-TR
= Tape & Reel

-FR
= Full Reel
Tape & Reel
(must order max.
quantity per reel;
contact Samtec for
quantity breaks)

MEC6-DV

Card Mates:
(1.60 mm) .062"
thick card

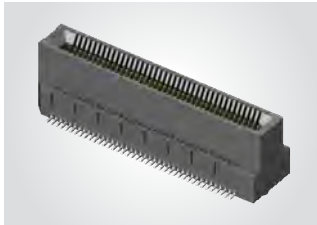

POSITIONS PER ROW	A	B
50	(21.06) .829	(36.49) 1.437
60	(24.87) .979	(42.84) 1.687
70	(28.68) 1.129	(49.19) 1.937

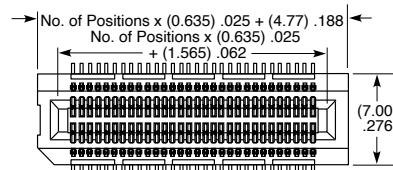

10, 20, 30 & 40 POSITIONS

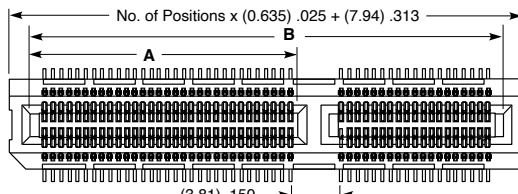

50, 60 & 70 POSITIONS

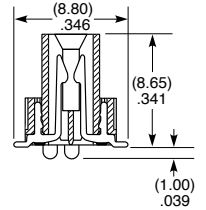
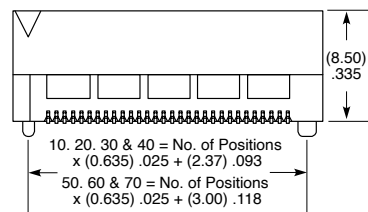

View complete specifications at: samtec.com?MEC6-DV

MEC6 - 1 POSITIONS PER ROW - 02 - PLATING OPTION - D - TAIL - OPTIONS

10, 20, 30,
40, 50

-L
= 10 μ" (0.25 μm)
Gold on contact,
Matte Tin on tail

-RA1
= Right-angle

-TR
= Tape & Reel

-FR
= Full Reel Tape & Reel
(must order max. quantity
per reel; contact Samtec
for quantity breaks)

MEC6-RA

Card Mates:
(1.60 mm) .062"
thick card

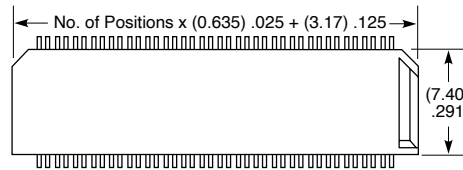
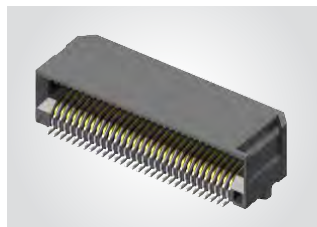

10, 20, 30 & 40 POSITIONS

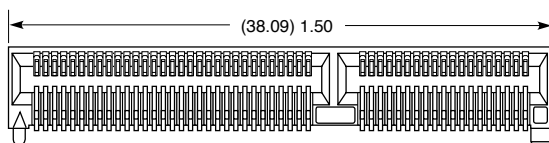

50 POSITIONS

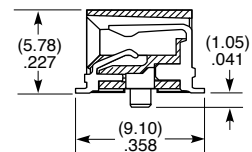

Note:
Some sizes, styles and
options are non-standard,
non-returnable.

View complete specifications at: samtec.com?MEC6-RA

(0.80 mm) .0315" PITCH • VERTICAL AND PRESS-FIT EDGE CARD SOCKET

MEC8 - **1** POSITIONS PER ROW - **02** PLATING OPTION - **DV** OTHER OPTIONS - **"X"R**

10, 20, 30, 40,
50, 60, 70

-L
= 10 μ" (0.25 μm)
Gold on contact,
Matte Tin on tail

-A
= Alignment Pin

-K
= (5.50 mm) 2.17" DIA
Polyimide Pick
& Place Pad

Leave blank for
Tray Packaging

-TR
= Tape & Reel

-FR
= Full Reel
Tape & Reel
(must order max.
quantity per reel;
contact Samtec for
quantity breaks)

MEC8-DV

Card Mates:
(1.60 mm) .062"
thick card

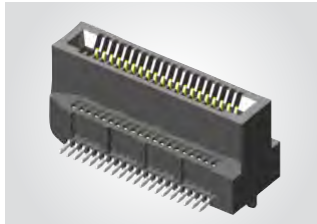

POSITIONS PER ROW	A	B
40	(18.90) .744	(36.60) 1.441
50	(22.90) .902	(44.60) 1.756
60	(26.90) 1.059	(52.60) 2.071
70	(30.90) 1.217	(60.60) 2.386

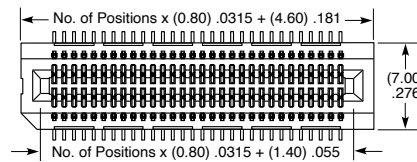

25
Gbps

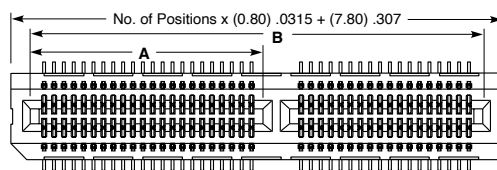

40, 50, 60 & 70 POSITIONS

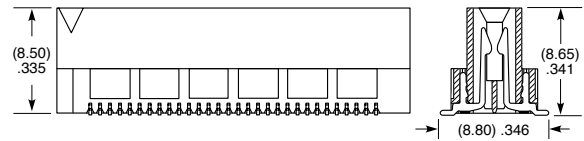

10, 20, & 30 POSITIONS

View complete specifications at: samtec.com?MEC8-DV

MEC8 - **1** POSITIONS PER ROW - **CARD THICKNESS** - **PLATING OPTION** - **TAIL**

10, 20, 30, 40

-02
= (1.60 mm) .062"
thick card

-L
= 10 μ" (0.25 μm) Gold on contact,
Matte Tin on tail

-VP
= Press-fit

MEC8-VP

Card Mates:
(1.60 mm) .062"
thick card

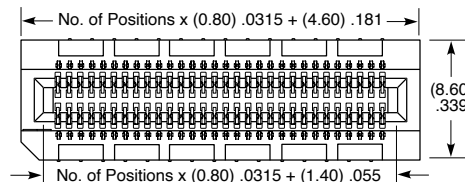
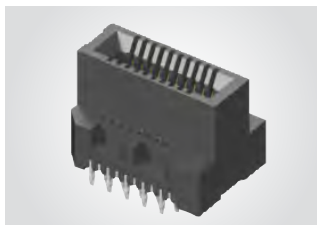

10, 20 & 30 POSITIONS

14
Gbps

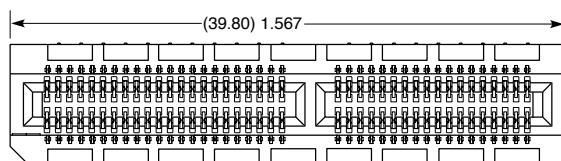

40 POSITIONS

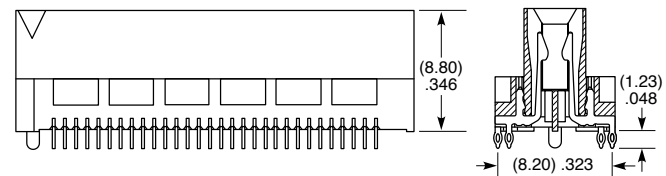

Note:
Some sizes, styles and
options are non-standard,
non-returnable.

View complete specifications at: samtec.com?MEC8-VP

(0.80 mm) .0315" PITCH • RIGHT-ANGLE/EDGE MOUNT EDGE CARD SOCKET

MEC8 - **1** POSITIONS PER ROW - **02** - **PLATING OPTION** - **D** - **RA1** - **"X"R**

10, 13, 20,
25, 30, 37, 40,
49, 50

-L
= 10 μm (0.25 μm)
Gold on contact,
Matte Tin on tail

Leave blank
for Tray Packaging

-TR
= Tape & Reel

-FR
= Full Reel
Tape & Reel
(must order max.
quantity per reel;
contact Samtec for
quantity breaks)

MEC8-RA

Card Mates:
(1.60 mm) .062"
thick card

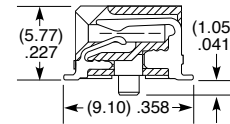
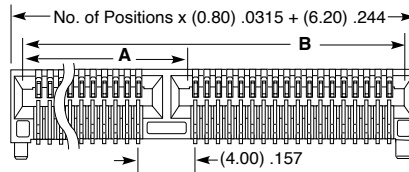
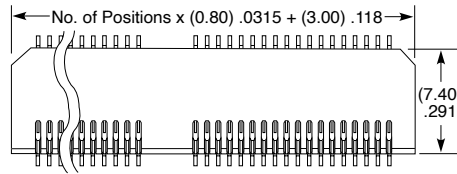
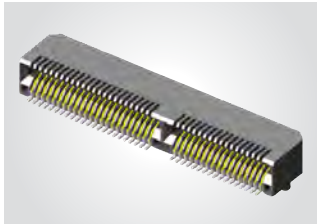

POSITIONS PER ROW	A	B
13	(6.10) .240	(15.00) .591
25		(24.60) .969
37	(18.10) .713	(34.20) 1.346
40	(18.90) .744	(36.60) 1.441
49		(43.80) 1.724
50	(22.90) .902	(44.60) 1.756

View complete specifications at: samtec.com?MEC8-RA

MEC8 - **1** POSITIONS PER ROW - **02** - **PLATING OPTION** - **D** - **EM2**

10, 20, 30, 40, 50, 60, 70

-L
= 10 μm (0.25 μm) Gold on contact,
Matte Tin on tail

MEC8-EM

Card Mates:
(1.60 mm) .062"
thick card

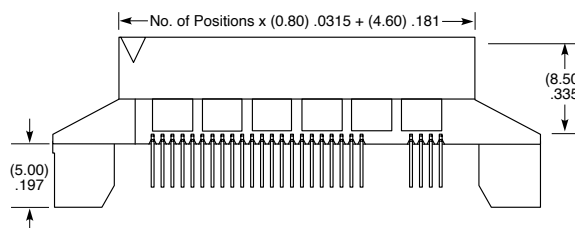
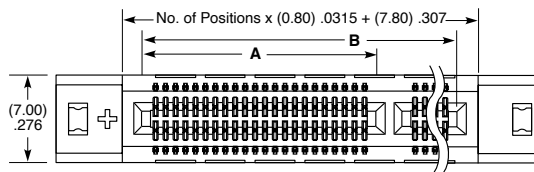
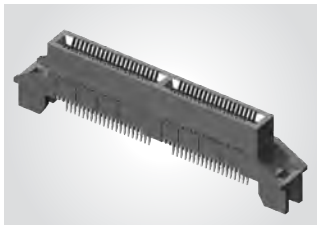

POSITIONS PER ROW	A	B
40	(18.90) .744	(36.60) 1.441
50	(22.90) .902	(44.60) 1.756
60	(26.90) 1.059	(52.60) 2.071
70	(30.90) 1.217	(60.60) 2.386

Note:
Some sizes, styles and
options are non-standard,
non-returnable.

View complete specifications at: samtec.com?MEC8-EM

(1.00 mm) .0394" PITCH • MINI EDGE CARD SOCKET

MEC1	1	POSITIONS PER ROW	02	PLATING OPTION	D	NP	OTHER OPTIONS	"X"R
		05, 08, 10, 20, 30, 40, 50, 60, 70		-F = Gold flash on contact, Matte Tin on tail -L = 10 μ" (0.25 μm) Gold on contact, Matte Tin on tail		Leave blank for polarization -NP =No Polarization (05, 08, 20 & 30 positions only)	-A = Alignment Pin metal or plastic at Samtec discretion -K = (7.87 mm) .310" DIA Polyimide film Pick & Place Pad	Leave blank for Tube Packaging -TR =Tape & Reel (05-60 only) -FR = Full Reel Tape & Reel (must order max. quantity per reel; contact Samtec for quantity breaks) (05-60 only)

MEC1

Card Mates:
(1.60 mm) .062" thick card

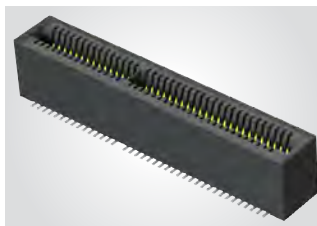

POSITIONS PER ROW	POLARIZED POSITIONS (No Contact)
05	3, 4
08	5, 6
10	13, 14,
20	15, 16,
30	21, 22
40	31, 32
50	41, 42
60	31, 32, 63 & 64
70	53, 54, 115 & 116

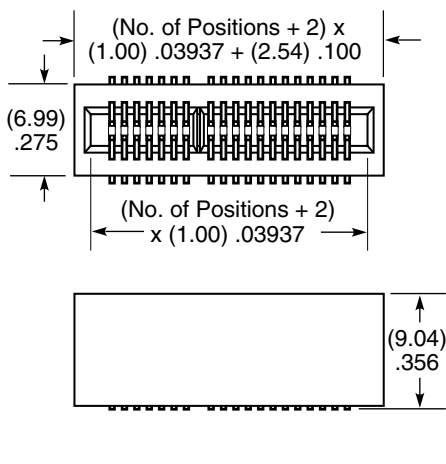

Note:
Some sizes, styles and options are non-standard, non-returnable.

View complete specifications at: samtec.com?MEC1

(1.00 mm) .0394" PITCH • RIGHT-ANGLE/EDGE MOUNT EDGE CARD SOCKET

MEC1	1	POSITIONS PER ROW	02	PLATING OPTION	D	RA1	NP	SL	"X"R
		05, 08, 20, 30, 40, 50, 60, 70		-F = Gold Flash on contact, Matte Tin on tail -L = 10 μ" (0.25 μm) Gold on contact, Matte Tin on tail			Leave blank for polarization -NP = No Polarization (8 thru 30 positions only)		Leave blank for Tube Packaging -TR = Tape & Reel (not available with 70 positions) -FR = Full Reel Tape & Reel (must order max. quantity per reel; contact Samtec for quantity breaks) (not available with 70 positions)

MEC1-RA

Card Mates:
(1.60 mm) .062" thick card

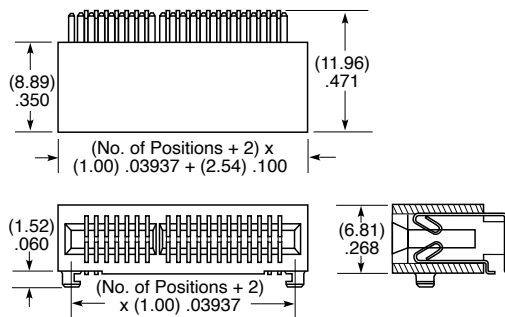
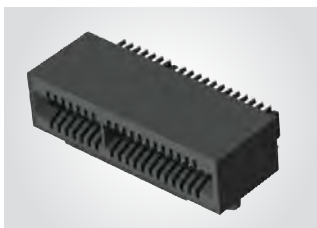

POSITIONS PER ROW	POLARIZED POSITIONS (No Contact)
05	3, 4
08	5, 6
20	15, 16
30	21, 22
40	31, 32
50	41, 42
60	31, 32, 63 & 64
70	53, 54, 115 & 116

View complete specifications at: samtec.com?MEC1-RA

MEC1	1	POSITIONS PER ROW	02	PLATING OPTION	D	EM2	NP	"X"R
		05, 08, 20, 30, 40, 50, 60, 70		-F = Gold Flash on contact, Matte Tin on tail -L = 10 μ" (0.25 μm) Gold on contact, Matte Tin on tail			Leave blank for polarization -NP = No Polarization (8 thru 30 positions only)	Leave blank for Tray Packaging -TR = Tape & Reel (not available with 60 & 70 positions) -FR = Full Reel Tape & Reel (must order max. quantity per reel; contact Samtec for quantity breaks) (not available with 60 & 70 positions)

MEC1-EM

Card Mates:
(1.60 mm) .062" thick card

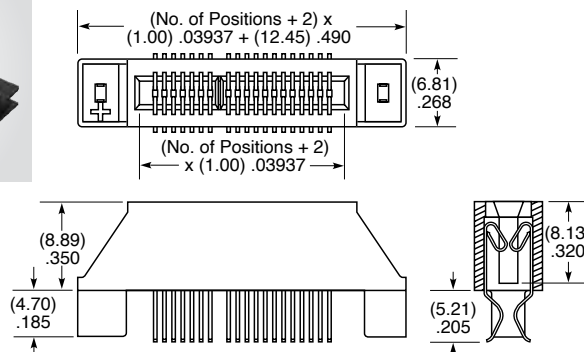

POSITIONS PER ROW	POLARIZED POSITIONS (No Contact)
05	3, 4
08	5, 6
20	15, 16
30	21, 22
40	31, 32
50	41, 42
60	31, 32, 63 & 64
70	53, 54, 115 & 116

View complete specifications at: samtec.com?MEC1-EM

Note:
Some sizes, styles and options are non-standard, non-returnable.

(1.27 mm) .050" PITCH • MINI EDGE CARD SOCKET

MECF	POSITIONS PER ROW	CARD THICKNESS	PLATING OPTION	DV	OPTION	"X"R
	-05, -08, -20, -30, -40, -50	-01 = (1.60 mm) .062" thick card -02 = (2.36 mm) .093" thick card	-L =10 μm (0.25 μm) Gold on contact, Matte Tin on tail		-WT = Weld Tabs (Standard on -02 card thickness, optional on -01 card thickness) -K Polyimide film pick & place pad (-"X"R only)	Leave blank for Tube Packaging -TR = Tape & Reel -FR = Full Reel Tape & Reel (must order max. quantity per reel; contact Samtec for quantity breaks)

MECF

Card Mates:
(1.60 mm) .062"
thick card
(2.36 mm) .093"
thick card

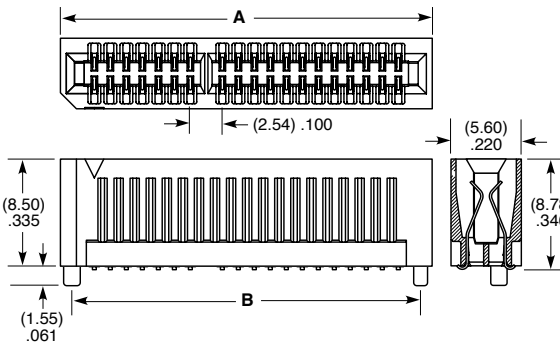

POSITIONS PER ROW	A	B
-05	(10.46) .412	(8.64) .340
-08	(14.27) .562	(12.45) .490
-20	(29.51) 1.162	(27.69) 1.090
-30	(42.21) 1.662	(40.39) 1.590
-40	(54.91) 2.162	(53.09) 2.090
-50	(67.61) 2.662	(65.79) 2.590

POSITIONS PER ROW	POLARIZED POSITIONS (No Contact)
-05	3, 4
-08	5, 6
-20	15, 16
-30	21, 22
-40	31, 32
-50	41, 42

View complete specifications at: samtec.com?MECF-DV

(2.00 mm) .0787" PITCH • MINI EDGE CARD SOCKET

MEC2	POSITIONS PER ROW	CARD THICKNESS	PLATING OPTION	TAIL OPTION	OPTION	"X"R
	-05, -08, -20, -30, -40, -50	-01 = (1.60 mm) .062" thick card -02 = (2.36 mm) .093" thick card (-DV option only)	-L =10 μm (0.25 μm) Gold on contact, Matte Tin on tail	-DV Vertical Surface Mount -TH1 Through-hole	-WT = Weld Tabs (standard on -02 card, optional on -01 card) -K = Polyimide film pick & place pad (-"X"R & -DV only)	Leave blank for Tube Packaging -TR = Tape & Reel (05 thru 30 positions only) (Not available with -TH1) -FR = Full Reel Tape & Reel (must order max. quantity per reel; contact Samtec for quantity breaks) (05 thru 30 positions only) (Not available with -TH1)

MEC2-DV

Card Mates:
(1.60 mm) .062"
thick card
(2.36 mm) .093"
thick card



MEC2-TH

Card Mates:
(1.60 mm) .062"
thick card

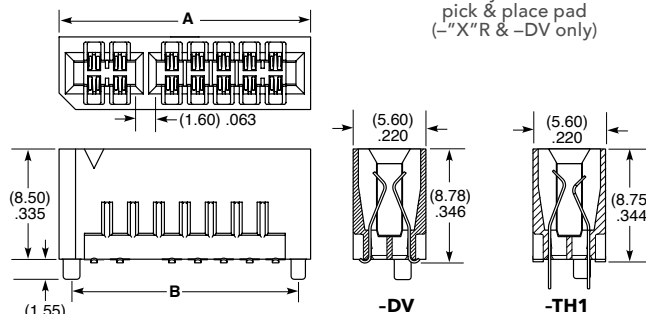

POSITIONS PER ROW	A	B	POSITIONS PER ROW	POLARIZED POSITIONS (No Contact)
-05	(13.40) .528	(11.50) .453	-05	3, 4
-08	(19.40) .764	(17.50) .689	-08	5, 6
-20	(43.40) 1.709	(41.50) 1.634	-20	15, 16
-30	(63.40) 2.496	(61.50) 2.421	-30	21, 22
-40	(83.40) 3.283	(81.50) 3.209	-40	31, 32
-50	(103.40) 4.071	(101.50) 3.996	-50	41, 42

Note:
Some sizes, styles and
options are non-standard,
non-returnable.

View complete specifications at: samtec.com?MEC2-DV & samtec.com?MEC2-TH

PCI EXPRESS® EDGE CARD SOCKETS

(1.00 mm) .0394" PITCH

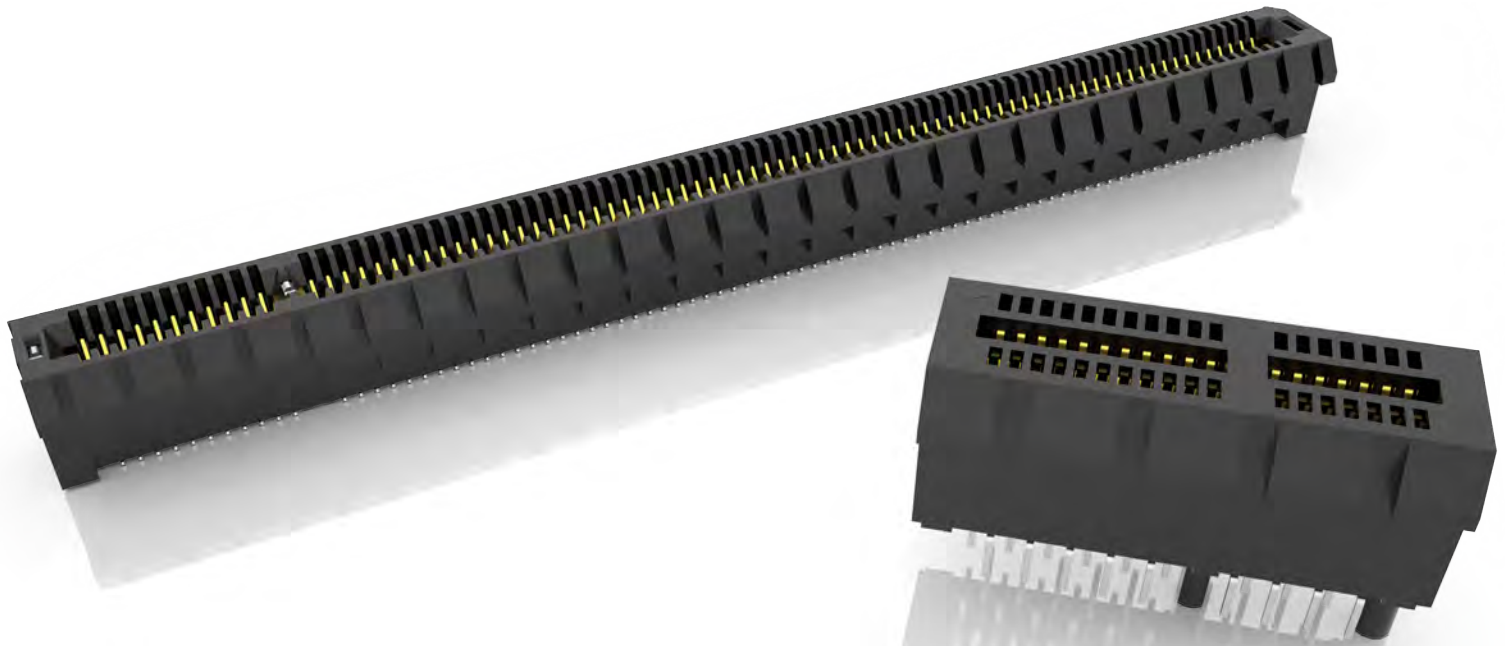

FEATURES & BENEFITS

- 1.00 mm pitch
- Supports 1, 4, 8 and 16 PCI Express® links
- PCIe® 3.0 Solution (PCI-E)
- PCIe® 4.0 Solution with low profile design for space savings (PCI-E-LP)
- PCIe® 4.0 with slim body design (PCI-E-G4)
- PCIe® 5.0/6.0 Solution with differential pair signaling (PCI-E-G5)
- Vertical, right-angle and edge mount
- Mates with .062" (1.60 mm) thick cards
- Alignment pin and weld tab options

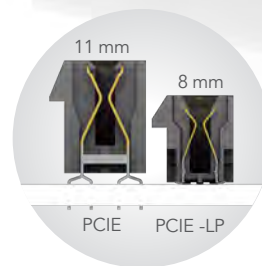

PCI-E® 3.0 & 4.0
Edge Card
connectors



PCI-E® 4.0 slim body
socket with Edge Rate®
contacts (PCI-E-G4)

KEY SPECIFICATIONS

SERIES	TOTAL PINS (LANES)	INSULATOR MATERIAL	CONTACT MATERIAL	OPERATING TEMP RANGE	CURRENT RATING	VOLTAGE RATING	PCI-E® COMPATIBILITY
PCI-E	36 (x1), 64 (x4), 98 (x8), 164 (x16)	-TH = Black Nylon -EMS2 & -TH = LCP	Phosphor Bronze	-55 °C to +125 °C	2.4 A (2 pins)	215 VAC/304 VDC	3.0
PCI-E-LP	36 (x1), 64 (x4), 98 (x8), 164 (x16)	LCP	Phosphor Bronze	-55 °C to +125 °C	2.1 A (2 pins)	215 VAC/304 VDC	4.0
PCI-E-G4	36 (x1), 64 (x4), 98 (x8), 164 (x16)	LCP	Copper Alloy	-55 °C to +125 °C	2.2 A (2 pins)	300 VAC/424 VDC	4.0
PCI-E-G5	36 (x1), 64 (x4), 98 (x8), 164 (x16)	LCP	Copper Alloy	-55 °C to +125 °C	3.2 A (2 pins)	220 VAC/311 VDC	5.0/6.0

PCI-SIG®, PCI Express® and the PCIe® design marks are registered trademarks and/or service marks of PCI-SIG.

(1.00 mm) .0394" PITCH • PCI EXPRESS® CARD SOCKETS

PCIE - **NUMBER OF POSITIONS** - **02** - **PLATING OPTION** - **D** - **TAIL OPTION**

-036, -064, -098, -164

-F
= Gold flash on contact,
Tin on tail

-EMS2
= Edge Mount

-TH
= Through-hole

-RA
= Right-angle

PCIE

Card Mates:
(1.60 mm)
.062" card
Cable Mates:
PCIEC

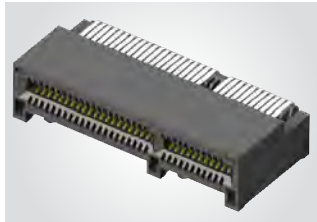

POSITIONS	A
-036 (x1)	(25.00) .984
-064 (x4)	(39.00) 1.535
-098 (x8)	(56.00) 2.205
-164 (x16)	(89.00) 3.504

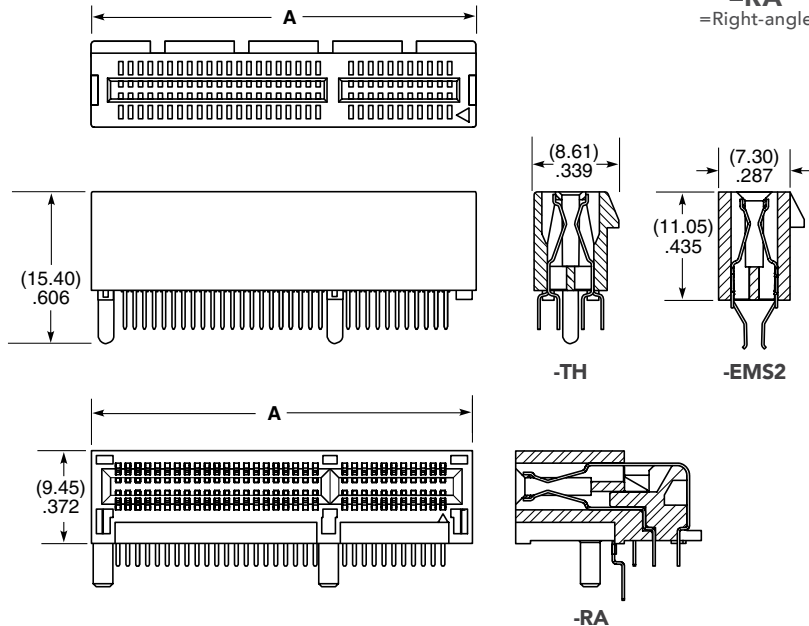

View complete specifications at: samtec.com?PCIE

PCIE - **LP** - **NUMBER OF LANES** - **01** - **PLATING OPTION** - **DV** - **A** - **OPTION** - **PACKAGING**

**-01, -04,
-08, -16**

-F
= Gold Flash on
contact, Matte
Tin on tail

-WT
= Weld Tab

(For -16 lanes
only leave blank for
Tray Packaging)

-K
= Polyimide film
Pick & Place Pad

-TR
= Tape & Reel
("X"R required with
-01, -04, -08 lanes)

PCIE-LP

Card Mates:
(1.60 mm)
.062" card
Cable Mates:
PCIEC

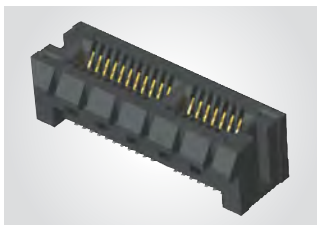

PCI-SIG®, PCI Express® and the PCIe® design marks are registered trademarks and/or service marks of PCI-SIG.

Note:
Some lengths, styles and options are non-standard, non-returnable.

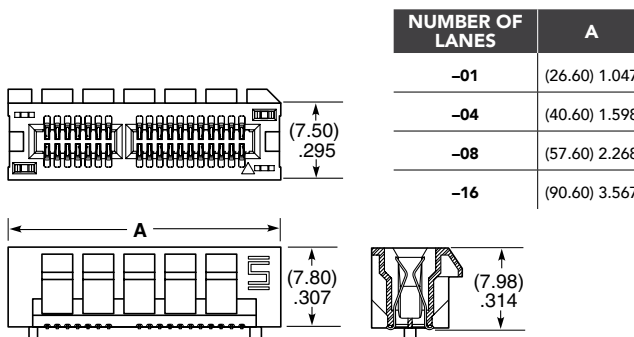

NUMBER OF LANES	A
-01	(26.60) 1.047
-04	(40.60) 1.598
-08	(57.60) 2.268
-16	(90.60) 3.567

-FR
= Full Reel
Tape & Reel
(must order max.
quantity per reel;
contact Samtec for
quantity breaks)
("X"R required with
-01, -04, -08 lanes)

View complete specifications at: samtec.com?PCIE-LP

(1.00 mm) .0394" PITCH • PCI EXPRESS® 4.0 SOCKET

PCIE	G4	NUMBER OF LANES	01	PLATING OPTION	DV	OPTION 1	OPTION 2	PACKAGING
------	----	-----------------	----	----------------	----	----------	----------	-----------

-01, -04,
-08, -16

-F
= Gold flash on contact, Matte Tin on tail

-A
= Alignment Pin (Not available with -WT)

-WT
= Weld Tab (Not available with -A)

-K
= (7.00 mm) .275" DIA Polyimide Pick & Place Pad

(For -16 lanes only leave blank for Tray Packaging)

-TR
= Tape & Reel ("X"R required with -01, -04, -08 lanes)

-FR
= Full Reel Tape & Reel (must order max. quantity per reel; contact Samtec for quantity breaks) ("X"R required with -01, -04, -08 lanes)

PCIE-G4
Card Mates:
(1.60 mm)
.062" card
Cable Mates:
PCIEC-G4

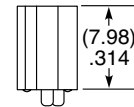
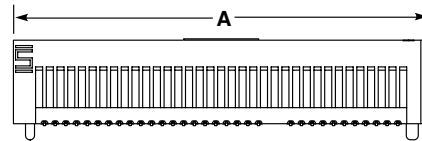
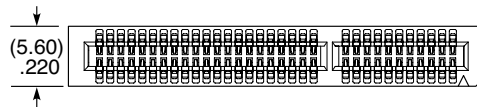
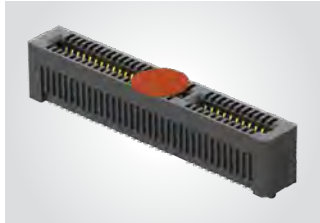

NUMBER OF LANES	A
-01	(24.80) .976
-04	(38.80) 1.528
-08	(55.80) 2.197
-16	(88.80) 3.496

View complete specifications at: samtec.com?PCIE-G4

(1.00 mm) .0394" PITCH • PCI EXPRESS® 5.0/6.0 SOCKET

PCIE	G5	NUMBER OF LANES	01	PLATING OPTION	TYPE	OPTION	PACKAGING
------	----	-----------------	----	----------------	------	--------	-----------

-01, -04,
-08, -16

-F
= Gold flash on contact, Matte Tin on tail

-DP-A
= Vertical

-WT
= Weld Tab

(For -16 lanes only leave blank for Tray Packaging)

-EM
= Edge Mount

-TR
= Tape & Reel ("X"R required with -01, -04, -08 lanes)

-FR
= Full Reel Tape & Reel (must order max. quantity per reel; contact Samtec for quantity breaks) ("X"R required with -01, -04, -08 lanes)

PCIE-G5
Card Mates:
(1.60 mm)
.062" card
Cable Mates:
PCIEC-G5

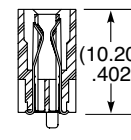
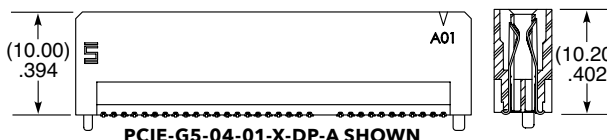
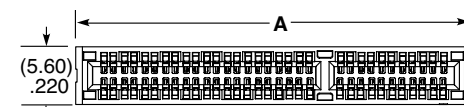
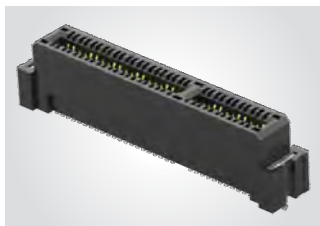

PCIE-G5-04-01-X-DP-A SHOWN

NUMBER OF LANES	A	B
-01	(24.40) .961	(27.40) 1.079
-04	(38.40) 1.512	(41.40) 1.630
-08	(55.40) 2.181	(58.40) 2.299
-16	(88.40) 3.480	(91.40) 3.598

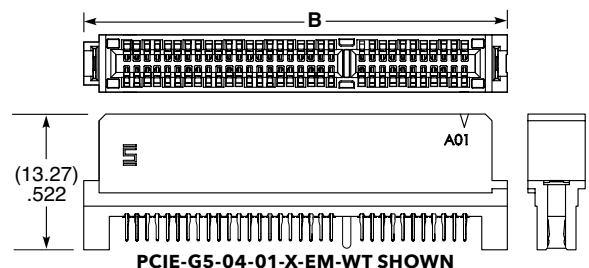

PCIE-G5-04-01-X-EM-WT SHOWN

PCI-SIG®, PCI Express® and the PCIe® design marks are registered trademarks and/or service marks of PCI-SIG.

Note:
Some lengths, styles and options are non-standard, non-returnable.

View complete specifications at: samtec.com?PCIE-G5

HIGH-SPEED BACKPLANE SYSTEMS

HIGH-DENSITY • DESIGN FLEXIBILITY • HIGH RELIABILITY

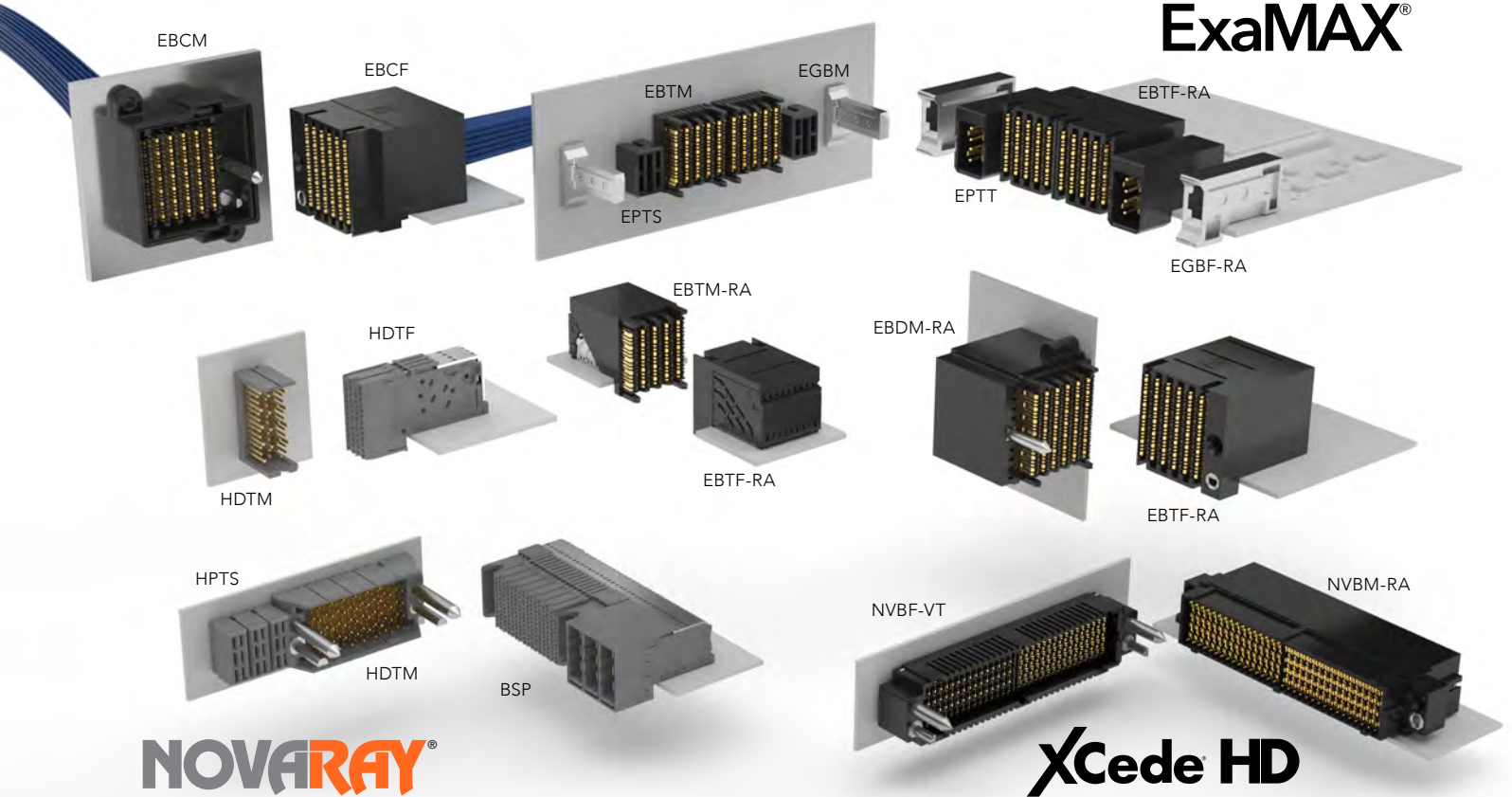

82-85

NovaRay®

Micro Rugged Backplane Header and Socket (NVBF, NVBM)	83
Micro Rugged Backplane Cable System (NVCF, NVCM)	84-85

86-91

ExaMAX®

ExaMAX® Vertical & Right-Angle Headers (EBTM)	87
ExaMAX® Right-Angle Receptacles (EBTF-RA)	88
ExaMAX® Direct-Mate Orthogonal Headers (EBDM-RA)	88
ExaMAX® Cables (EBCM, EBCF)	89-90
Power Modules for ExaMAX® (EPTT, EPTS)	91
Guidance Modules for ExaMAX® (EGBM, EGBF)	91
Panel Retention Brackets & Latching Shrouds for ExaMAX® Cables (EBCB, EBCL)	91

92-94

XCede® HD

XCede® HD Backplane Headers & Receptacles (HDTM, HDTF)	93-94
XCede® HD Power Modules (HPTS, HPTT)	94

MICRO RUGGED BACKPLANE SYSTEM

(0.90 mm) .0354" x (2.00 mm) .0787" PITCH

PAM4
128
Gbps

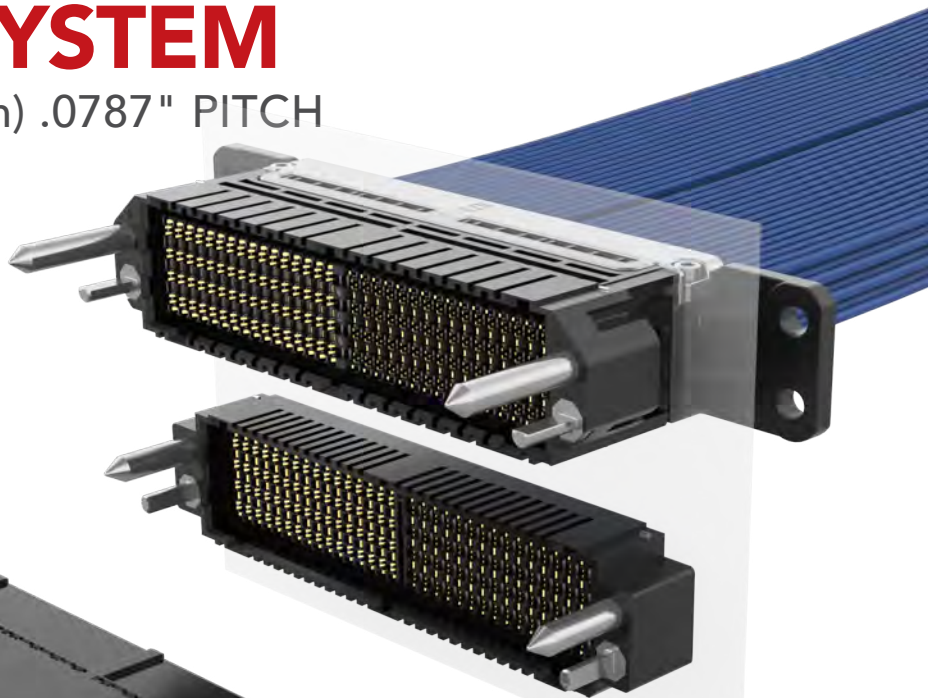

FEATURES & BENEFITS

- Ultra-high density with up to 128 DPs in a single connector
- PCIe® 7.0 capable
- Designed for blind mate applications
- Surface mount for better density and performance
- Innovative wafer design eliminates intra-pair skew
- Configurable signal banks for design flexibility
- Offset footprint for optimal signal integrity performance
- Large continuous ground blades between and surrounding the differential pairs eliminates resonances
- Optional guidance and keying
- Standard weld tabs for a secure connection to the board

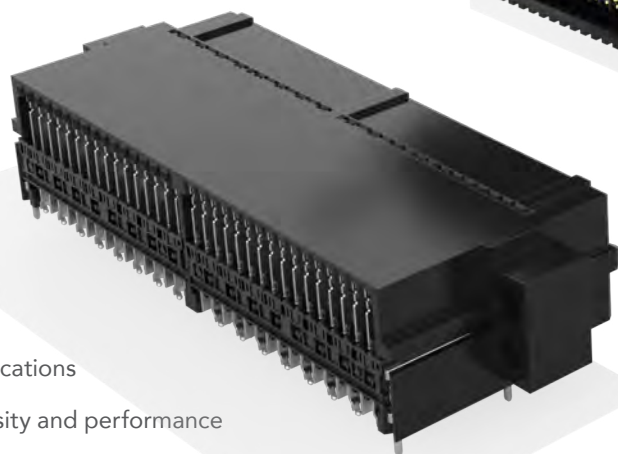

Ultra-high density; single-ended or differential pair wafers

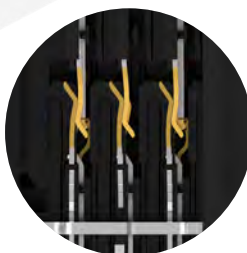

Precision insert molded contact system with 2.50 mm wiper



Flyover® cable assembly for extended signal reach

KEY SPECIFICATIONS

SERIES	INSULATOR MATERIAL	CONTACT MATERIAL	PLATING	OPERATING TEMP RANGE	CURRENT RATING	VOLTAGE RATING	LEAD-FREE SOLDERABLE
NVBM/NVBF	Black LCP	Copper Alloy	Au or Sn over 50 μ" (1.27 μm) Ni	Testing Now!	Testing Now!	Testing Now!	Yes
NVCF/NVCM	Black LCP	Copper Alloy	Au or Sn over 50 μ" (1.27 μm) Ni	Testing Now!	Testing Now!	Testing Now!	No

PCI-SIG®, PCI Express® and the PCIe® design marks are registered trademarks and/or service marks of PCI-SIG

0.90 mm x 2.00 mm PITCH • MICRO RUGGED BACKPLANE HEADER & SOCKET

SERIES	STYLE	NO. OF ROWS	ORIENTATION	PLATING OPTION	SOLDER TYPE	GUIDANCE	KEYING
--------	-------	-------------	-------------	----------------	-------------	----------	--------

NVBF
Socket

NVBM
Terminal

-DP
= 4 Pairs
per rows

-04, -16, -32

-VT
= Vertical
(NVBF)

-RA
= Right-Angle
(NVBM)

-S
= 30 μ" (0.76 μm)
Gold on contact
area, Matte Tin
on solder tail

-2
= Lead-Free
Solder Charge

(Leave Blank for
no Guidance)

-L
= Left
Guidance

-R
= Right Guidance

-B
= Both

(Only available
with Guidance)

-N
= No Key

-A thru -H
= Position of
flat on Key
(See Table)

PRELIMINARY

NVBF

Board Mates:
NVBM-RA



NO. OF ROWS	A	B
-04	(16.00) 0.630	(14.70) 0.579
-16	(40.00) 1.575	(38.70) 1.524
-32	(72.00) 2.835	(70.70) 2.783

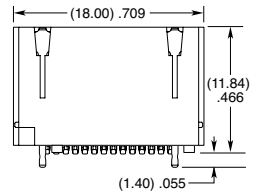
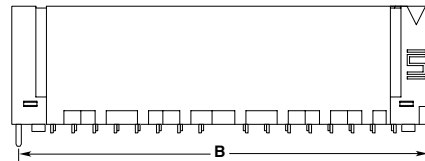
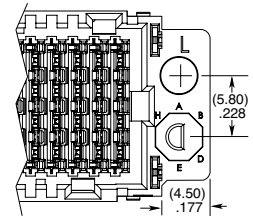
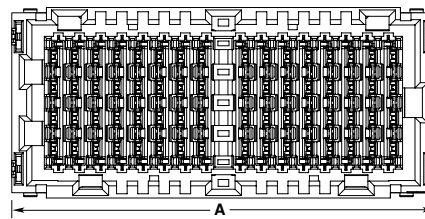

KEYING (-VT)								
-L / -R / -B	-A	-B	-C	-D	-E	-F	-G	-H

Notes:
Some sizes, styles and
options are non-standard,
non-returnable

View complete specifications at: samtec.com?NVBF

NVBM-RA

Board Mates:
NVBF-VT



PRELIMINARY

NO. OF ROWS	A	B	C
-04	(11.90) 0.469	(16.00) 0.630	(13.80) 0.543
-16	(35.90) 1.413	(40.00) 1.575	(37.80) 1.488
-32	(67.90) 2.673	(72.00) 2.835	(69.80) 2.748

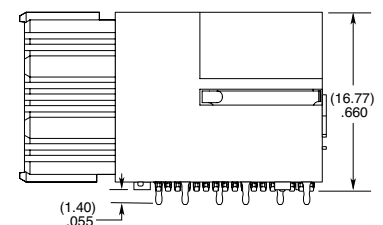
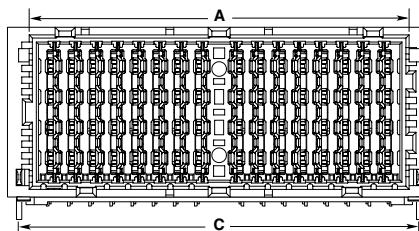
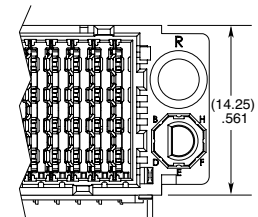
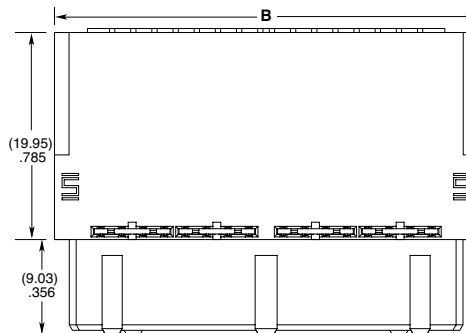

KEYING (-RA)								
-L / -R / -B	-A	-B	-C	-D	-E	-F	-G	-H

View complete specifications at: samtec.com?NVBM-RA

0.90 mm x 2.00 mm PITCH • MICRO RUGGED BACKPLANE CABLE

NVCF	SIGNAL TYPE	NO. OF ROWS	V	3	CABLE LENGTH	GUIDANCE MOUNTING	KEYING	GUIDANCE MOUNTING	KEYING	PIN OUT
	-DP = Differential Twinax pairs (4 pairs per row)	-04, -16, -32			-“XX” = Length in Inches 10” (152.4 mm) minimum	-0 = No Guidance -8 = Both Guidance, side mounting lugs	(Only available with Guidance) -N = No Key -A thru -H = Position of flat on Key (See Table)	-0 = No Guidance -8 = Both Guidance, side mounting lugs	(Only available with Guidance) -N = No Key -A thru -H = Position of flat on Key (See Table)	-1 = Pin A01 to Pin A01 -2 = Pin A01 to Pin R01 -3 = Pin A01 to Pin AN (N equals last row)

NVCF

Board Mates:
NVBM-RA

Cable Mates:
NVCM



KEYING (-VT)

	-A	-B	-C	-D	-E	-F	-G	-H
-L / -R / -B								

NO. OF ROWS	A	B	C
-04	(16.00) 0.630	(19.70) 0.776	(23.35) .919
-16	(40.00) 1.575	(31.70) 1.248	(35.35) 1.392
-32	(72.00) 2.835	(47.70) 1.878	(51.35) 2.022

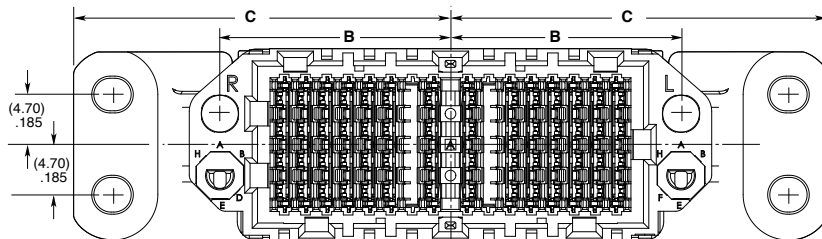

NVCF-DP-16-V-3-XX-8-A-8-A-X SHOWN

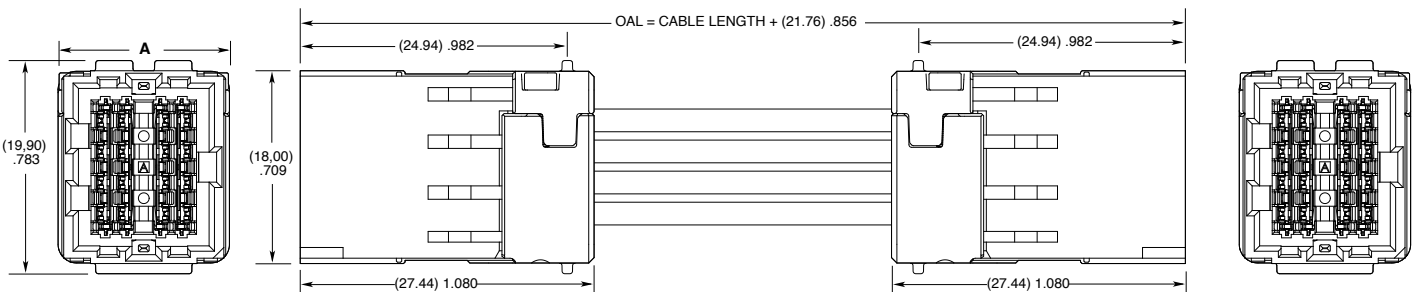
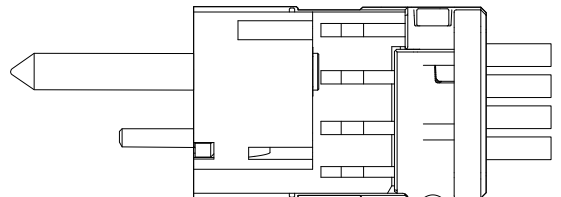

NVCF-DP-04-V-3-XX-0-N-0-N-X SHOWN

Notes:
Cable lengths longer than 1 meter (40.00") are not supported with S.I. test data.

Maximum standard cable length is 99 inches. For lengths greater than 99 inches contact HDR@samtec.com.

Some sizes, styles and options are non-standard, non-returnable.

View complete specifications at: samtec.com?NVCF

0.90 mm x 2.00 mm PITCH • MICRO RUGGED BACKPLANE CABLE

NVCM	SIGNAL TYPE	NO. OF ROWS	R	CABLE STYLE	CABLE LENGTH	END 1 GUIDANCE	END 1 KEYING	END 2 GUIDANCE	END 2 KEYING	PIN OUT
	-DP = Differential Twinax pairs (4 pairs per row)	-04, -16, -32		-3 = 34 AWG 92 Ω ultra low skew Thinax™	-XX = Length in inches 10" (254 mm) minimum	-0 = No Guidance -1 = Left Guidance -2 = Right Guidance -3 = Both	(Only available with Guidance) -N = No Key -A thru -H = Position of flat on Key	-0 = No Guidance -1 = Left Guidance -2 = Right Guidance -3 = Both	(Only available with Guidance) -N = No Key -A thru -H = Position of flat on Key (See Table)	-1 = Pin A01 to Pin A01 -2 = Pin A01 to Pin R01 -3 = Pin A01 to Pin AN (N equals last row)

PRELIMINARY

NVCM
Board Mates:
NVBF-VT
Cable Mates:
NVCF



KEYING								
-L / -R / -B	-A	-B	-C	-D	-E	-F	-G	-H

NO. OF ROWS	A	B	C
-04	(16.00) 0.630	(20.50) .807	(25.00) .984
-16	(40.00) 1.575	(44.50) 1.752	(49.00) 1.929
-32	(72.00) 2.835	(76.50) 3.012	(81.00) 3.189

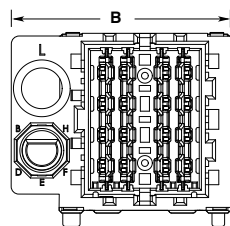

-1 GUIDANCE

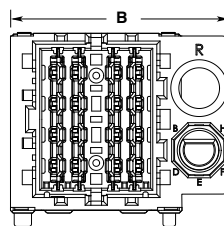

-2 GUIDANCE

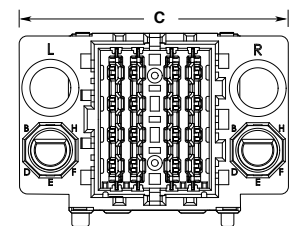

-3 GUIDANCE

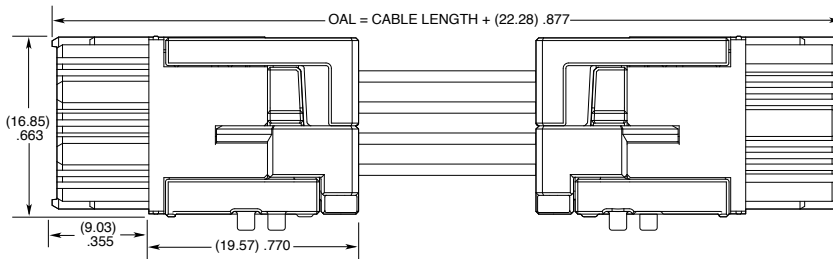
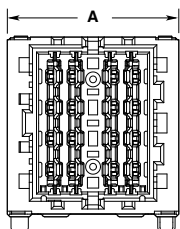

NVCM-DP-04-R-3-XX-0-N-0-N-X SHOWN

Notes:
Cable lengths longer than 1 meter (40.00") are not supported with S.I. test data.

Maximum standard cable length is 99 inches. For lengths greater than 99 inches contact HDR@samtec.com.

Some sizes, styles and options are non-standard, non-returnable.

View complete specifications at: samtec.com?NVCM

ExaMAX[®]

HIGH-SPEED BACKPLANE CONNECTOR & CABLE SYSTEMS

(2.00 mm) .0787" PITCH

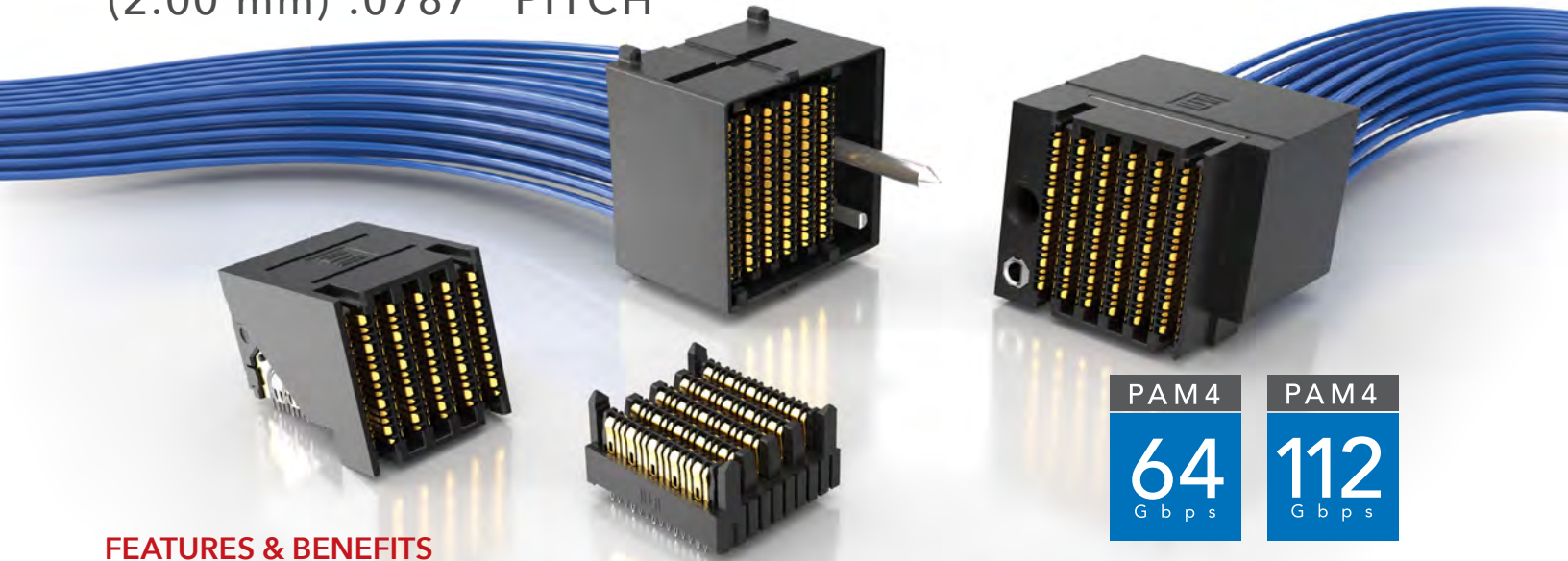

FEATURES & BENEFITS

ExaMAX[®] High-Speed Backplane System

- Meets a variety of industry specifications
- Traditional, coplanar and direct mate orthogonal
- 24 - 72 pair designs (4 and 6 pairs; 6, 8, 10 and 12 columns)
- Shielded wafer design reduces crosstalk and includes one sideband signal per column
- Press-fit tails provide a reliable electrical connection
- PCIe[®] 6.0/CXL[®] 3.2 capable

ExaMAX[®] High-Speed Backplane Cable Assemblies

- 30 & 34 AWG Eye Speed[®] ultra low skew twinax cable
- 34 AWG Eye Speed Thinax[™] ultra low skew twinax cable
- Offers improved signal integrity, increased flexibility and routability
- Highly customizable with modular flexibility
- Reduce costs due to lower layer counts
- PCIe[®] 6.0/CXL[®] 3.2 capable

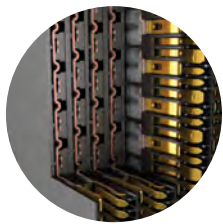

Staggered Differential Pair Design

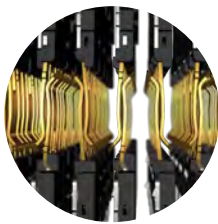

Two Reliable Points of Contact with a 2.4 mm Wipe



In Development: Open-Pin-Field, Coplanar Configuration



In Development: 2 Pair Design for a Lower Profile



In Development: ExaMAX2[®] 8 Pairs for 112 Gbps PAM4 Performance

KEY SPECIFICATIONS

SERIES	INSULATOR MATERIAL	CONTACT MATERIAL	PLATING	OPERATING TEMP RANGE	CURRENT RATING	VOLTAGE RATING	LEAD-FREE SOLDERABLE
EBTM/EBTF/EBDM	Liquid Crystal Polymer	Copper Alloy	Sn or Au over 50 μ" (1.27 μm) Ni	-55 °C to +105 °C	4 A per pin	150 VAC/212 VDC	Yes
EPTT/EPTS	High Temperature Thermoplastic	Copper Alloy	Sn or Au over 50 μ" (1.27 μm) Ni	-55 °C to +105 °C	14.1 A per pin	150 VAC/212 VDC	Yes
EBCM/EBCF	Liquid Crystal Polymer	Copper Alloy	Au over 50 μ" (1.27 μm) Ni	-40 °C to +105 °C	2.6 A per pin	125 VAC/177 VDC	N/A

PCI-SIG[®], PCI Express[®] and the PCIe[®] design marks are registered trademarks and/or service marks of PCI-SIG.

(2.00 mm) .0787" PITCH • VERTICAL & RIGHT-ANGLE HEADERS

EBTM	NO. OF PAIRS PER COLUMN	COLUMNS	COLUMN PITCH	PLATING	ORIENTATION	1	GUIDANCE	KEYING
	-4 = 4 Pairs	-06, -08, -10, -12 (-12 column only available in -6 pairs)	-2.0 = (2.0 mm) .0787"	-S = 30 μ" (0.76 μm) Gold on contact area, Matte Tin on tail	-VT = Vertical		(Leave Blank for no Guidance) -L = Left Guidance -R = Right Guidance	(Only available with -L or -R Guidance) (Leave Blank for no Keying) -A thru -H = Position of flat on Key (See Table)

EBTM-VT
Board Mates:
EBTF-RA

Cable Mates:
EBCF

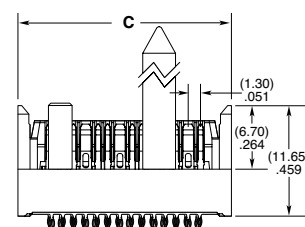
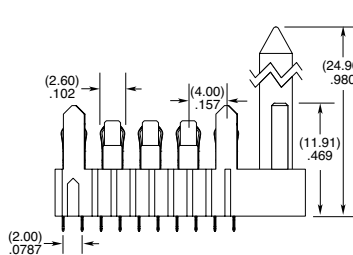
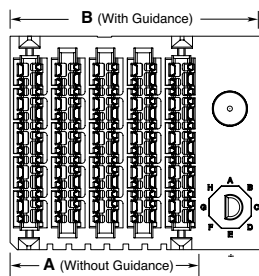
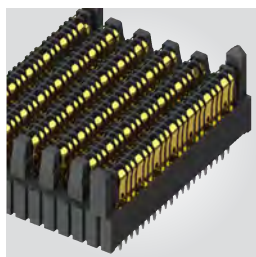

KEYING (-VT)								
-L / -R	-A	-B	-C	-D	-E	-F	-G	-H

COLUMNS	A	B
-06	(11.90) .469	(18.35) .722
-08	(15.90) .626	(22.35) .880
-10	(19.90) .783	(26.35) 1.037
-12	(23.90) .941	(30.35) 1.195

NO. OF PAIRS PER COLUMN	C
-4	(22.50) .886
-6	(29.70) 1.169

View complete specifications at: samtec.com?EBTM

EBTM-RA
Board Mates:
EBTF-RA

Cable Mates:
EBCF

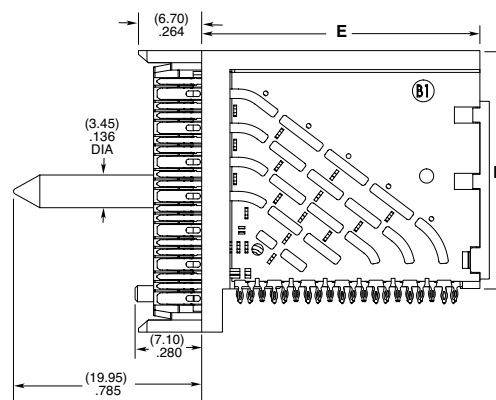
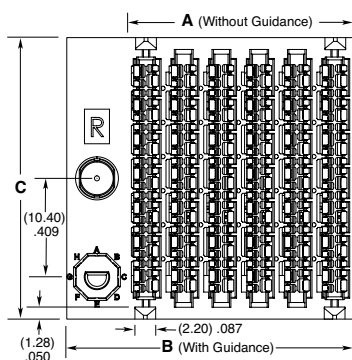
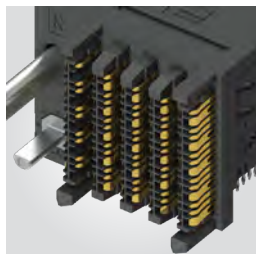

KEYING (-RA)								
-L / -R	-A	-B	-C	-D	-E	-F	-G	-H

COLUMNS	A	B
-06	(11.90) .469	(18.35) .722
-08	(15.90) .626	(22.35) .880
-10	(19.90) .783	(26.35) 1.037
-12	(23.90) .941	(30.35) 1.195

NO. OF PAIRS PER COLUMN	C	D	E
-4	(22.50) .886	(17.90) .705	(23.30) .917
-6	(29.70) 1.169	(25.10) .988	(30.50) 1.201

Notes:
Some lengths, styles and options are non-standard, non-returnable.

ExaMAX[®] is a registered trademark of Amphenol FCI Asia Pte. Ltd. Used with permission.

View complete specifications at: samtec.com?EBTM-RA

(2.00 mm) .0787" PITCH • RIGHT-ANGLE SOCKET & DIRECT-MATE ORTHOGONAL

EBTF	NO. OF PAIRS PER COLUMN	COLUMNS	COLUMN PITCH	PLATING	RA	1	GUIDANCE	KEYING
	-4 = 4 Pairs -6 = 6 Pairs	-06, -08, -10, -12 (-12 column only available in -6 pairs)	-2.0 = (2.0 mm) .0787"	-S = 30 μ" (0.76 μm) Gold on contact area, Matte Tin on tails			(Leave Blank for no Guidance) -L = Left Guidance -R = Right Guidance	(Only with -L or -R Guidance; Leave Blank for no Keying) -A thru -H = Position of Flat on Key (See Table)

EBTF-RA
Board Mates:
EBTM,
EBDM-RA

Cable Mates:
EBCM

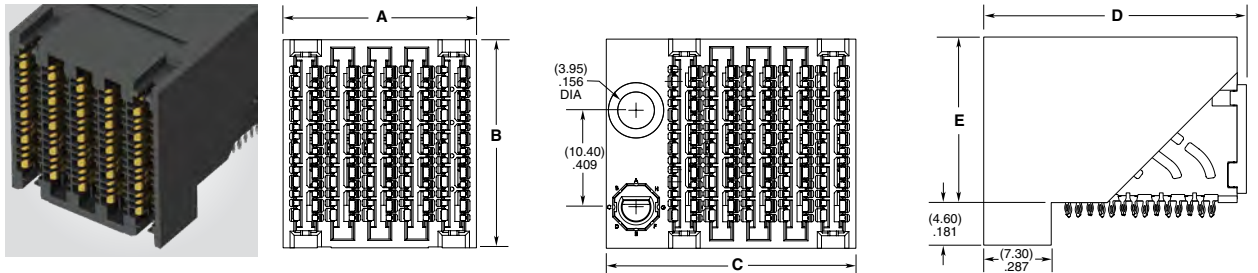

KEYING (-RA)								
-L / -R	-A	-B	-C	-D	-E	-F	-G	-H

NO. OF COLUMNS	A	C
-06	(12.90) .508	(18.85) .742
-08	(16.90) .665	(22.85) .900
-10	(20.90) .823	(26.85) 1.057
-12	(24.90) .980	(30.85) 1.215

NO. OF PAIRS PER COLUMN	B	D	E
-4	(22.50) .886	(28.40) 1.118	(17.90) .705
-6	(29.70) 1.169	(35.60) 1.402	(25.10) .988

View complete specifications at: samtec.com?EBTF-RA

EBDM	PAIRS	COLUMNS	2.0	PLATING	RA	1	GUIDANCE	SCREW MOUNT
	-6 = 6 Pairs	-06, -08, -10, -12		-S = 30 μ" (0.76 μm) Gold on contact area, Matte Tin on tails			(Leave Blank for no Pin) -G = Guide Pin	(Leave Blank for no Screw Mount) -S = Screw Mount

EBDM-RA
Board Mates:
EBTF-RA

Cable Mates:
EBCF

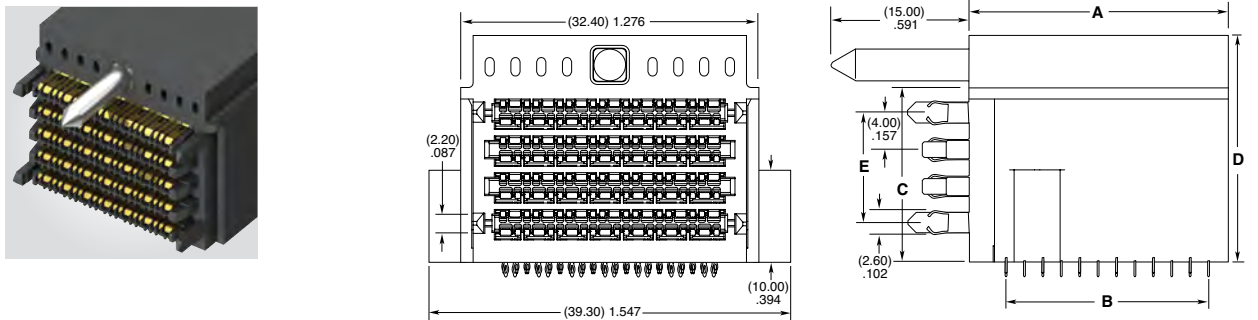

COLUMNS	A	B	C (without -G)	D (with -G)	E
-06	(16.15) .636	(10.00) .394	(15.00) .591	(20.65) .813	(8.00) .315
-08	(20.15) .793	(14.00) .551	(19.00) .748	(24.65) .970	(12.00) .472
-10	(24.15) .951	(18.00) .709	(23.00) .906	(28.65) 1.128	(16.00) .630
-12	(28.15) 1.108	(22.00) .866	(27.00) 1.063	(32.65) 1.285	(20.00) .787

Notes:
Some lengths, styles and options are non-standard, non-returnable.

ExaMAX[®] is a registered trademark of Amphenol FCI Asia Pte. Ltd. Used with permission.

View complete specifications at: samtec.com?EBDM-RA

(2.00 mm) .0787" PITCH • BACKPLANE CABLES

EBCM	CABLE/SIG. MAP	PAIRS PER COLUMN	COLUMNS	END 1 PIN	END 1 GUIDE	END 1 KEY	CABLE LENGTH	END 2 PIN	END 2	END 2 KEY
Cable Header	<p>-1 = 34 AWG ultra low skew twinax cable/ Tx to Rx Sig. Map</p> <p>-2 = 30 AWG ultra low skew twinax cable/ Tx to Rx Sig. Map</p> <p>-3 = 34 AWG ultra low skew twinax cable/ 1:1 Sig. Map</p> <p>-4 = 30 AWG ultra low skew twinax cable/ 1:1 Sig. Map</p> <p>-6 = 34 AWG Thinax™ ultra low skew twinax cable/ Tx to Rx Sig. Map</p> <p>-8 = 34 AWG Thinax™ ultra low skew twinax cable/ 1:1 Sig. Map</p>	<p>-4 = 4 Pairs</p> <p>-6 = 6 Pairs</p>	<p>-04, -08, -10, -12, -14, -16</p>	<p>-1 = Standard</p>	<p>-L = Left Guidance</p> <p>-R = Right Guidance</p>	<p>-A thru -H = Position of Flat on Key (See Table)</p> <p>-N = No Key</p>	<p>"XX" = Length in Inches</p> <p>4 Pairs: 06" (152.4 mm) minimum</p> <p>6 Pairs: 08" (203.2 mm) minimum</p>	<p>-1 = Standard</p>	<p>-L = Male, Left Guidance</p> <p>-R = Male, Right Guidance</p> <p>-FL = Female, Right-angle Left Guidance (-3, -4 & -8 Signal Map only)</p> <p>-FR = Female, Right-angle Right Guidance (-3, -4 & -8 Signal Map only)</p> <p>-FV = Female, Vertical (-3, -4 & -8 Signal Map only)</p>	<p>(Leave Blank for -FV End 2)</p> <p>-A thru -H = Position of Flat on Key (See Table)</p> <p>-N = No Key</p>

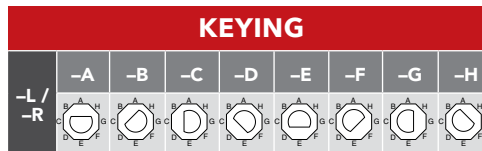

EBCM
Mates with:
EBCF, EBTF
Retention
Bracket:
EBCB



NO. OF COLUMNS	A	PAIRS PER COLUMN	B
-04	(17.45) .687		
-06	(21.45) .845	-4	(24.80) .976
-08	(25.45) 1.002	-6	(32.00) 1.260
-10	(29.45) 1.159		
-12	(33.45) 1.317		
-14	(37.45) 1.474		
-16	(41.45) 1.632		

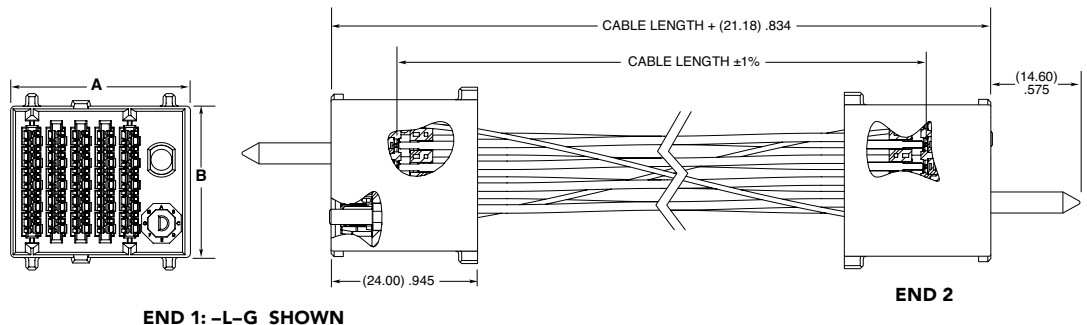

Notes:
Some lengths, styles and options are non-standard, non-returnable.

ExaMAX[®] is a registered trademark of Amphenol FCI Asia Pte. Ltd. Used with permission.

View complete specifications at: samtec.com?EBCM

EBCF	CABLE/ SIG. MAP	PAIRS / COLUMN	COLUMNS	END 1	END 1 PIN	CABLE LENGTH	END 2 OPTION	END 2 PIN	END 2 GUIDE	END 2 KEY
Cable Socket	<p>-1 = 34 AWG ultra low skew twinax cable/Tx to Rx Sig. Map</p> <p>-2 = 30 AWG ultra low skew twinax cable/Tx to Rx Sig. Map</p> <p>-3 = 34 AWG ultra low skew twinax cable/1:1 Sig. Map</p> <p>-4 = 30 AWG ultra low skew twinax cable/1:1 Sig. Map</p> <p>-6 = 34 AWG Thinax™ ultra low skew twinax cable/Tx to Rx Sig. Map</p> <p>-8 = 34 AWG Thinax™ ultra low skew twinax cable/1:1 Sig. Map</p>	<p>-4 = 4 Pairs</p> <p>-6 = 6 Pairs</p>	<p>-04, -08, -10, -12, -14, -16</p>	<p>-V = Vertical Latch</p>	<p>-1 = Standard</p>	<p>"-XX" = Length in Inches 4 Pairs: 06" (152.4 mm) minimum 6 Pairs: 08" (203.2 mm) minimum</p>	<p>-V = Vertical Latch</p> <p>-R = Right-Angle</p>	<p>-1 = Standard</p>	<p>(-R End Only)</p> <p>-L = Left Guidance</p> <p>-R = Right Guidance</p>	<p>(Leave Blank for no Key; -R End Only)</p> <p>-A thru -H = Position of Flat on Key (See Table)</p>

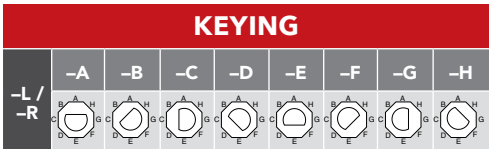

EBCF
Mates with:
EBCM, EBTM
Latching
Shroud:
EBCL



NO. OF COLUMNS	PAIRS PER COLUMN		
	A	C	E
-04	(10.60) .417	(14.85) .585	(19.15) .754
-06	(14.60) .575	(18.85) .742	(23.15) .911
-08	(18.60) .732	(22.85) .900	(27.15) 1.069
-10	(22.60) .890	(26.85) 1.057	(31.15) 1.226
-12	(26.60) 1.047	(30.85) 1.215	(35.15) 1.384
-14	(30.60) 1.205	(34.85) 1.372	(39.15) 1.541
-16	(34.60) 1.362	(38.85) 1.530	(43.15) 1.699

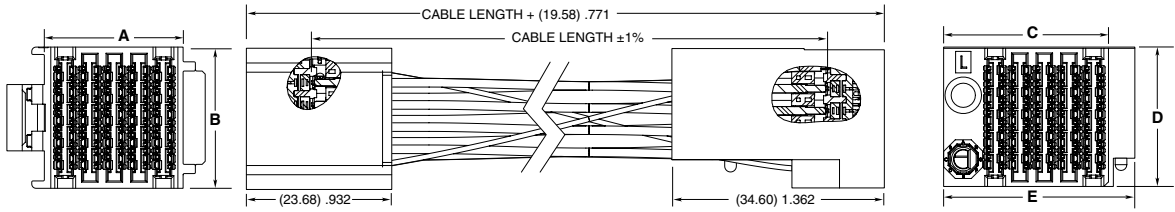

Notes:
Some lengths, styles and options are non-standard, non-returnable.

ExaMAX[®] is a registered trademark of Amphenol FCI Asia Pte. Ltd. Used with permission.

View complete specifications at: samtec.com?EBCF

POWER MODULES



EPTT
Terminal



EPTS
Socket

- 2.00 mm (.0787") pitch
- 4 total positions (2 positions per row)
- Vertical and right-angle for coplanar and perpendicular applications
- Pin staging options (EPTS)
- Plating: Palladium with flash gold on contacts, matte tin on tails
- Part numbers and specifications available at samtec.com?eptt or samtec.com?epts

GUIDE MODULES



EGBM
Terminal



EGBF
Socket

- Vertical and right-angle for coplanar and perpendicular applications
- External or internal threading (EGBM)
- 20 mm (.787") card spacing (EGBF)
- Insulator material: Zinc Alloy
- Part numbers and specifications available at samtec.com?egbm or samtec.com?egbf

PANEL RETENTION BRACKETS & LATCHING SHROUDS

EBCB
Panel Retention
Bracket

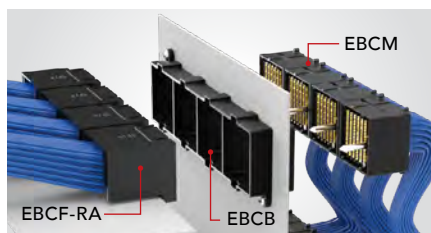

- ExaMAX[®] cable assemblies lock into the retention bracket for a secure connection on the panel
- Variety of sizes to accommodate ExaMAX[®] interconnects with 4 or 6 differential pairs in 4 to 16 column widths
- 1, 2 or 4 banks; side lugs available for mounting
- Part numbers and specifications available at samtec.com?ebcb

EBCL
Vertical Latching
Shroud

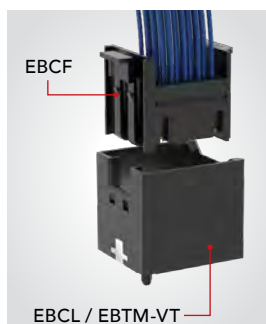

- Vertical latching shroud provides a secure cable-to-board connection
- Single bank only
- Accommodates ExaMAX[®] interconnects with 4 or 6 differential pairs in 6 to 12 column widths
- Part numbers and specifications available at samtec.com?ebcl

Note: ExaMAX[®] is a registered trademark of Amphenol FCI Asia Pte. Ltd. Used with permission.

HIGH-DENSITY BACKPLANE HEADERS & SOCKETS

(1.80 mm) .071" PITCH

16
Gbps

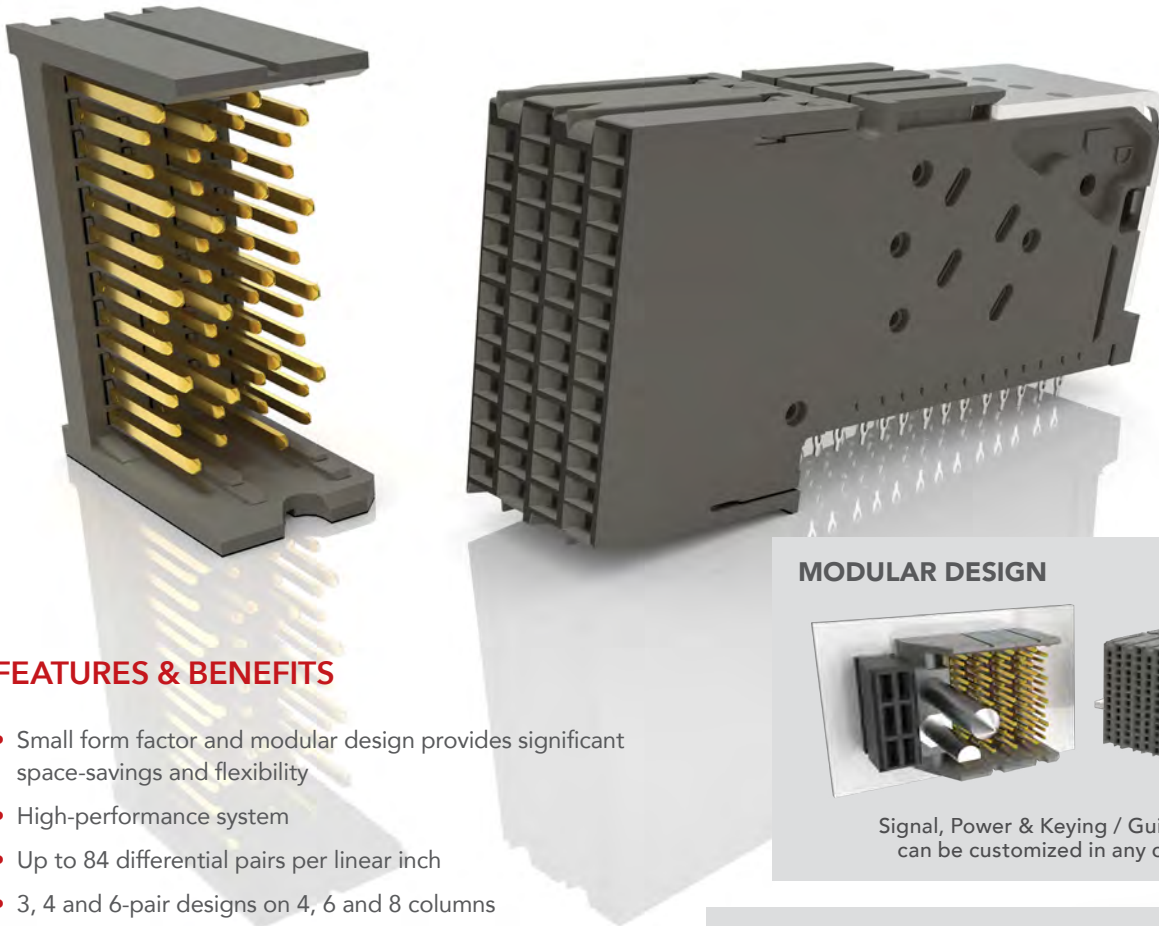

FEATURES & BENEFITS

- Small form factor and modular design provides significant space-savings and flexibility
- High-performance system
- Up to 84 differential pairs per linear inch
- 3, 4 and 6-pair designs on 4, 6 and 8 columns
- Integrated power, guidance, keying and side walls available
- 85 Ω and 100 Ω options
- Combine any configuration of modules to create one integrated receptacle (BSP Series); corresponding terminal modules are individually mounted to the backplane. Visit samtec.com?BSP or contact HSBP@samtec.com
- Press-fit extraction and insertion tool options; please visit samtec.com/tooling for details

MODULAR DESIGN

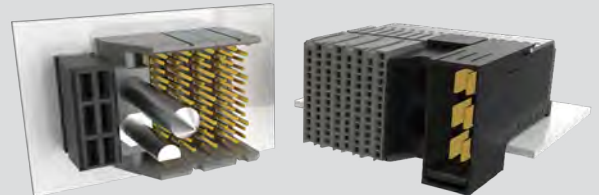

Signal, Power & Keying / Guidance options can be customized in any configuration

HIGH-DENSITY, SMALL FORM FACTOR



XCede[®] HD
Up to 84 pairs per linear inch



Traditional Backplane
Up to 76 pairs per linear inch

(Both shown with six 4-pair, 8 column receptacles)

KEY SPECIFICATIONS

SERIES	INSULATOR MATERIAL	CONTACT MATERIAL	PLATING	OPERATING TEMP RANGE	CURRENT RATING	VOLTAGE RATING
HDTM/HDTF	LCP	Phosphor Bronze (HDTM) Copper Alloy (HDTF)	Au or Sn over 50 μ" (1.27 μm) Ni	-40 °C to + 105 °C	1.5 A per contact	48 VAC/ /68 VDC
HPTS/HPTT	LCP	Copper Alloy	Au or Sn over 50 μ" (1.27 μm) Ni	-40 °C to + 105 °C	10 A per blade	48 VAC/ /68 VDC

(1.80 mm) .071" PITCH • HIGH-DENSITY BACKPLANE HEADER

HDTM	PAIRS	NO. OF COLUMNS	TAIL SIZE	S	VT	SIDE WALLS	GUIDANCE	STAGE COMBO	KEYING
	-3, -4, -6 =Pairs Per Column	-04, -06, -08	-1 =(.4495 mm) .0177" Drill -2 =(.5511 mm) .0217" Drill			-0 = Open (No Walls) -1 = Left -2 = Right -4 = Left Polarizing with left guidance (-4 Pairs N/A) -5 = Right Polarizing with right guidance (-4 Pairs N/A)	-4 or -5 Polarizing Only; Leave Blank for No Guidance -L = Left Side Guide Pin (-4 Pairs N/A) -R = Right Side Guide Pin (-4 Pairs N/A)	-1 = 3 mm Wipe Signal / 4 mm Wipe Ground -2 = 2 mm Wipe Signal / 4 mm Wipe Ground -3 = 3 mm Wipe Signal / 3 mm Wipe Ground -4 = 2 mm Wipe Signal / 3 mm Wipe Ground -5 = 2 mm Wipe Signal / 2 mm Wipe Ground	-4 or -5 Polarizing Only; Leave Blank for No Keying -A thru -H = Position of Flat on Key (See Table)

HDTM Board Mates:
HDTF, BSP

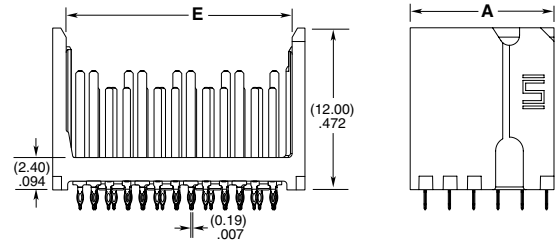
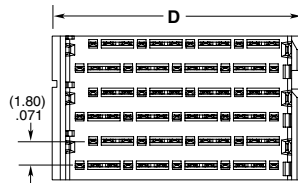
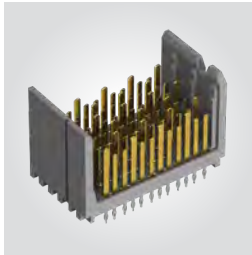

HDTM-4-06-1-S-VT-0-1 SHOWN

NO. OF COLUMNS	A			C	
	No Walls	Left Wall	Right Wall	Left Polarize	Right Polarize
-04	(7.06) .278	(8.20) .323	(8.06) .317	N/A	N/A
-06	(10.66) .420	(11.80) .465	(11.66) .459	(17.14) .675	(16.65) .656
-08	(14.26) .561	(15.40) .606	(15.26) .600	(20.74) .817	(20.25) .797

PAIRS PER COLUMN	D	E
	Standard Wall	
-03	(15.10) .594	(13.15) .518
-04	(18.70) .736	(16.75) .659
-06	(25.90) 1.020	(23.95) .943

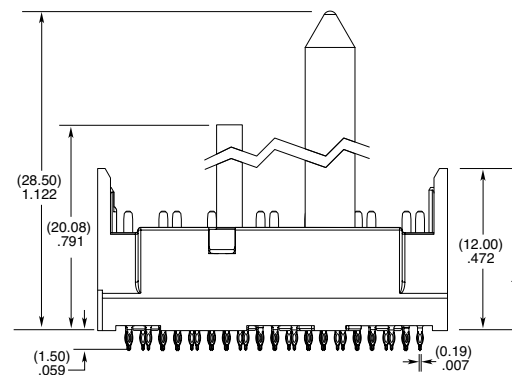
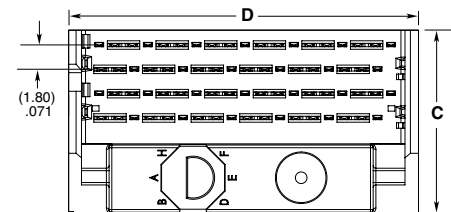

HDTM-6-04-X-X-VT-4-L-X-A SHOWN

KEYING								
-L / -R	-A	-B	-C	-D	-E	-F	-G	-H

Notes:
Some lengths, styles and options are non-standard, non-returnable.
XCede® is a registered trademark of Amphenol.

View complete specifications at: samtec.com?HDTM

(1.80 mm) .071" PITCH • HIGH-DENSITY BACKPLANE RECEPTACLE

HDTF	PAIRS PER COLUMN	NO. OF COLUMNS	PLATING	RA	WAFERS	IMPEDANCE
	-3, -4, -6	-04, -06, -08	-S = 30 μ" (0.76 μm) Gold on Contact Area, Matte Tin on Tail		-LC = Standard -HS = High-Speed	-100 = 100 Ω -085 = 85 Ω

HDTF Board Mates:
HDTM

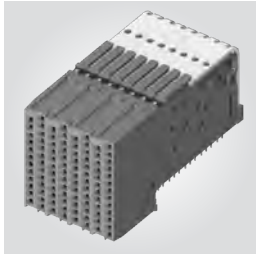
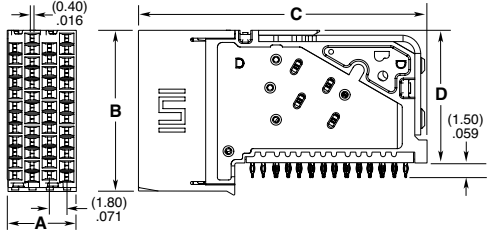
NO. OF COLUMNS	A	PAIRS PER COLUMN	B	C	D
-04	(7.2) .283	-3	(12.8) .504	(26.0) 1.02	(9.9) .390
-06	(10.8) .425	-4	(16.4) .646	(29.4) 1.16	(13.5) .531
-08	(14.4) .567	-6	(23.6) .929	(36.6) 1.44	(20.7) .815

View complete specifications at: samtec.com?HDTF

(3.20 mm) .126" PITCH • POWER MODULES

HPTS	BODY HEIGHT	PLATING	D	ORIENTATION
= Socket	Based on Pair Count of Signal Modules (HDTM)	-S = Standard Gold on Contact Area, Matte Tin on Tail		-VT = Vertical

HPTS Mates with:
HPTT, BSP

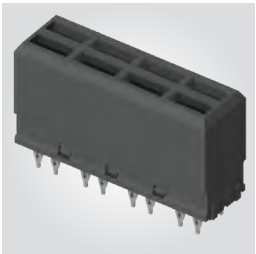
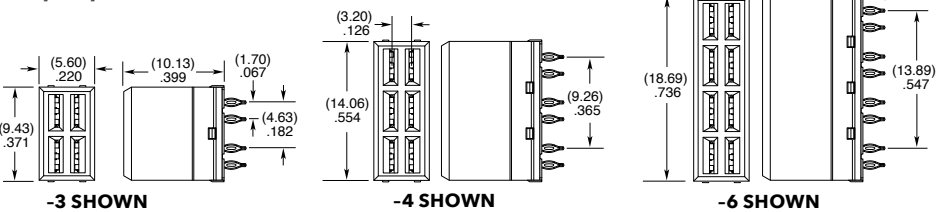
View complete specifications at: samtec.com?HPTS

HPTT	BODY HEIGHT	PLATING	POSITION NO. 1	POSITION NO. 2	POSITION NO. 3	POSITION NO. 4	D	ORIENTATION
= Terminal	Based on Pair Count of Signal Modules (HDTF, BSP)	-S = Standard Gold on Contact Area, Matte Tin on Tail	Contact Wipe Column A & B	Contact Wipe Column A & B	Contact Wipe Column A & B (-4 & -6 Height Only)	Contact Wipe Column A & B (-6 Height Only)		-RA = Right-angle
	-3, -4, -6		-3 = (4.5 mm) 0.18" -6 = (5.5 mm) 0.22"	-3 = (4.5 mm) 0.18" -6 = (5.5 mm) 0.22"	-3 = (4.5 mm) 0.18" -6 = (5.5 mm) 0.22"	-3 = (4.5 mm) 0.18" -6 = (5.5 mm) 0.22"		

HPTT Mates With:
HPTS

BODY HEIGHT	A	B	C
-3	(13.8) .543	(28.1) 1.11	(9.80) .386
-4	(17.4) .685	(31.2) 1.23	(13.50) .531
-6	(24.6) .969	(38.7) 1.52	(20.70) .815

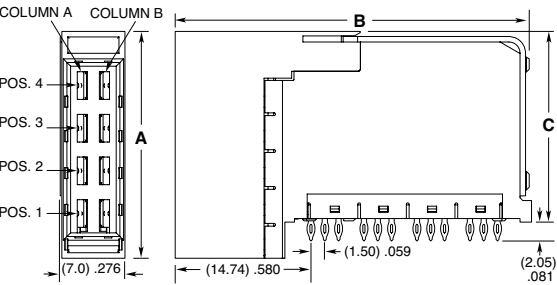
View complete specifications at: samtec.com?HPTT

Notes:
Some lengths, styles and options are non-standard, non-returnable. XCede® is a registered trademark of Amphenol.

HIGH-SPEED CABLE PANEL ASSEMBLIES

FLYOVER® TECHNOLOGY • UP TO 128 Gbps PAM4 PER CHANNEL • VARIETY OF END OPTIONS

98-103

FLYOVER® SFP, OSFP, QSFP
CABLE SYSTEMS
(FSFP, FOSFP-1, FOSFP-2,
FQSFP-D8, FQSFP)

 FLYOVER®



104-107

NOVARAY® I/O EXTREME
PERFORMANCE SYSTEMS
(NVACP, NVC, NVACE, NVA3E, NVA3P)

 NOVARAY® I/O



108-109

EXAMAX® I/O SHIELDED CABLE SYSTEM (EBTC, EBCE)

 ExaMAX®





FLYOVER® TECHNOLOGY

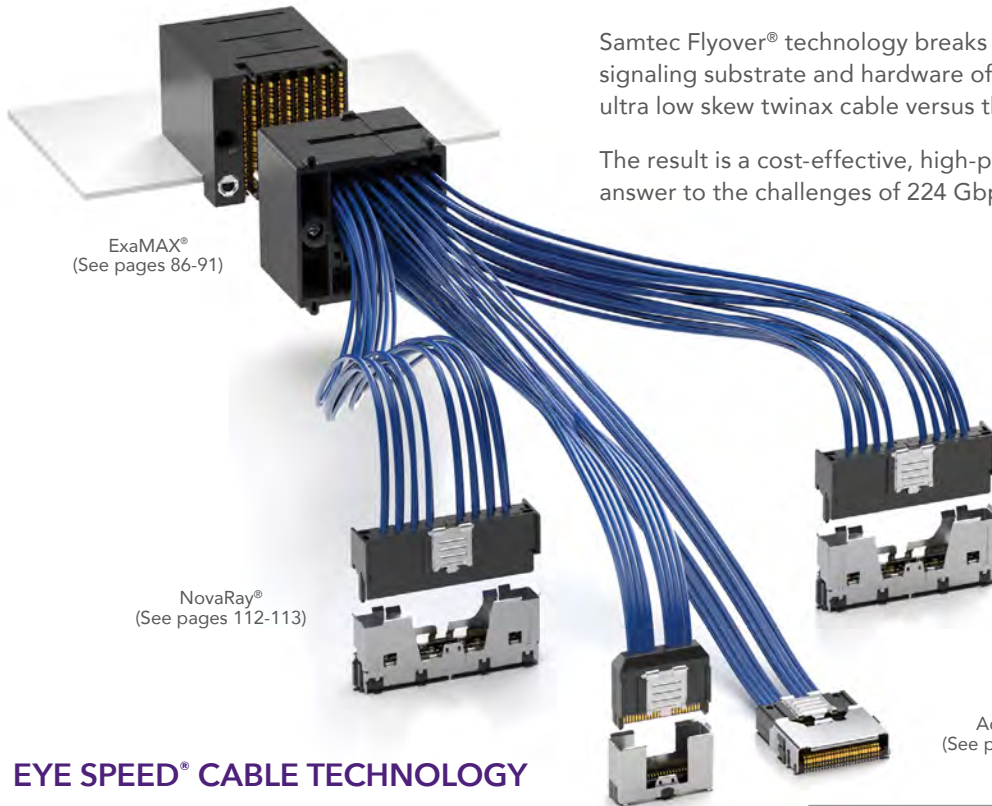

ExaMAX®
(See pages 86-91)

NovaRay®
(See pages 112-113)

AcceleRate®
(See pages 116-117)

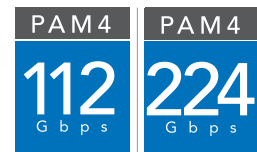

EYE SPEED® CABLE TECHNOLOGY

- Ideal for all high-performance applications up to 224+ Gbps PAM4 data rates
- Tight coupling between signal conductors
- Ultra low skew twinax 3.5 ps/meter max. (intrapair)
- Hyper low skew twinax 1.75 ps/meter max. (intrapair)
- Improved signal integrity and eye pattern opening
- Increased bandwidth and reach
- Differential pair, single-ended (Eye Speed ThinSE™) and mixed signaling available
- Taped jacket miniaturizes the cable for easier routing, overall weight reduction and increased air flow (Eye Speed Thinax™ and hyper low skew twinax)

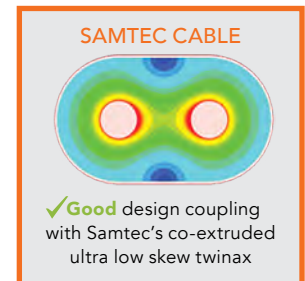
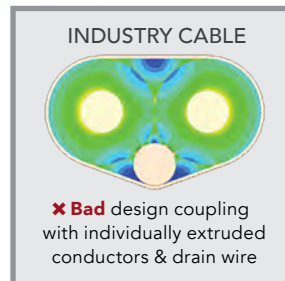

THERMAL IMPROVEMENT

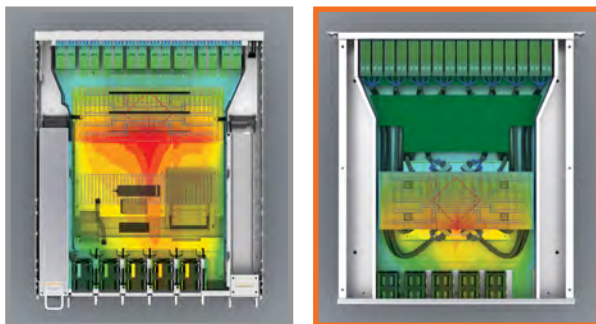

Standard Network Switch vs. Samtec Flyover® Technology

PERFORMANCE & COST ADVANTAGES

- Up to 224 Gbps PAM4 and beyond
- Simplified board layout
- Less expensive PCB materials, fewer PCB layers
- Eliminates expensive re-timers

SUPPORT

Fully integrated technology teams for full system optimization from Silicon-to-Silicon™, including Samtec's High-Speed Cable Plants.

CABLE SPECIFICATIONS



EYE SPEED® CABLE TECHNOLOGY INCLUDES 4 VARIETIES:

EYE SPEED® TWINAX

- Ultra low skew: 3.5 ps/meter max
- Co-extruded: tight coupling between signal conductors
- Impedance control and perfect intra-pair sequencing
- Impedance (Ω): 92, 85 or 100

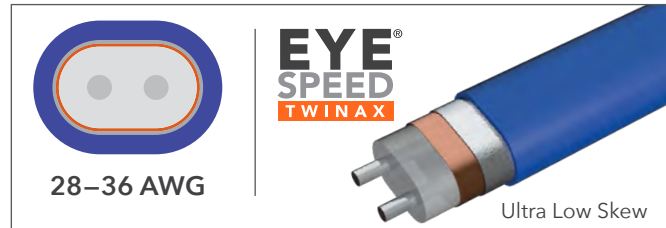

Series: ARC6, ARM6, CPC, EBCF, EBCM, EBCE, FQSFP, FQSFP-DD, FQSFP-D8, NVA3E, NVA3P, NVAC, NVACE, NVACP

EYE SPEED THINAX™

- 40% smaller cross-sectional area versus Eye Speed® Twinax
- Reduction in overall weight and maximizes air flow
- Easy to route through systems
- Ultra low skew: 3.5 ps/meter max
- Impedance (Ω): 92



Series: ARC6, ARM6, ARP6, EBCF, EBCM, FOSFP, FQSFP, FQSFP-D8, FSFP, NVAC, NVACE, NVACP

EYE SPEED® HYPER LOW SKEW TWINAX

- Hyper low skew: 1.75 ps/meter max
- Insertion Loss: 14.3 dB (1 m length at 56 GHz)
- Easy to route through systems
- Impedance (Ω): 92
- 28 AWG in development

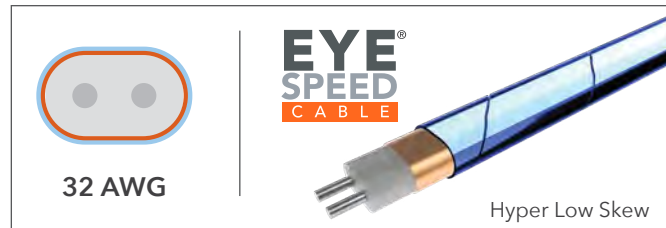

Series: SFCC, SFNC

EYE SPEED THINSE™

- Small .024" outer diameter cable for 34 AWG variant
- Min. bend radius: 0.125-inch (one-time bend)
- Supports single-ended and mixed signaling (-DP & -SE) of Samtec high-performance cable assemblies
- Impedance (Ω): 50



Series: ARP6, EBCF, EBCM



FLYOVER[®] SFP, QSFP & OSFP PANEL ASSEMBLIES



PAM4	PAM4	PAM4
56	112	224
Gbps	Gbps	Gbps

FEATURES & BENEFITS

Flyover[®] panel cable systems utilize Samtec Flyover[®] cable technology to route data above lossy PCB through Eye Speed[®] ultra low skew twinax cable, simplifying board layout and extending signal reach. The modular design enables optimized systems that improve heat management, increase signal integrity performance, build in scalability for future upgrades and reduce costs by creating a multifunction board.

- High-speed contacts directly terminated to Eye Speed[®] ultra low skew twinax
- Low-speed and power positions transmitted through press-fit contact tails
- Multiple end 2 (co-packaged and near-chip) options for design flexibility
- Cages and heat sinks available for optimized thermal performance
- SI Evaluation Kits available, visit samtec.com/kits

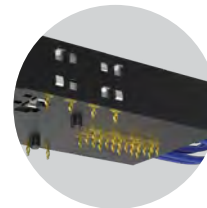

FLYOVER[®] SFP SYSTEM

- 112 Gbps PAM4 performance
- Belly-to-belly capable for maximum density
- Accepts all MSA compliant SFP pluggable modules
- Eye Speed Thinax[™] ultra low skew twinax cable (3.5 ps/m max)

FLYOVER[®] QSFP SYSTEM

- 4 Channels (x4 bidirectional, 8 differential pairs)
- Up to 400 Gbps aggregate (112 Gbps PAM4)
- Compatible with all MSA QSFP pluggables
- Eye Speed[®] ultra low skew twinax cable (3.5 ps/m max)

FLYOVER[®] OSFP SYSTEM

- Up to 1600 Gbps aggregate (224 Gbps PAM4)
- 8 Channels (x8 bidirectional, 16 differential pairs)
- Belly-to-belly capable for maximum density
- Eye Speed Thinax[™] ultra low skew twinax cable (3.5 ps/m max) or Eye Speed[®] hyper low skew twinax (1.75 ps/m max)

FLYOVER[®] QSFP DOUBLE DENSITY

- 8 Channels (x8 bidirectional, 16 differential pairs)
- Up to 800 Gbps aggregate (112 Gbps PAM4)
- PCIe[®] 6.0/CXL[®] 3.2 capable
- Belly-to-belly capable for maximum density
- Backward compatible with QSFP and QSFP-DD modules
- Eye Speed[®] ultra low skew twinax or Eye Speed Thinax[™] twinax cable (3.5 ps/m max)

The PCIe[®] design mark is a registered trademark and/or service mark of PCI-SIG.

FLYOVER® SFP CABLE ASSEMBLY

FSFP	CABLE TYPE	CABLE LENGTH	END 2 OPTION
	-01 = 34 AWG, 92 Ω Thinax™ ultra low skew twinax cable, 2 pairs	-“XX.X” = Length in inches 04.0" (101.6 mm) minimum	-1 = ARM6-02 (AcceRate®) -2 = NVAC 2x1 (NovaRay®)

FSFP

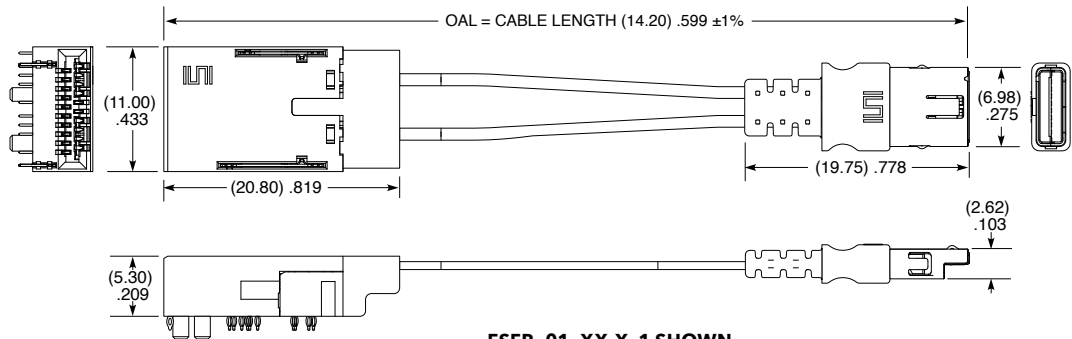

FSFP-01-XX.X-1 SHOWN

SFPC	STACK	NO. OF PORTS	EMI PANEL OPTION	OPTION	STYLE	HS-SFP	HEAT SINK STYLE	HEAT SINK HEIGHT	LIGHTPIPE
	-1 = Single High	-1 = One Port -2 = Two Ports	-S = Spring Fingers	(Leave blank for no light pipes) -LP = Light Pipe -N = No Heat Sink, Closed Top -H = Closed Top With Holes -A = Absorber	-F = Flyover®		-P1 = Pin (AL) -F1 = Front to Back Fin (AL)	-01 = (7.50 mm) .295" height -02 = (13.50 mm) .531" height (Not available with -F1)	(Leave blank for no light pipe) -LP = Light Pipe

SFPC-F



NO. OF PORTS	A	B	C
-1	(16.16) .636	(15.10) .594	(14.25) .561
-2	(30.41) 1.197	(29.35) 1.156	(28.50) 1.122

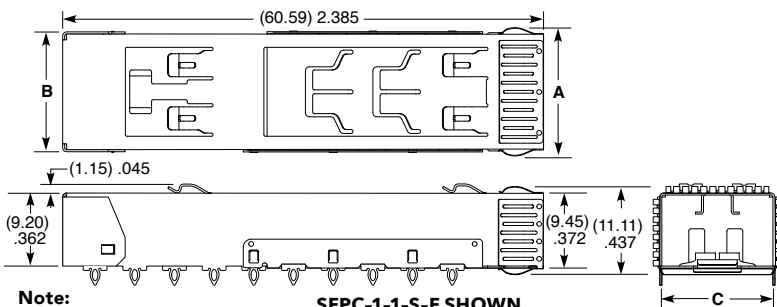

SFPC-1-1-S-F SHOWN

Note:
Some sizes, styles and options are non-standard, non-returnable.

HS-SFP

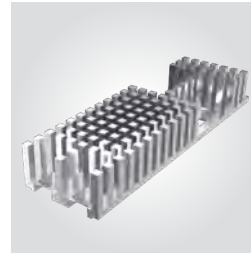

HEAT SINK HEIGHT	A
-01	(7.50) .295
-02	(13.50) .531

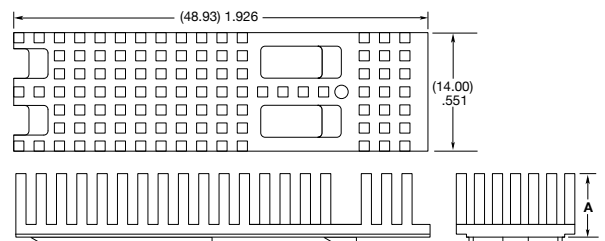

HS-SFP-P1-01 SHOWN

FOSFP	SIGNAL INTEGRITY	CABLE TYPE	CABLE LENGTH	END 2 OPTION
-------	------------------	------------	--------------	--------------

-1
= Up to 112 Gbps
PAM4 per differential pair

-01
= 34 AWG, 92 Ω Thinax™ ultra low skew twinax cable, 16 pairs

-"XX.X"
= Length in inches
(See chart for minimum)

-1
= ARC6-16
(AcceleRate[®])

-2
= NVAC 2x2
(NovaRay[®])

-3
= CPC-16
(Si-Fly[®] LP)

FOSFP-1
Panel Cage:
OSFPC
Heat Sink:
HS-OSFP



END 2 OPTION	CABLE LENGTH (Minimum in Inches)
-1	05.0" (127.0)
-2	05.0" (127.0)
-3	07.0" (177.8)

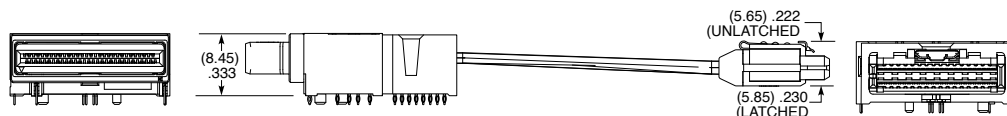
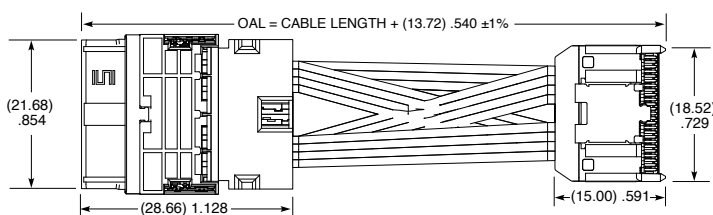

FOSFP-1-01-XX.X-1 SHOWN

Note:
Some sizes, styles and options are non-standard, non-returnable.

FOSFP	SIGNAL INTEGRITY	CABLE TYPE	CABLE LENGTH	END 2 OPTION
-------	------------------	------------	--------------	--------------

-2
= Up to 224 Gbps
PAM4 per differential pair

-01
= 32 AWG, 92 Ω Thinax™ ultra low skew twinax cable, 16 pairs

-"XX.X"
= Length in inches
06.0" (152.4 mm) minimum

-1
= SFNC Vertical
(Si-Fly[®] HD Near-Chip)

-3
= SFCC Right-Angle
(Si-Fly[®] HD Co-Packaged)

FOSFP-2
Panel Cage:
OSFPC
Heat Sink:
HS-OSFP



PRELIMINARY

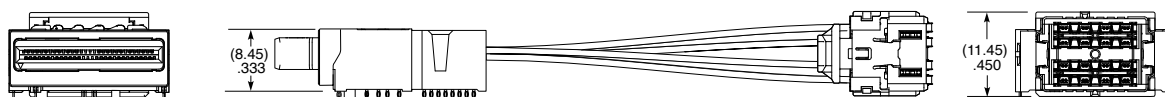
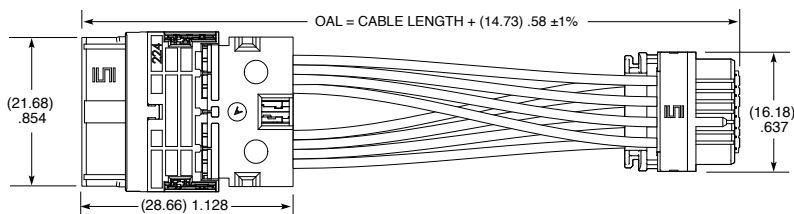

FOSFP-2-01-XX.X-1 SHOWN

Note:
Some sizes, styles and options are non-standard, non-returnable.

FLYOVER® OSFP CAGE & HEAT SINK

OSFPC	-	STACK	-	NUMBER OF PORTS	-	EMI PANEL OPTION	-	FLYOVER®
--------------	---	--------------	---	------------------------	---	-------------------------	---	-----------------

-1
=Single Stack

-1
= One Port

-S
= Spring Fingers

-F
= Flyover®

-6
= Six Ports

OSFPC
Use With:
FOSFP-1,
FOSFP-2,
HS-OSFP

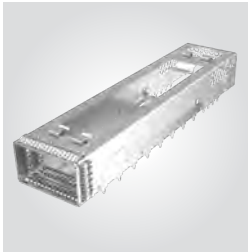

PRELIMINARY

NO OF PORTS	A	B	C
-1	(25.19) .992	(24.10) .949	(23.23) .915
-6	(141.34) 5.565	(140.25) 5.522	(139.38) 5.487

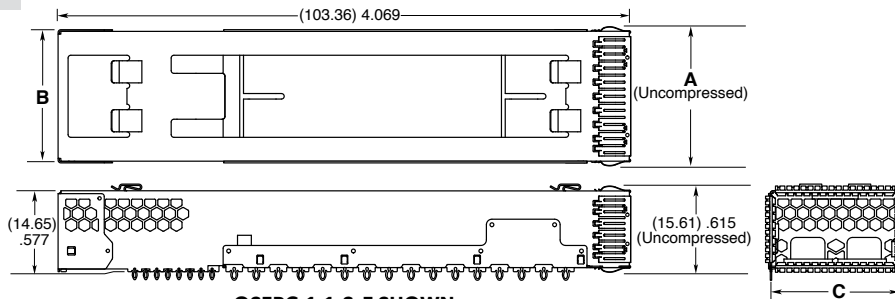

Note:
Some sizes, styles and options are non-standard, non-returnable.

HS-OSFP	-	HEAT SINK STYLE	-	HEAT SINK HEIGHT
----------------	---	------------------------	---	-------------------------

-1
=Zipper Fin

-1
= (5.40 mm) .213" height

-2
=Extruded Fin

-2
= (12.40 mm) .488" height

HS-OSFP
Use With:
FOSFP-1,
FOSFP-2,
OSFPC



PRELIMINARY

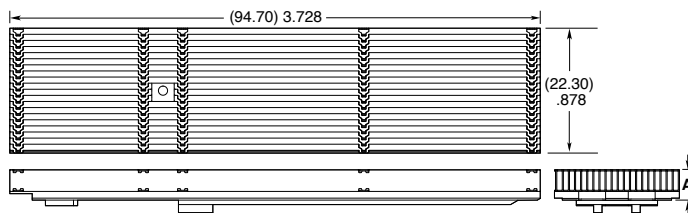

HEAT SINK HEIGHT	A
-1	(5.40) .213
-2	(12.40) .488

Note:
Some sizes, styles and options are non-standard, non-returnable.

FLYOVER® QSFP DOUBLE DENSITY CABLE ASSEMBLY

FQSFP - D8 - CABLE TYPE - FOOTPRINT - CABLE LENGTH - END 2 OPTION

FQSFP-D8



-03
= 34 AWG, 92 Ω
ultra low skew
twinax cable, 16 pairs

-05
= 34 AWG, 92 Ω
Thinax™ ultra low skew
twinax cable, 16 pairs

-A
= Primary

-B
= Secondary
(Belly-to-Belly only)

-"XX.X"
= Length in inches
06.0" (152.4 mm) min.
(-1 & -2 End 2 options)
07.0" (177.8 mm) min.
(-3 End 2 option)

-1
= ARC6-16
(AcceleRate®)

-2
= NVAC 2x2
(NovaRay®)

-3
= CPC
(Si-Fly® LP)

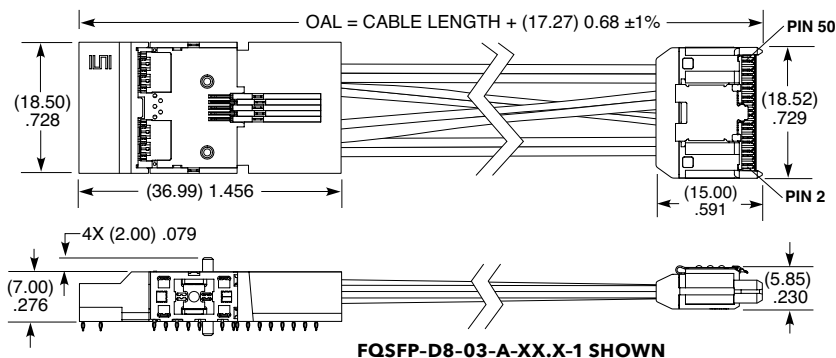

OTHER SOLUTIONS

400G/56 Gbps PAM4 double density cable assembly; visit samtec.com?fqsfp-dd

PRESS-FIT TOOLING

CAT-PT-FQSFP-DD-01
For more information, visit www.samtec.com/tooling

QSFP - D8 - STACK - NO. OF PORTS - OPTION - STYLE

QSFP-D8

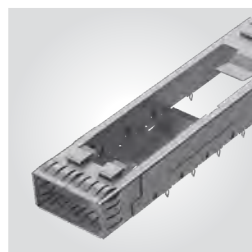

-1
= Single Stack

-1
= One Port

-S
= Spring Fingers

-F
= Flyover®

-2
= Two Ports

-3
= Three Ports

PRESS-FIT TOOLING

CAT-PT-FQSFP-03-XX
For more information, visit www.samtec.com/tooling

NO. OF PORTS	A	B	C
-1	(20.96) .825	(19.87) .782	(19.00) .748
-2	(39.96) 1.573	(38.87) 1.530	(38.00) 1.496
-3	(58.96) 2.321	(57.87) 2.278	(57.00) 2.244

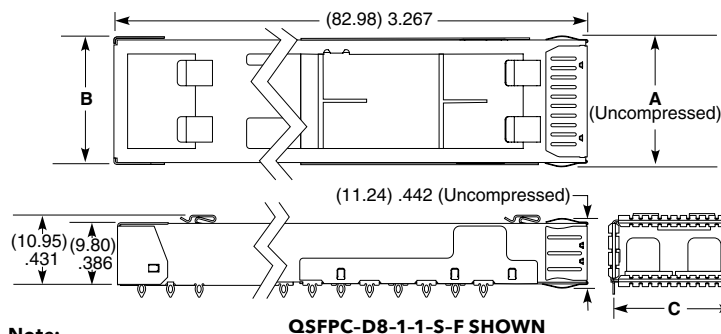

Note:
Some sizes, styles and options are non-standard, non-returnable.

HS-QSFP - D8 - HEAT SINK HEIGHT

HS-QSFP-D8

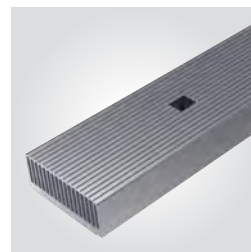

-1
= (6.20 mm) .244" height

-2
= (12.00 mm) .472" height

HEAT SINK HEIGHT	A
-1	(6.20) .244
-2	(12.00) .472

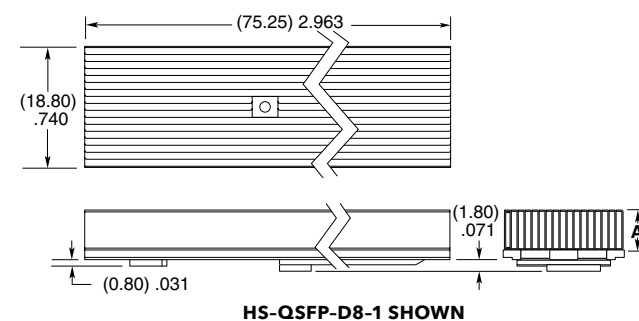

FLYOVER® QSFP CABLE ASSEMBLY

FQSFP	LEAD STYLE	CABLE LENGTH	PLATING	CONTACT TYPE	END OPTION
-------	------------	--------------	---------	--------------	------------

-01
= 10 Low-Speed,
8 Pairs High-Speed

-"XX.X"
= Length in inches
04.0" (101.6 mm)
minimum

-L
= 10 μ" (0.25 μm)
Gold over
50 μ" (1.27 μm)
Ni on contact area,
Matte Tin on tail

-PF
= Press-fit

-3
= ECUE
(FireFly™)

-4
= ARC6-8
(AcceleRate®; 34 AWG,
100 Ω Thinax™ ultra low
skew twinax cable)

-5
= ARC6-8
(AcceleRate®; 34 AWG,
100 Ω ultra low skew
twinax cable)

FQSFP

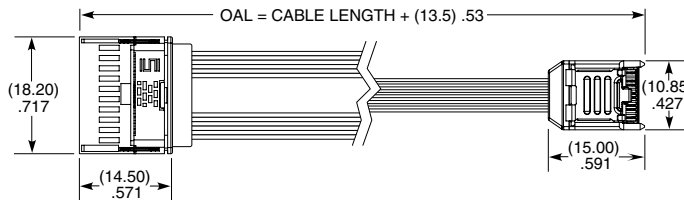

PRESS-FIT TOOLING

CAT-PT-FQSFP-01
For more information, visit
www.samtec.com/tooling

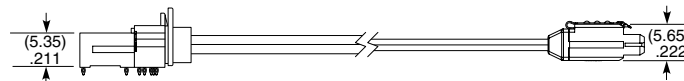

FQSFP-01-XX.X-L-PF-4 SHOWN

QSFP	CAGE OPTION	NUMBER OF PORTS	EMI PANEL OPTION	OPTION	FLYOVER®
------	-------------	-----------------	------------------	--------	----------

-1
= Single Stack

-1
= One Port

-S
= Spring
Fingers

(Leave blank for no Light Pipe)

(Leave blank for no Flyover®)

-2
= Two Ports

-LP
= Light Pipe
(1 & 4 ports only)

-F
= Flyover®

-4
= Four Ports

-N
= No heat sink closed top
(Not available with -LP)

QSFP

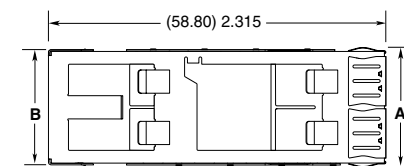
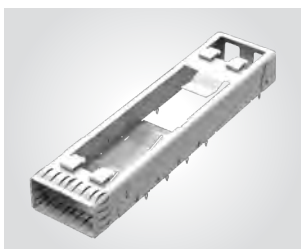

NO. OF PORTS	A	B	C
-1	(20.62) .812	(19.85) .781	(19.00) .748
-2	(39.62) 1.560	(38.85) 1.530	(38.00) 1.496
-4	(77.62) 3.056	(76.85) 3.026	(76.00) 2.992

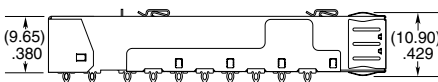

QSFP-1-1-S-F SHOWN

PRESS-FIT TOOLING

CAT-PT-FQSFP-03-XX
For more information, visit
www.samtec.com/tooling

HEAT SINKS

PART NUMBER	HEAT SINK HEIGHT
HS-QSFP-P1-01	(4.20 mm) .165"
HS-QSFP-P1-02	(6.50 mm) .256"
HS-QSFP-P1-03	(13.50 mm) .531"
HS-QSFP-P1-04	(1.50 mm) .059"

LIGHT PIPES

PART NUMBER	NO. OF PORTS
LP-FQSFP-01	1 pipe
LP-FQSFP-02	2 pipes
LP-FQSFP-04	4 pipes

View complete specifications at samtec.com/LP-FQSFP

Notes:

Some sizes, styles and options are non-standard, non-returnable.

For Light Pipe, add -LP to the end of part number.
View complete specifications at samtec.com/HS-QSFP

NOVARAY[®] I/O

EXTREME PERFORMANCE PANEL MOUNT I/O ASSEMBLIES

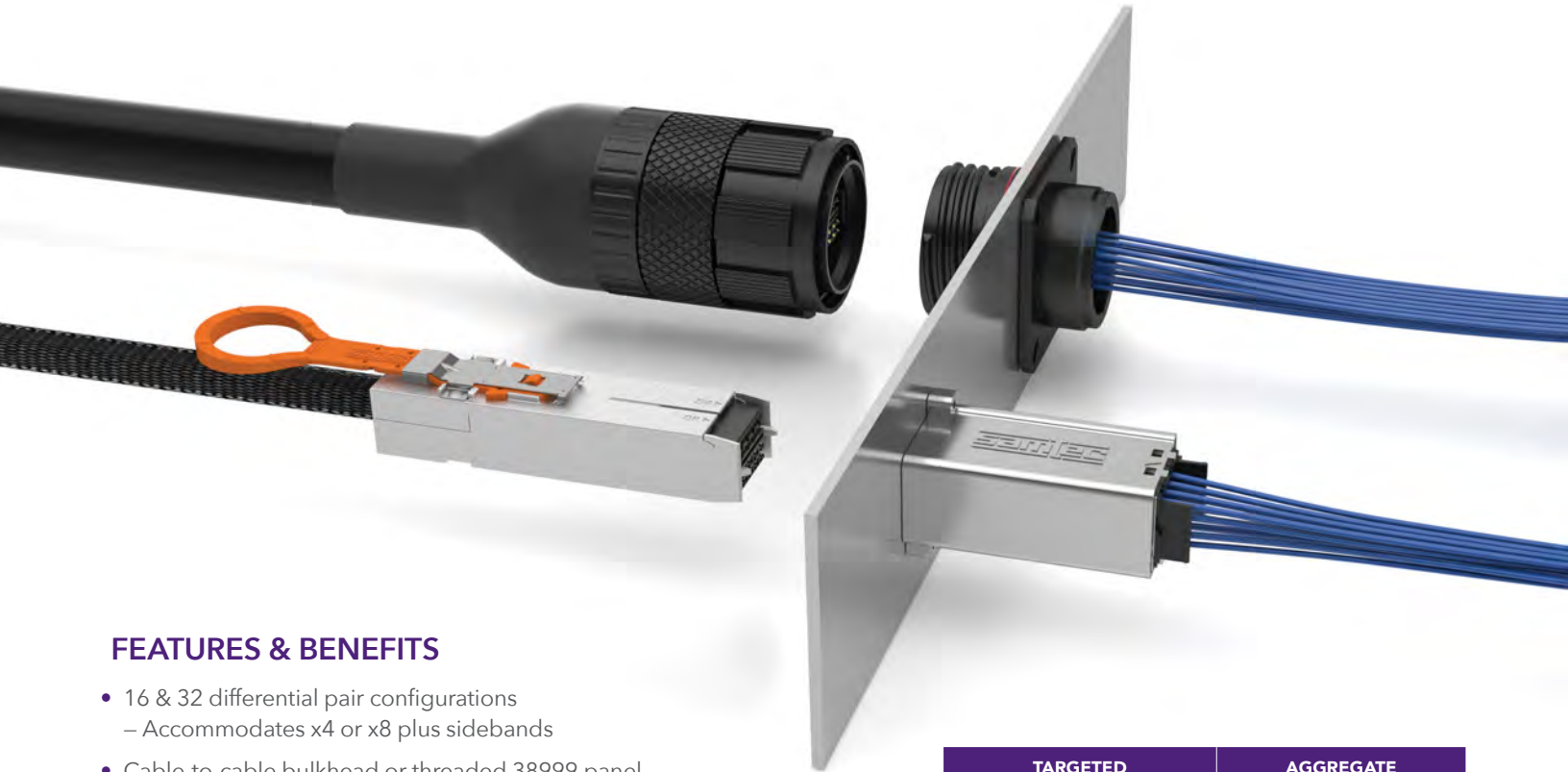

FEATURES & BENEFITS

- 16 & 32 differential pair configurations
– Accommodates x4 or x8 plus sidebands
- Cable-to-cable bulkhead or threaded 38999 panel connection using Flyover[®] Cable Technology
- Rugged 38999 shell is salt fog resistant to 48 hours and IP67 rated for dust and water applications
- Eye Speed[®] ultra low skew twinax cable
- Single-ended micro coax options also available
- Full external EMI shielding
- Multiple end 2 high-speed connector options on internal cable

PAM 4
128
G b p s

PCI EXPRESS
PCIe[®] 7.0 CAPABLE

TARGETED CONFIGURATIONS	AGGREGATE DATA RATE
8 Pair (In Development)	1024 Gbps
16 Pair	2048 Gbps
32 Pair	4096 Gbps
x4 (8 Pair + PCIe [®] Sidebands)	512 Gbps
x8 (16 Pair + PCIe [®] Sidebands)	1024 Gbps

KEY SPECIFICATIONS

SERIES	CABLE	SIGNAL ROUTING	INSULATOR MATERIAL	CONTACT MATERIAL	PLATING	OPERATING TEMP RANGE	CURRENT RATING	VOLTAGE RATING
NVACE	34 or 28 AWG ultra low skew twinax; 34 AWG ThinSE™ micro coax	100 Ω Differential & 50 Ω Single-Ended	High Temp Thermoplastic	Copper Alloy	Au over 50 μ" (1.27 μm) Ni	-40 °C to +105 °C	1.17 A (4 row)	211 VAC/ 298 VDC
NVACP	34 AWG ultra low skew twinax; 34 AWG Thinax™ twinax; 34 AWG ThinSE™ micro coax	92 Ω & 100 Ω Differential, 50 Ω Single-Ended						
NVA3E	34 or 28 AWG ultra low skew twinax	100 Ω Differential	Black LCP	Copper Alloy	Au over 50 μ" (1.27 μm) Ni	Testing Now!	Testing Now!	Testing Now!
NVA3P	34 AWG ultra low skew twinax							

EXTREME PERFORMANCE PANEL MOUNT CABLE

NVACP	SIGNAL TYPE	CABLE STYLE	ROWS	CABLE LENGTH	END 2	PIN OUT	SPEED
-------	-------------	-------------	------	--------------	-------	---------	-------

-DP
= Differential pairs
(-1, -3 or -7 cable only)

-SE*
= Single-ended
(-8 cable only)

-DS*
= Mixed -DP & -SE
(-1, -3 or -7 cable for DP; -8 cable for -SE)

-1
= 34 AWG, 100 Ω
ultra low skew
twinax cable

-3
= 34 AWG, 92 Ω
ultra low skew
twinax cable

-7
= 34 AWG, 92 Ω
Thinax™ ultra
low skew
twinax cable

-8
= 34 AWG, 50 Ω
ThinSE™ micro
coax cable

-4
= 4 rows

-8
= 8 rows

-XX.X
= Length in inches
06.0"
(152.4 mm)
minimum

-A
= 1 ARC6
(34 AWG
100 Ω
twinax only)

-B
= 1 NVAC

-1
= Pin A01
to Pin A01

-4
= Pin A01
to Pin AN
(N equals
last position)

(Differential twinax
pairs only)

-1
= Up to 128G
PAM4

*Contact HDRGroup@samtec.com for applications requiring -SE or -DS options

NVACP
Cable Mates:
NVACE
Panel Cage:
NVC



Notes:
Cable lengths longer than 40.00" (1 meter) are not supported with S.I. test data.

Some sizes, styles and options are non-standard, non-returnable.

-8 CABLE PRELIMINARY

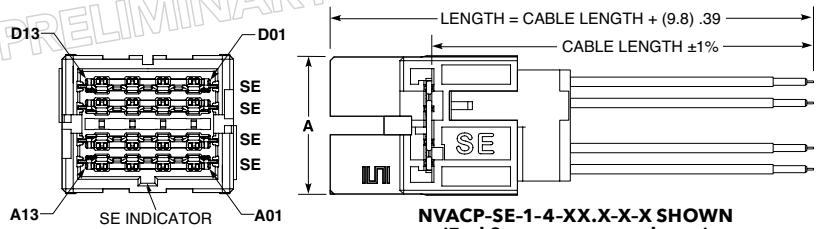

ROW	A
-4	(12.95) .510
-8	(20.95) .825

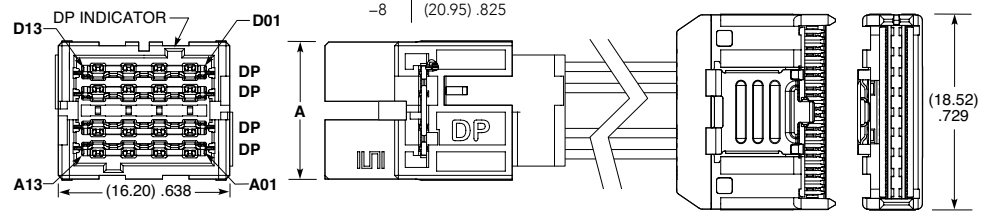

ARC6 CONNECTOR SHOWN

DIE CAST PANEL CAGE

View complete specifications at: samtec.com?NVACP

NVC	NO. OF PORTS	ROWS	PACKAGING
-----	--------------	------	-----------

-1
= 1 Port
(4 row only)

-2
= 2 Ports
(8 row only)

-4
= 4 Ports
(8 row only)

-04
= 4 rows

-08
= 8 rows

-TY
= Trays

NVC
Use with:
NVACP, NVACE



ROW	A	B	C	D
-04	(16.55) .652	(23.35) .919	(15.36) .605	(19.56) .770
-08	(24.55) .967	(31.35) 1.234	(23.36) .920	(27.56) 1.085

Note:
Some sizes, styles and options are non-standard, non-returnable.

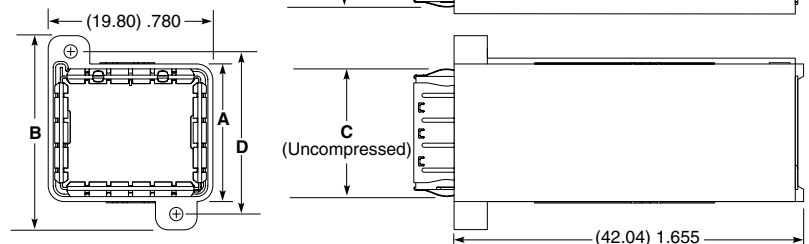

View complete specifications at: samtec.com?NVC

EXTREME PERFORMANCE I/O CABLE

NVACE	SIGNAL TYPE	CABLE TYPE	ROWS	CABLE LENGTH	END 2	PIN OUT	SPEED
	-DP = Differential pairs (-1 or -5 cable only)	-1 = 34 AWG, 100 Ω ultra low skew twinax	-4 = 4 rows -8 = 8 rows	-X.X = Length in meters 0.5 meters (19.69") minimum	-A = NVACE	-1 = Pin A01 to Pin A01 -4 = Pin A01 to Pin N01	(Differential twinax pairs only) -1 = Up to 128G PAM4
	-SE* = Single-ended (-9 cable only)	-5 = 28 AWG, 100 Ω ultra low skew twinax					
	-DS* = Mixed -DP & -SE (-1 or -5 cable for -DP; -9 cable for -SE)	-9 = 34 AWG, 50 Ω ThinSE™ micro coax					

*Contact HDRGroup@samtec.com for applications requiring -SE or -DS options

NVACE

Cable Mates:
NVACP
Panel Cage:
NVC

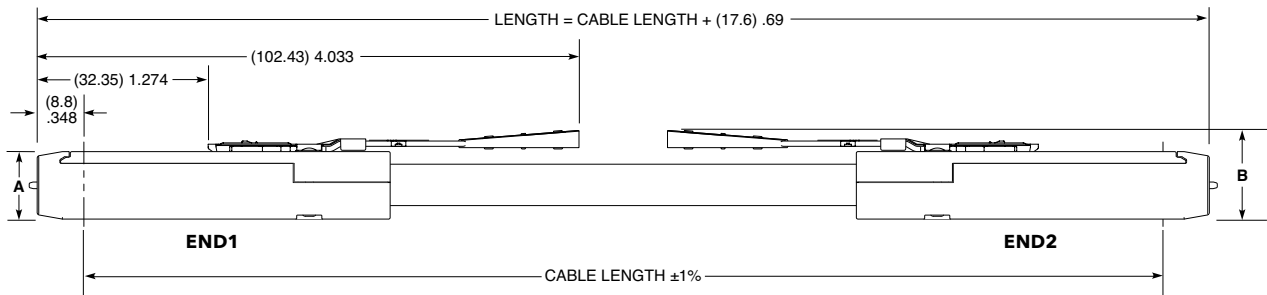

NVACE-XX-X-4-X-X-A-X-1 SHOWN

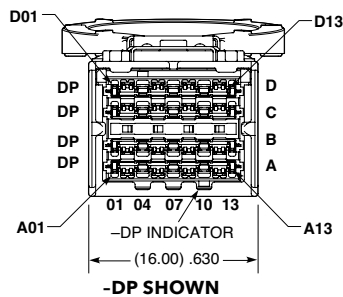

ROW	A	B
-4	(12.75) .502	(17.00) .669
-8	(20.75) .817	(25.00) .984

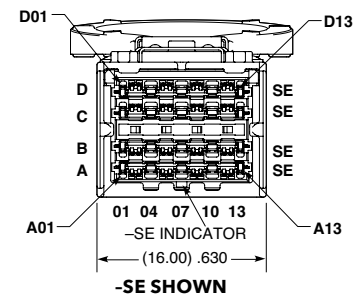

Notes:
Cable lengths longer than 3 meters (118") are not supported with S.I. test data.

Some sizes, styles and options are non-standard, non-returnable.

View complete specifications at: samtec.com?NVACE

RUGGED 38999 I/O CABLE

NVA3E	SIGNAL TYPE	CABLE TYPE	SHELL SIZE	CABLE LENGTH	END 2	PIN OUT	SPEED	FINISH	IP SEALING
	-DP = Differential (twinax pairs only)	-1 = 34 AWG, 100 Ω ultra low skew twinax	-19 = 4 rows	(Standard lengths in meters) -0.5 = (0.5 m) 19.69" Cable -1.0 = (1.0 m) 39.37" Cable -2.0 = (2.0 m) 78.74" Cable -3.0 = (3.0 m) 118.11" Cable	-A = NVA3E	-1 = Pin A01 to Pin A01 -4 = Pin A01 to Pin N	-1 = Up to 128G PAM4	-Z = Black Zinc Nickel	(Leave blank for no sealed) -S = Sealed

NVA3E
Cable Mate:
NVA3P



Notes:
Cable lengths longer than 3 meter (118.00") are not supported with S.I. test data.

Some sizes, styles and options are non-standard, non-returnable.

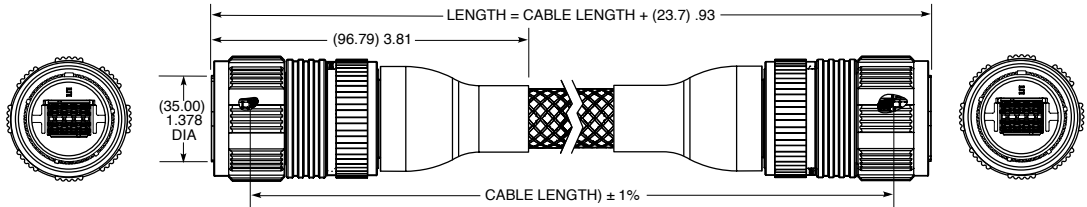

NVA3E-DP-X-19-X.X-A-X-1-Z-X SHOWN

View complete specifications at: samtec.com?NVA3E

RUGGED 38999 PANEL MOUNT CABLE

NVA3P	SIGNAL TYPE	CABLE TYPE	SHELL SIZE	CABLE LENGTH	END 2	PIN OUT	SPEED	FINISH	IP SEALING
	-DP = Differential (twinax pairs only)	-1 = 34 AWG, 100 Ω ultra low skew twinax	-19 = 4 rows	(Standard lengths in inches) -06.0 = (152.4 mm) 6.0" Cable -10.0 = (254.0 mm) 10.0" Cable -12.0 = (304.8 mm) 12.0" Cable -20.0 = (508.0 mm) 20.0" Cable	-A = ARC6 -B = NVAC	-1 = Pin A01 to Pin A01 -4 = Pin A01 to Pin AN (N equals last position)	-1 = Up to 128G PAM4	-Z = Black Zinc Nickel	(Leave blank for no sealed) -S = Sealed

NVA3P
Cable Mate:
NVA3E



Notes:
Cable lengths longer than 1 meter (40.00") are not supported with S.I. test data.

Some sizes, styles and options are non-standard, non-returnable.

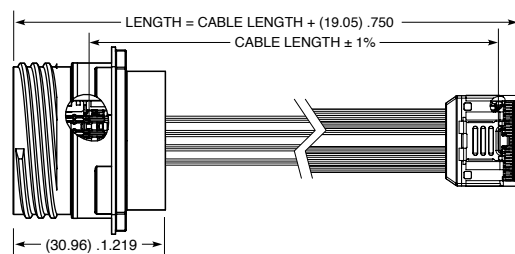
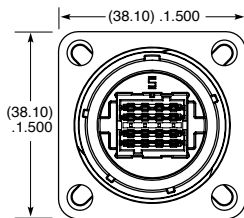

NVA3P-DP-1-19-XX.X-A-X-1-Z-X SHOWN

View complete specifications at: samtec.com?NVA3P

ExaMAX[®] I/O

SHIELDED, HIGH-DENSITY I/O CABLE SYSTEM

(2.00 mm) .0787" PITCH

PAM4

64
Gbps

FEATURES & BENEFITS

- Fully shielded external cable and cage for EMI protection
- Supports 64 Gbps PAM4 (32 Gbps NRZ) applications
- PCIe[®] 6.0/CXL[®] 3.2 capable
- Rugged pull latch for mating/unmating
- Single port cage designed for use with ExaMAX[®] right-angle board connector (EBTM-RA)
- 30 and 34 AWG Eye Speed[®] ultra low skew twinax
- 24 to 48 pairs (4 and 6 pairs; 6 and 8 columns)
- In Development: Cable-to-cable bulkhead panel connection for increased performance to 112 Gbps PAM4



Cable to right-angle panel mount

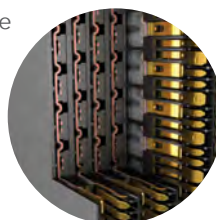

Staggered differential pair design

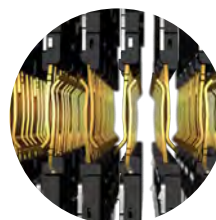

Two reliable points of contact at all times



Wafer design reduces crosstalk

KEY SPECIFICATIONS (EBCE/EBTC)

CABLE	INSULATOR MATERIAL	CONTACT MATERIAL	PLATING	OPERATING TEMP RANGE	CURRENT RATING	VOLTAGE RATING
30 & 34 AWG ultra low skew twinax	LCP	Copper Alloy	Au over 50 μ" (1.27 μm) Ni	Testing Now!	Testing Now!	Testing Now!

PCI-SIG[®], PCI Express[®] and the PCIe[®] design marks are registered trademarks and/or service marks of PCI-SIG.

(2.00 mm) .0787" PITCH • SHIELDED PANEL MOUNT CABLE

EBCE	GAUGE/ SIGNAL MAP	PAIRS PER COLUMN	COLUMNS	END 1 LATCH	END 1 PIN	CABLE LENGTH	END 2 LATCH	END 2 PIN
	-1 = 34 AWG 100 Ω, Tx to Rx Signal Map	-4 = 4 Pairs	-06, -08	-LU = Latch Up	-1 = Standard	- "XX" = Length in Inches 12" (304.8 mm) minimum	-LU = Latch Up	-1 = Standard
	-2 = 30 AWG 100 Ω, Tx to Rx Signal Map	-6 = 6 Pairs						
	-3 = 34 AWG 100 Ω, 1:1 Signal Map							
	-4 = 30 AWG 100 Ω, 1:1 Signal Map							

PRELIMINARY

NO. OF COLUMNS	B
-06	(18.40) .724
-08	(22.40) .882

EBCE
Mates With:
EBTM-RA/EBTC

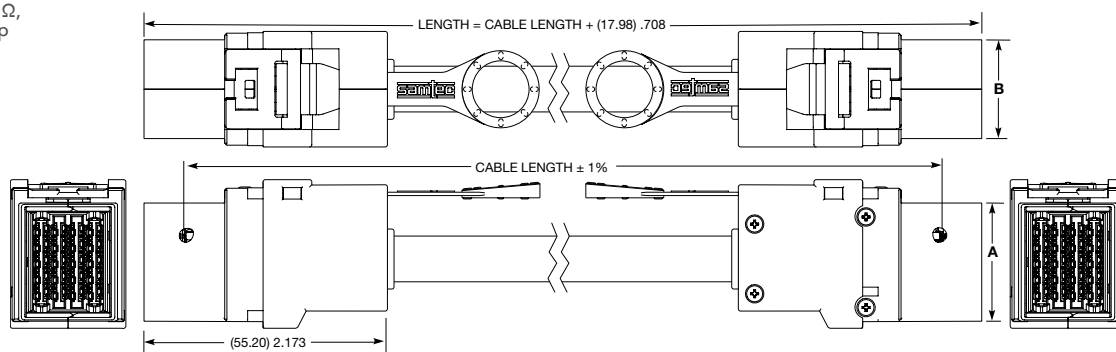

EBCE-X-4-08-LU-1-XX-LU-1 SHOWN

PAIRS	A
-4	(26.80) 1.055
-6	(34.00) 1.339

Notes:
Cable lengths longer than 40.00" (1 meter)
are not supported with S.I. test data.

Some sizes, styles and options
are non-standard, non-returnable.

View complete specifications at: samtec.com?EBCE

DIE CAST PANEL CAGE

EBTC	PAIRS PER COLUMN	COLUMNS	PORT SIZE
	-4 = 4 Pairs	-06, -08	-1
	-6 = 6 Pairs		

PRELIMINARY

EBTC
Use With:
EBTM-RA, EBCE



NO. OF COLUMNS	E
-06	(30.80) 1.213
-08	(34.80) 1.370

PAIRS	A	B	C	D
-4	(35.20) 1.386	(26.25) 1.033	(50.00) 1.969	(12.30) .484
-6	(42.40) 1.669	(33.45) 1.317	(57.20) 2.252	(19.50) .768

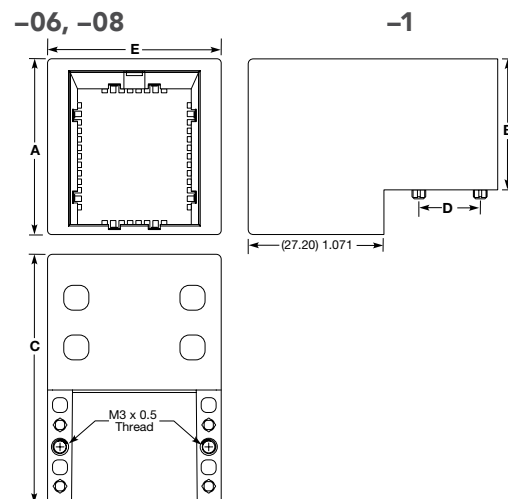

EBTC-4-08-1 SHOWN

Note:
Some sizes, styles and
options are non-standard,
non-returnable.

View complete specifications at: samtec.com?EBTC

FLYOVER® ASSEMBLIES BY SERIES & CABLE TYPE

USING EYE SPEED® CABLE TECHNOLOGY

FAMILY	SERIES	DIFFERENTIAL PAIR (-DP)			SINGLE ENDED (-SE)	MIXED SIGNALING (-DP & -SE)	PAGE NO.
		Ultra Low Skew Twinax	Thinax™	Hyper Low Skew Twinax	ThinSE™		
AcceleRate®	ARC6	ARC6	ARC6		ARC6	ARC6	117
AcceleRate® Boost	ABC6		ABC6				116
AcceleRate® Mini	ARM6	ARM6	ARM6				119
AcceleRate® HP	ARP6		ARP6		ARP6	ARP6	115
AcceleRate® HP Double Density	ART6		ART6				114
Si-Fly® LP	CPC	CPC	CPC				121
Si-Fly® HD Co-Packaged	SFCC			SFCC			123
Si-Fly® HD Near-Chip	SFNC			SFNC			124
ExaMAX®	EBCF	EBCF	EBCF		EBCF		90
ExaMAX®	EBCM	EBCM	EBCM		EBCM		89
ExaMAX® I/O	EBCE	EBCE					109
Flyover® OSFP 112	FOSFP-1		FOSFP-1				100
Flyover® OSFP 224	FOSFP-2		FOSFP-2	FOSFP-2			100
Flyover® QSFP	FQSFP	FQSFP	FQSFP				103
Flyover® QSFP Double Density 400	FQSFP-DD	FQSFP-DD	FQSFP-DD				102
Flyover® QSFP Double Density 800	FQSFP-D8	FQSFP-D8	FQSFP-D8				102
Flyover® SFP112	FSFP		FSFP				99
NovaRay® I/O 38999	NVA3E	NVA3E					107
NovaRay® I/O 38999	NVA3P	NVA3P					107
NovaRay®	NVAC	NVAC	NVAC				113
NovaRay® I/O	NVACE	NVACE			NVACE	NVACE	106
NovaRay® I/O	NVACP	NVACP	NVACP		NVACP	NVACP	105
NovaRay® Backplane*	NVCM-RA		NVCM-RA		NVCM-RA		85
NovaRay® Backplane*	NVCF		NVCF		NVCF		84

RELEASED

IN DEVELOPMENT

*30 AWG power cable in development



HIGH-SPEED CABLE MID-BOARD SYSTEMS

FLYOVER® TECHNOLOGY • UP TO 224 Gbps PAM4 PER CHANNEL • VARIETY OF END OPTIONS

112-113

NOVARAY® EXTREME DENSITY & PERFORMANCE SYSTEM (NVAC, NVAM-CT)

NOVARAY®

A blue multi-strand cable with a black connector and a silver metal housing component.

114-115

ACCELERATE® HP HIGH-PERFORMANCE CABLE SYSTEM (ARP6, APF6-L)

ACCELERATE® HP

A blue multi-strand cable with a black connector and a silver metal housing component.

116-117

ACCELERATE® SLIM CABLE SYSTEM (ARC6, ARF6)

ACCELERATE®

A blue multi-strand cable with a black connector and a silver metal housing component.

118-119

ACCELERATE® MINI EXTREME PERFORMANCE MINI FORM FACTOR (ARM6, AMF6)

ACCELERATE® mini

A blue multi-strand cable with a black connector and a silver metal housing component.

120-121

SI-FLY® LP LOW PROFILE, HIGH-DENSITY CABLE SYSTEM (CPC, CPI)

SI-FLY® LP

A blue multi-strand cable with a black connector and a silver metal housing component.

122-124

SI-FLY® HD 224 GBPS PAM4 CO-PACKED AND NEAR CHIP SYSTEMS (SFCC, SFCM, SFNC, SFNM)

SI-FLY® HD

A blue multi-strand cable with a black connector and a silver metal housing component.

125-126

GENERATE® HIGH-SPEED EDGE CARD SYSTEMS (GC6, GC6-RF)

GENERATE®

A blue multi-strand cable with a black connector and a green edge card component.

EXTREME HIGH-SPEED, HIGH-DENSITY CABLE

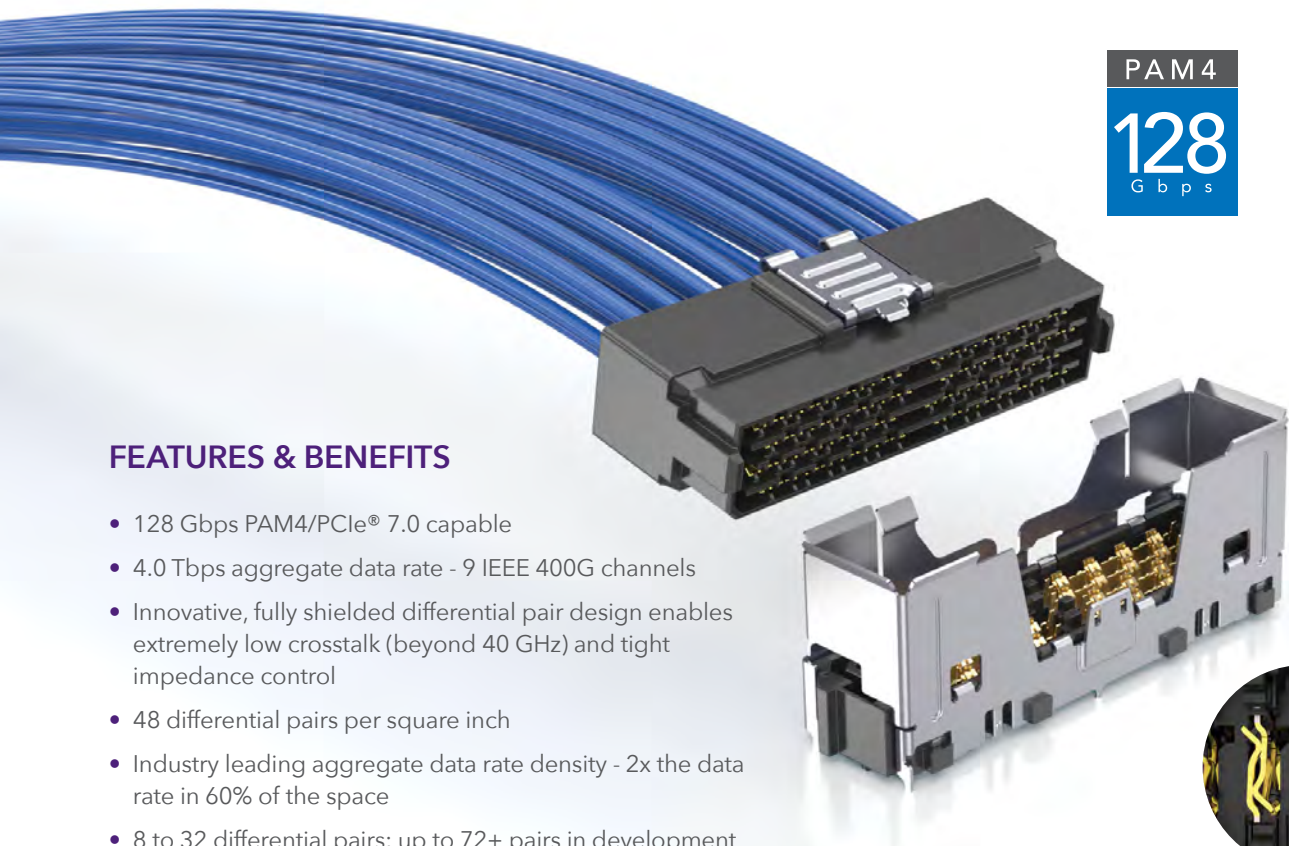

PAM4
128
Gbps

FEATURES & BENEFITS

- 128 Gbps PAM4/PCIe[®] 7.0 capable
- 4.0 Tbps aggregate data rate - 9 IEEE 400G channels
- Innovative, fully shielded differential pair design enables extremely low crosstalk (beyond 40 GHz) and tight impedance control
- 48 differential pairs per square inch
- Industry leading aggregate data rate density - 2x the data rate in 60% of the space
- 8 to 32 differential pairs; up to 72+ pairs in development
- Panel I/O solution available with extended EMI shielding (NVACE/NVACP) or rugged 38999 shell (NVA3E/NVA3P)



Two reliable points of contact guaranteed

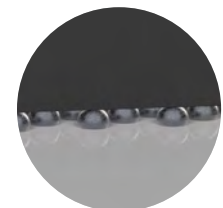

BGA attach for density and optimized trace breakout region

Aggregate Data Rate (NRZ)						
1024 Gbps	1536 Gbps	2048 Gbps	3072 Gbps	4096 Gbps	9216 Gbps*	
1 Bank		2 Bank			3 Bank*	
2 Row	3 Row	4 Row	2 Row	3 Row	4 Row	6 Row*
8 Pairs	12 Pairs	16 Pairs		24 Pairs	32 Pairs	72 Pairs*
						*In development

KEY SPECIFICATIONS (NVAC/NVAM-CT)

CABLE	INSULATOR MATERIAL	CONTACT MATERIAL	PLATING	OPERATING TEMP RANGE	CURRENT RATING	VOLTAGE RATING
34 AWG, 92 Ω & 100 Ω ultra low skew twinax cable 34 AWG, 92 Ω Thinax™ ultra low skew twinax cable	LCP	Copper Alloy	Au over 50 μ" (1.27 μm) Ni	-40 °C to +125 °C	2.0 A per pin (signal) 9.9 A per pin (ground)	180 VAC/255 VDC

PCI-SIG[®], PCI Express[®] and the PCIe[®] design marks are registered trademarks and/or service marks of PCI-SIG.

EXTREME PERFORMANCE & DENSITY SYSTEM

NVAC	STYLE	CABLE STYLE	NO. OF ROWS	NO. OF BANKS	CABLE LENGTH	01	PIN OUT	OPTION
------	-------	-------------	-------------	--------------	--------------	----	---------	--------

-DP
= 4 pairs per wafer

-1
= 34 AWG, 100 Ω ultra low skew twinax cable

-3
= 34 AWG, 92 Ω ultra low skew twinax cable

-5
= 34 AWG, 92 Ω Thinax™ ultra low skew twinax cable

-02
= 2 Rows

-03
= 3 Rows

-04
= 4 Rows

-1
= 1 Bank

-2
= 2 Banks

-"XX.X"
= Length in inches (152.4 mm) 06.0" minimum

-1
= Pin A01 to Pin AN (N equals last position)

-L
= Latch

NVAC
Board Mates:
NVAM-CT



NO. OF BANKS	N	B
-1	16	(20.25) .797
-2	32	(36.25) 1.427

ROWS	A
-02	(4.40) .173
-03	(6.20) .244
-04	(8.00) .315

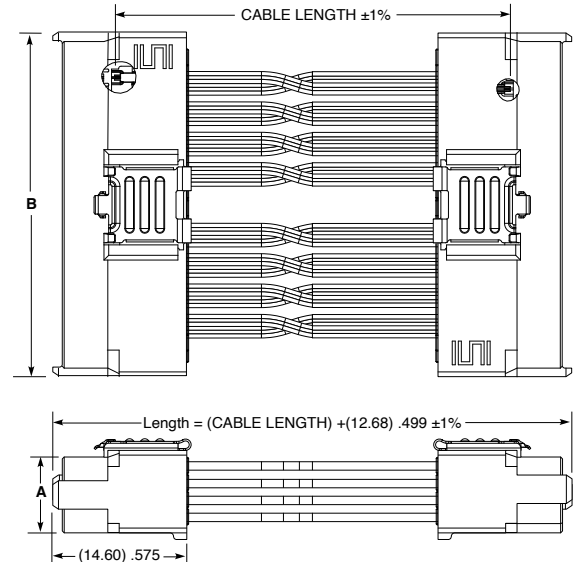

Notes:
Cable lengths longer than 40.00" (1 meter) are not supported with S.I. test data.

View complete specifications at: samtec.com?NVAC

NVAM	STYLE	NO. OF ROWS	NO. OF BANKS	02.0	PLATING OPTIONS	SOLDER TYPE	CT	"X"R
------	-------	-------------	--------------	------	-----------------	-------------	----	------

-DP
= 4 pairs per wafer

-02
= 2 Rows

-03
= 3 Rows

-04
= 4 Rows

-1
= 1 Bank

-2
= 2 Banks

-S
= 30 μ" (0.76 μm) Gold on contact area, Matte Tin on solder tail

-2
= Lead-Free Solder Charge

-TR
= Tape & Reel

-FR
= Full Reel Tape & Reel (must order max. quantity per reel; contact Samtec for quantity breaks)

NVAM-CT
Board Mates:
NVAC

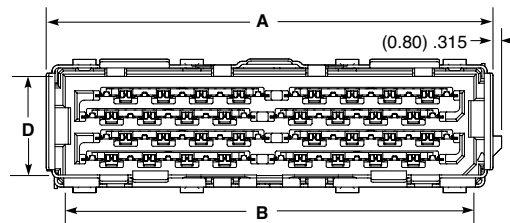

NO. OF BANKS	A	B	C
-1	(21.89) .862	(18.65) .734	(20.25) .797
-2	(37.89) 1.492	(34.65) 1.364	(36.25) 1.427

NO. OF ROWS	D	E	F
-02	(4.80) .189	(5.26) .207	(7.70) .303
-03	(6.60) .260	(7.06) .278	(9.50) .374
-04	(8.40) .331	(8.86) .348	(11.30) .445

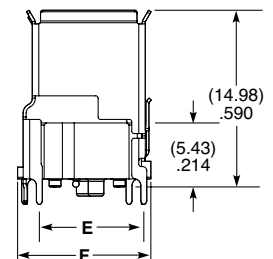
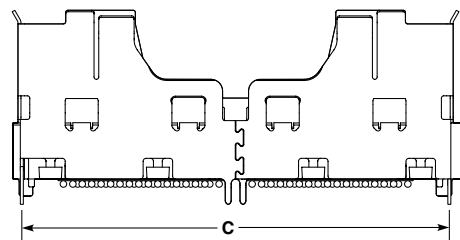

Note:
Some sizes, styles and options are non-standard, non-returnable.

View complete specifications at: samtec.com?NVAM-CT

ACCELERATE[®]HP

EXTREME DENSITY CABLE SYSTEM

(0.635 mm) .025" PITCH

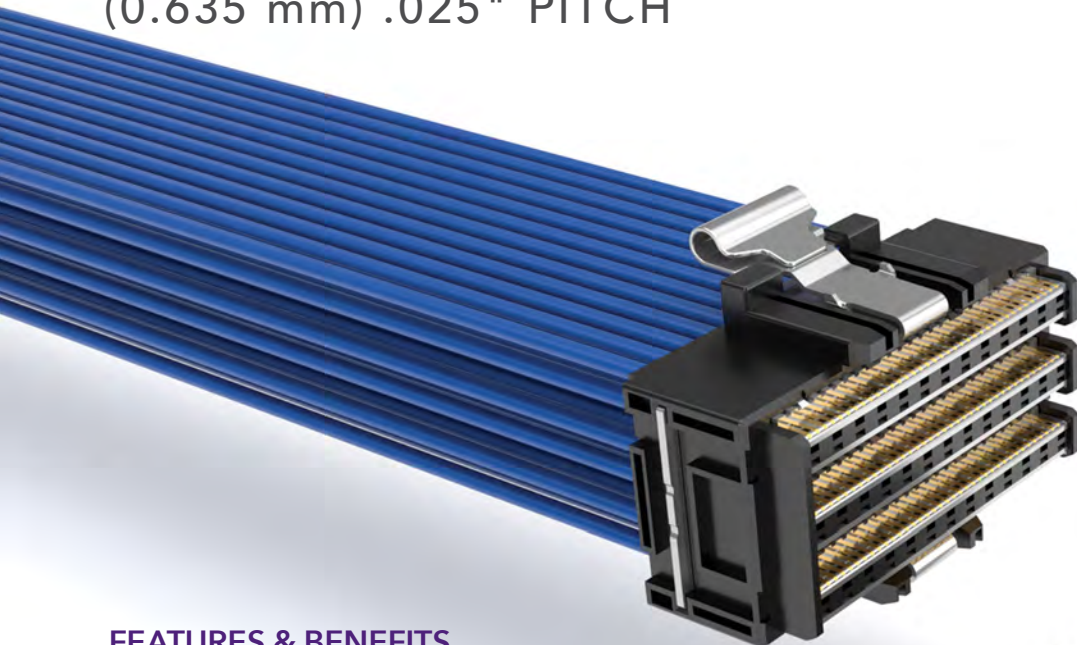

PAM4
112
G b p s

FEATURES & BENEFITS

- Industry's highest density 112G PAM4 cable system
- 0.635 mm contact pitch; 2.20 x 2.40 mm row-to-row pitch
- 4, 6 and 8 rows; 8 or 12 pairs per row
- Up to 96 Thinax™ ultra low skew twinax cable
- Single-ended micro coax configuration
 - 34 AWG ThinSE™ micro coax cables
 - 12 or 18 coax per row
 - Dedicated G-S-G-S-G layout for reduced crosstalk
- Right-angle mating connector
- 112 Gbps PAM4 double density direct-to-chip package solution with up to 144 differential pairs and Eye Speed Thinax™ ultra low skew twinax cable (ART6/ATF6); contact HDR@samtec.com for information
- Cable-to-cable solution in development



Locking for maximum density
(removal tool required)

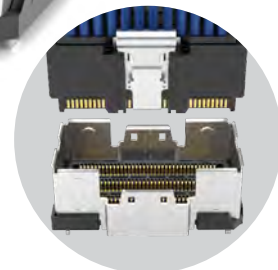

Squeeze latching
for quick disconnect

KEY SPECIFICATIONS (ARP6)

CABLE	INSULATOR MATERIAL	CONTACT MATERIAL	PLATING	OPERATING TEMP RANGE	CURRENT RATING	VOLTAGE RATING
34 AWG, 92 Ω Thinax™ ultra skew twinax cable	Black LCP	Copper Alloy	Au or Sn over 50 μ" (1.27 μm) Ni	-40 °C to +125 °C	1.3 A (6 pins powered)	165 VAC/233 VDC
34 AWG, 50 Ω ThinSE™ micro coax cable						

(0.635 mm) .025" • HIGH-DENSITY/PERFORMANCE CABLE

ARP6	STYLE	NO. OF POSITIONS	NO. OF ROWS	CABLE LENGTH	END 2 ORIENTATION	END 1 OPTION	END 2 OPTION
	-DP = 92 Ω Thinax™ ultra low skew twinax cable -SE = 50 Ω ThinSE™ micro coax cable -DS = Mixed -DP & -SE	Specify NO. OF POSITIONS from chart	-04 = Four Rows -06 = Six Rows -08 = Eight Rows	"XX.X" = Length in Inches 05.0" (127 mm) minimum	-T = Top -B = Bottom	-L = Squeeze Latch -T = Locking Tool -S = Single Latch (-04 row only; required for mating APF6-RA-S)	-L = Squeeze Latch -T = Locking Tool -S = Single Latch (-04 row only; required for mating APF6-RA-S)

ARP6 Board Mates:
APF6-L, APF6-T, APF6-S, APF6-RA*, APF6-RA-S

*APF6-RA requires APF6-C cage to mate with ARP6.

LENGTH = (CABLE LENGTH) + (7.1) .28 ±1%
CABLE LENGTH ±1%
(12.40) .488

ARP6-DP-037-06-XX.X-B-L-L SHOWN

NO. OF POSITIONS PER ROW	A	NO. OF ROWS	B	C
-025	(20.34) .801	-04	(12.54) .494	(18.58) .731
-037	(27.96) 1.101	-06	(17.14) .675	(23.39) .921
		-08	(21.74) .856	(27.99) 1.102

STYLE	NO. OF POSITIONS PER ROW	PINOUT ARRANGEMENT
-DP	-025	8 Differential Pairs Per Row
-DP	-037	12 Differential Pairs Per Row
-SE	-025	12 Single-ended Signals Per Row
-SE	-037	18 Single-ended Signals Per Row
-DS	-025	2 Rows of 12 SE, Remaining Rows 8 DP Each
-DS	-037	2 Rows of 18 SE, Remaining Rows 12 DP Each

View complete specifications at: samtec.com?ARP6

APF6	NO. OF POSITIONS	LEAD STYLE	PLATING	ROW	SOLDER TYPE	OPTION	"X"R
	-025, -037 (Per Row)	Leave blank for -RA & -RA-S -03.5 = (3.5 mm) .138"	-L = 10 μ" (0.25 μm) Gold on contact area, Matte Tin on tail (Not available with -RA & -RA-S) -S = 30 μ" (0.76 μm) Gold on contact area, Matte Tin on tail	-04 = Four Rows -06 = Six Rows -08 = Eight Rows	-0 = Column Attach (not available with -RA-S) -1 = Tin/Lead Alloy Solder Charge (-RA & -RA-S only) -2 = Lead-Free Solder Charge (-RA & -RA-S only)	-L = Squeeze Latch -T = Through-hole Locking Tool -S = Surface Mount Locking Tool (-06 & -08 only) -RA = Right-angle panel mount (-04 row only) (Requires cage; visit samtec.com?APF6-C) -RA-S = Right-angle mid-board shield (-04 row & ARP6-S mate only)	-TR = Tape & Reel -FR = Full Reel Tape & Reel (must order maximum quantity per reel; contact Samtec for quantity breaks)

APF6-L, APF6-T, APF6-S, APF6-RA, APF6-RA-S

Cable Mates:
ARP6

(22.39) .881
(13.50) .531
(17.59) .693
(9.90) .390
(12.08) .476

APF6-025-03.5-X-04-0-L SHOWN

Note:
Some sizes, styles and options are non-standard, non-returnable.

View complete specifications at: samtec.com?APF6-L, samtec.com?APF6-T, samtec.com?APF6-S, samtec.com?APF6-RA & samtec.com?APF6-RA-S

ACCELERATE®

SLIM, DIRECT ATTACH CABLE ASSEMBLIES

(0.635 mm) .025" PITCH



PAM 4
64
G b p s

FEATURES & BENEFITS

- Slimmest cable assembly in the industry - 7.6 mm width
- High-density 2-row design; 8, 16 and 24 differential pair configurations
- Differential pair (Thinax™), single-ended (ThinSE™) and mixed signaling available
- Multiple wiring options including reverse polarity
- Mating board level socket (ARF6 Series) features standard rugged weld tabs for increased stability on the PCB
- Rugged metal latching and shielding
- Supports 64 Gbps PAM4 (32 Gbps NRZ) applications; PCIe® 6.0/CXL® 3.2 capable
- Utilizes Samtec's Flyover® Technology to simplify board layout and extend signal reach
- In development: AcceleRate® Boost cable-to-board system provides optimized 112 Gbps PAM4 performance with up to 96 differential pairs using Thinax™ ultra low skew twinax cable. This is the next evolution of Samtec's popular ARC6/ARF6 product solution.



Contacts directly soldered to the twinax for improved signal integrity

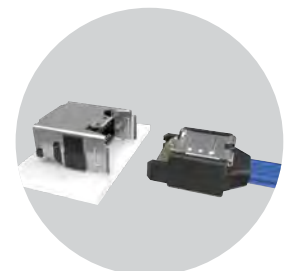

Right-angle available.
Visit [samtec.com?ARF6-RA](https://www.samtec.com?ARF6-RA) for specifications.

KEY SPECIFICATIONS (ARC6/ARF6)

CABLE	INSULATOR MATERIAL	CONTACT MATERIAL	PLATING	OPERATING TEMP RANGE	CURRENT RATING	VOLTAGE RATING
34 AWG, 100 Ω ultra low skew twinax cable	Black LCP	Copper Alloy	Au over 50 μ" (1.27 μm) Ni	-40 °C to +125 °C	1.2 A (1 pin powered)	135 VAC/191 VDC
34 AWG, 92 Ω Thinax™ ultra low skew twinax cable						
34 AWG, 50 Ω ThinSE™ coax cable						

PCI-SIG®, PCI Express® and the PCIe® design marks are registered trademarks and/or service marks of PCI-SIG.

(0.635 mm) .025" • SLIM CABLE & SOCKET

ARC6	SIGNAL TYPE	NO OF PAIRS/POSITIONS	CABLE LENGTH	END 1	END 2	WIRING OPTION	CABLE TYPE
	Leave blank for Differential Pair (-DP) -S = Single-Ended -M = Mixed -DP & -S	-08, -16, -24 (-DP only) -13, -25, -37 (-S & -M only)	-“XX.X” = Length in Inches 03.0” (76.2 mm) minimum	-LU = Latch Up	-LU = Latch Up -LD = Latch Down (Not available with -M style)	-2 = Pin 1 to Pin 2 (End 2 -LD option only) -3 = Pin 1 to Pin N-1 (End 2 -LU option only) -2R = Pin 1 to Pin 2 Reversed Polarity (-DP style & End 2 -LD option only) 06.0” (152.4 mm) min. cable length -3R = Pin 1 to Pin N-1 Reversed Polarity (-DP style & End 2 -LU option only) 06.0” (152.4 mm) min. cable length	-1 = 34 AWG, 100 Ω ultra low skew twinax cable (-DP only) -3 = 34 AWG, 92 Ω Thinax™ ultra low skew twinax cable (-DP only) -4 = 34 AWG, 50 Ω ThinSE™ coax cable (-S only) -6 = Thinax™ (-3) and ThinSE™ (-4) cables (-M only)

ARC6
Board Mates:
ARF6



NO. OF PAIRS/POSITIONS	A	N	N-1
-08/-13	(10.90) .429	26	25
-16/-25	(18.52) .729	50	49
-24/-37	(26.14) 1.029	74	73

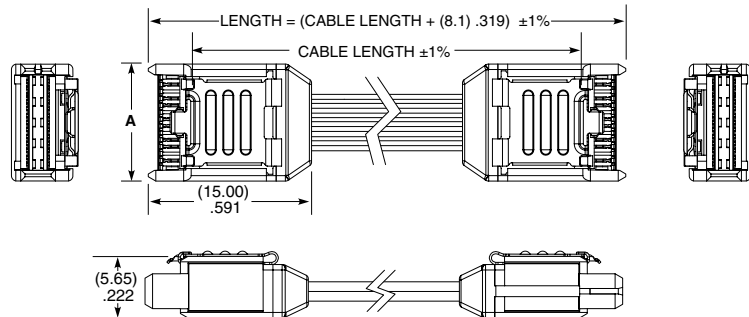

ARC6-08-XX.X-LU-LU-3-X SHOWN

Notes:
Cable lengths longer than 40.00" (1 meter) are not supported with S.I. test data.

View complete specifications at: samtec.com?ARC6

ARF6	NO. OF PAIRS	PLATING	ROW	A	K	"X"R
	-08 (13 pins/row) -16 (25 pins/row) -24 (37 pins/row)	-S = 30 μ" (0.76 μm) Gold on contact area, Matte Tin on tail -STL = 30 μ" (0.76 μm) Gold on contact area, Matte Tin/Lead on tail	-D = Double Row	-A = Alignment Pin	-K = Polyimide film Pick & Place Pad	-TR = Tape & Reel -FR = Full Reel Tape & Reel (must order maximum quantity per reel; contact Samtec for quantity breaks)

ARF6
Cable Mates:
ARC6

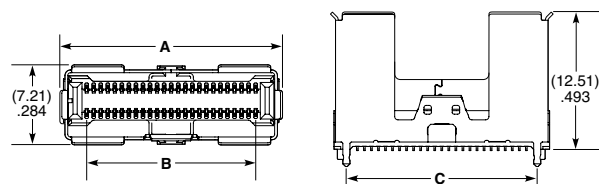
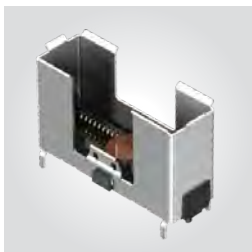

ARF6-16-S-D-A SHOWN

NO. OF PAIRS	A	B	C
-08	(12.46) .491	(7.62) .300	(9.59) .378
-16	(20.08) .791	(15.24) .600	(17.21) .678
-24	(27.70) 1.091	(22.86) .900	(24.83) .978

Notes:
Tape & Reel packaging and K-Dot are standard.

Some sizes, styles and options are non-standard, non-returnable.

View complete specifications at: samtec.com?ARF6

ACCELERATE[®] mini

EXTREME PERFORMANCE, MINI FORM FACTOR CABLE

(0.635 mm) .025" PITCH

NRZ	PAM4
56 Gbps	112 Gbps



VARIOUS END OPTIONS AVAILABLE



800G Flyover[®] QSFP Double Density (FQSFP-D8)

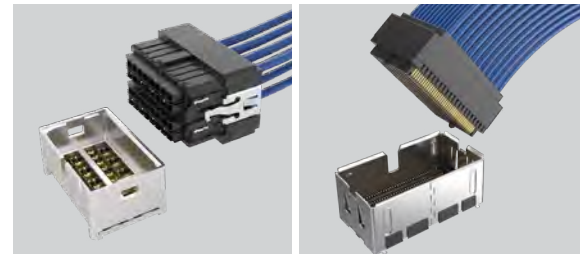

Si-Fly[®] HD
(SFNC/SFNM-L)

AcceleRate[®] HP Double
Density (ART6/ATF6)

FEATURES & BENEFITS

- 112 Gbps PAM4 performance
- 34 AWG, 92 Ω Eye Speed Thinax[™] ultra low skew twinax cable or extruded outer insulation for rugged applications
- One or two differential pairs
- Vertical and right-angle mating board connector
- Design flexibility as an End 2 option for Flyover[®] assemblies
- Friction retention latching
- Standard alignment pins

KEY SPECIFICATIONS

CABLE	INSULATOR MATERIAL	CONTACT MATERIAL	PLATING	OPERATING TEMP RANGE	CURRENT RATING	VOLTAGE RATING
34 AWG, 92 Ω ultra low skew twinax or Thinax [™]	LCP	Copper Alloy	Au or Sn over 50 μ" (1.27 μm) Ni	-40 °C to +105 °C	2.0 A (per pair)	185 VAC/262 VDC

(0.635 mm) .025" • MINI FORM FACTOR CABLE ASSEMBLY

ARM6	NO. OF PAIRS	CABLE LENGTH	END 1	END 2	WIRING OPTION	CABLE STYLE
	-01, -02	- "XX.X" = Length in Inches 03.0" (76.2 mm) minimum	-LUF = Latch up, Flexible Strain Relief	-LUF = Latch up, Flexible Strain Relief -LDF = Latch down, Flexible Strain Relief	-1 = Pin 1 to Pin 1 (End 2 -LDF only) -4 = Pin 1 to Pin N (End 2 -LUF only)	-1 = 34 AWG 92 Ω Thinax™ ultra low skew twinax cable -2 = 34 AWG 92 Ω ultra low skew twinax cable

ARM6
Board Mates:
AMF6

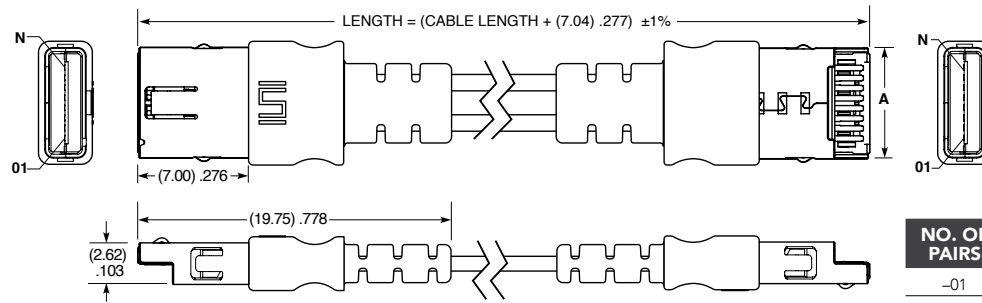

ARM6-02-XX.X-LUF-LDF-4-X SHOWN

Note:
Some sizes, styles and options are non-standard, non-returnable.

View complete specifications at: samtec.com?ARM6

AMF6	NO. OF PAIRS	PLATING	ROW OPTION	OPTION	"X"R
	-01, -02	-S = 30 μ" (0.76 μm) Gold on contact area, Matte Tin on tail	(Leave blank for vertical) -RA = Right-angle	(Leave blank for Right-angle) -K = Polyimide film Pick & Place Pad	-TR = Tape & Reel -FR = Full Reel Tape & Reel (must order maximum quantity per reel; contact Samtec for quantity breaks)

AMF6
Cable Mates:
ARM6

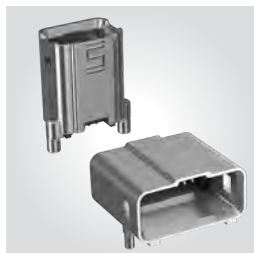

NO. OF PAIRS	A	B	C	C (-RA)
-01	(5.56) .219	(1.91) .075	(5.96) .235	(4.92) .194
-02	(8.10) .319	(4.45) .175	(8.50) .335	(7.46) .294

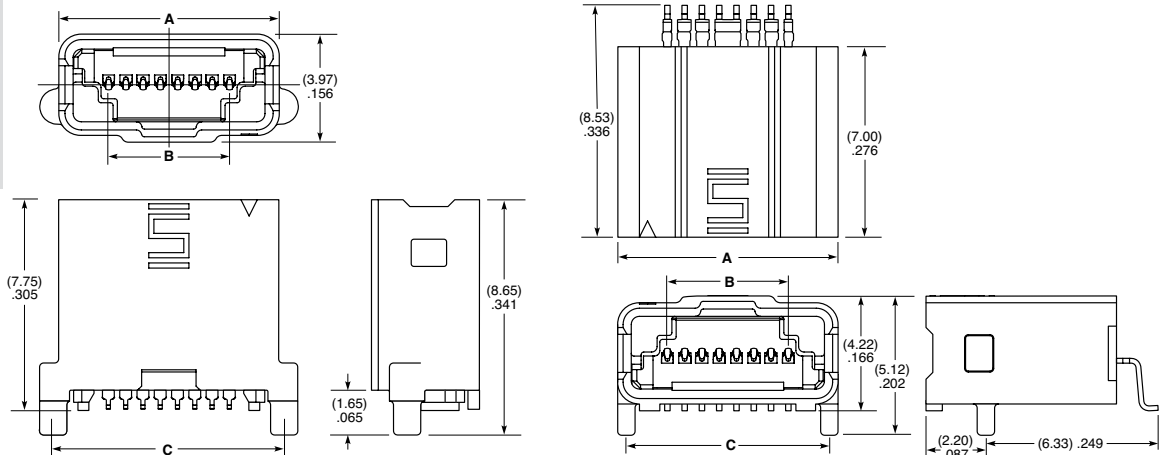

AMF6-02-S-K-XR SHOWN

AMF6-02-S-RA-XR SHOWN

Note:
Some sizes, styles and options are non-standard, non-returnable.

View complete specifications at: samtec.com?AMF6

112 Gbps PAM4, LOW PROFILE HIGH-DENSITY CABLE SYSTEM

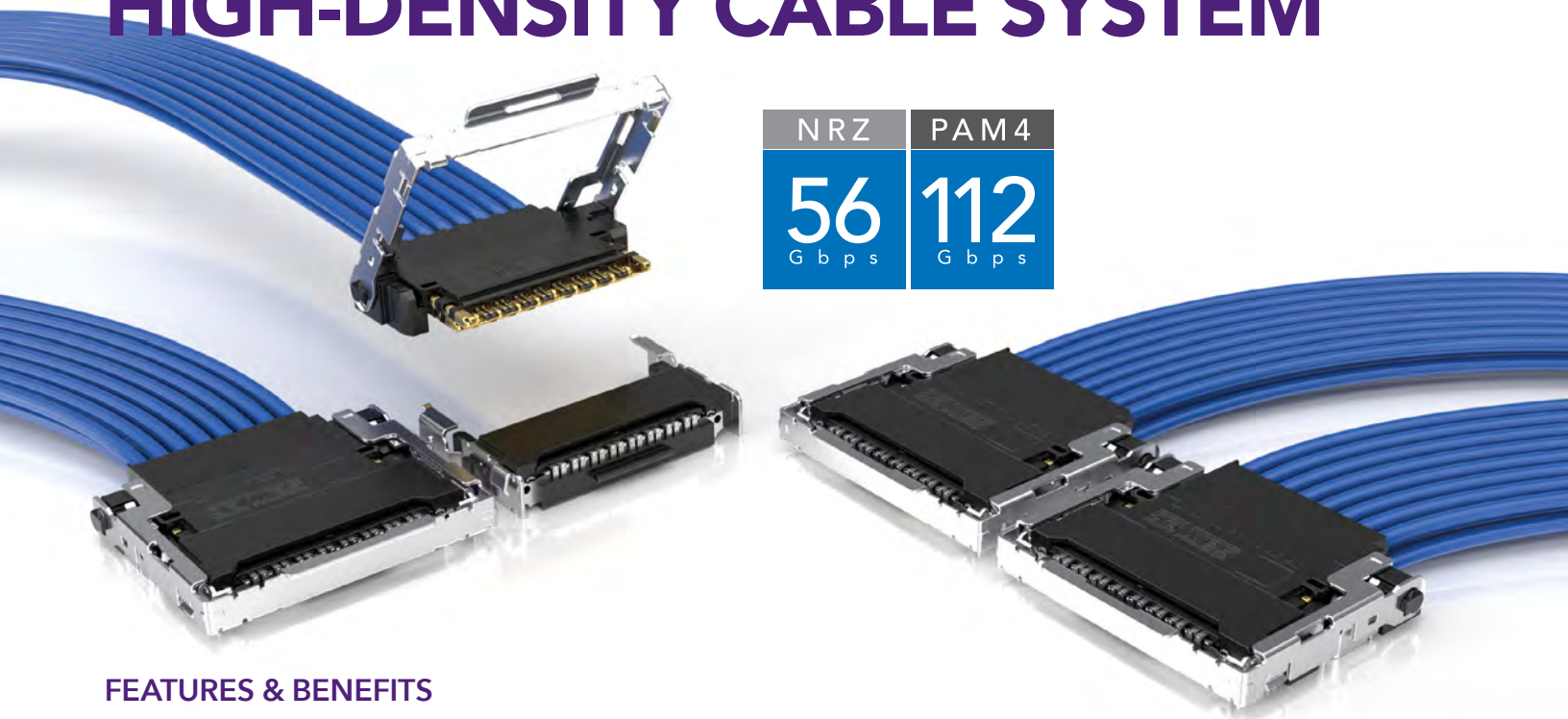

NRZ	PAM4
56	112
Gbps	Gbps

FEATURES & BENEFITS

- Ultra low profile interconnect for placement adjacent to the IC package, under heat sinks or other cooling hardware
- 16 pairs in an incredibly low 4.35 mm profile; 8 pairs in a 3.05 mm profile
- 34 AWG ultra low skew twinax cable; 34 AWG Thinax™ cable in development
- Up to 1.79 Tbps aggregate data rate
- PCIe® 6.0/CXL® 3.2 capable
- Rugged swing latch for positive retention



Multiple connectors can be used side-to-side, front-to-back or in a belly-to-belly configuration



Rugged latching provides a secure connection directly adjacent to the IC package for increased signal integrity performance (16 pair shown)

KEY SPECIFICATIONS (CPC/CPI)

CABLE	SIGNAL ROUTING	INSULATOR MATERIAL	CONTACT MATERIAL	PLATING	OPERATING TEMP RANGE	CURRENT RATING	VOLTAGE RATING
34 AWG ultra low skew twinax	92 Ω & 100 Ω	Black LCP	Copper Alloy	Au over 50 μ" (1.27 μm) Ni	-25 °C to +85 °C	Testing Now!	Testing Now!

PCI-SIG®, PCI Express® and the PCIe® design marks are registered trademarks and/or service marks of PCI-SIG.

0.6 mm LOW PROFILE CABLE & INTERCONNECT

CPC	NO. OF PAIRS	CABLE STYLE	CABLE LENGTH	ROW	END 2	L	WIRING OPTION													
	-08, -16	-1 = 34 AWG, 92 Ω ultra low skew twinax cable -2 = 34 AWG, 100 Ω ultra low skew twinax cable -3 = 34 AWG, 92 Ω Thinax™ ultra low skew twinax cable	-"XX.X" = Wire Length in Inches 06.0" (152.4 mm) minimum	-1 = 1 Row (-08 pairs only) -2 = 2 Row (-16 Pairs only)	-02 = CPC		Specify WIRING OPTION from chart													
					<table border="1"> <thead> <tr> <th>WIRING OPTION</th> <th>ROW</th> <th>CONFIGURATION</th> </tr> </thead> <tbody> <tr> <td rowspan="2">-1</td> <td>Single</td> <td>Pin A1 to A25</td> </tr> <tr> <td>Double</td> <td>Pin A1 to A25 Pin B1 to B25</td> </tr> <tr> <td rowspan="2">-2</td> <td>Single</td> <td>Pin A1 to A1</td> </tr> <tr> <td>Double</td> <td>Pin A1 to B1 Pin B1 to A1</td> </tr> </tbody> </table>		WIRING OPTION	ROW	CONFIGURATION	-1	Single	Pin A1 to A25	Double	Pin A1 to A25 Pin B1 to B25	-2	Single	Pin A1 to A1	Double	Pin A1 to B1 Pin B1 to A1	
WIRING OPTION	ROW	CONFIGURATION																		
-1	Single	Pin A1 to A25																		
	Double	Pin A1 to A25 Pin B1 to B25																		
-2	Single	Pin A1 to A1																		
	Double	Pin A1 to B1 Pin B1 to A1																		

CPC
Board Mates:
CPI

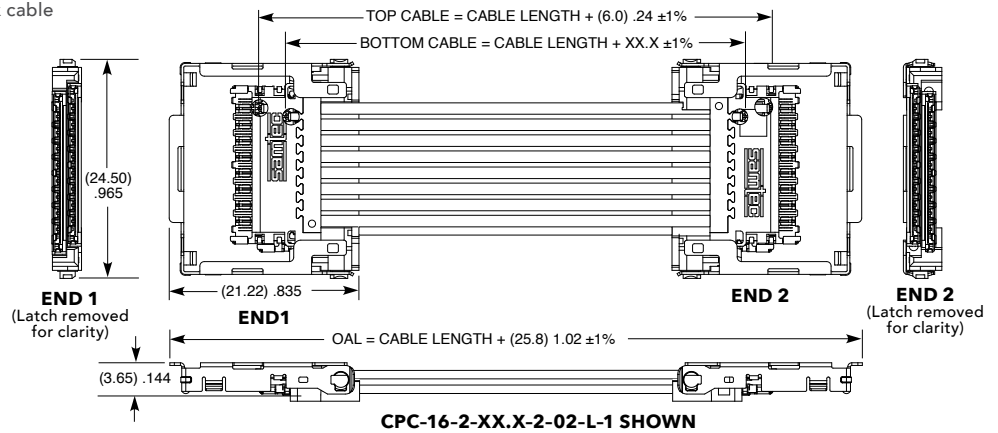

Note:
Cable lengths longer than 40.00" (1 meter) are not supported with S.I. test data.

View complete specifications at: samtec.com?CPC

CPI	NO. OF PAIRS	LEAD STYLE	ROW	PLATING OPTION	RA	0	L	"X"R
	-08, -16	-01 = Surface Mount	-1 = 1 Row, 8 Pairs -2 = 2 Row, 16 Pairs	-S = 30 μ" (0.76 μm) Gold on contact area, Tin on tail				-TR = Tape & Reel -FR = Full Reel Tape & Reel (must order max. quantity per reel; contact Samtec for quantity breaks)

CPI
Cable Mates:
CPC

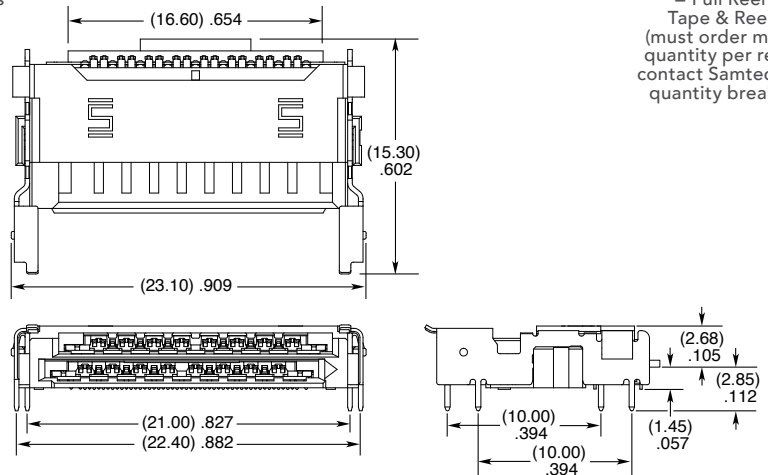
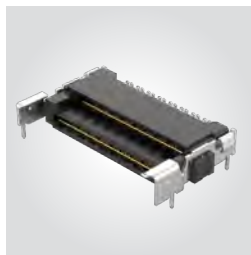

Note:
Some lengths, styles and options are non-standard, non-returnable.

View complete specifications at: samtec.com?CPI

SI-FLY[®] HD

224 GBPS PAM4, CO-PACKAGED AND NEAR-CHIP SYSTEMS



FEATURES & BENEFITS

- High-density 224 Gbps PAM4 co-packaged and near-chip (ASIC adjacent) cable systems
- Co-packaged offers the lowest loss signal transmission from the package to the front panel or backplane while providing the highest density
- PCIe[®] 7.0 capable
- Eye Speed[®] hyper low skew twinax cable technology supports 224G signaling with an industry leading 1.75 ps/m max intra-pair skew
- Placement of Flyover[®] cable solutions on, or near, the chip package improves transmission line density and extends signal reach in high-performance applications
- Co-packaged signal density: 170 differential pairs per square inch
- Near-chip signal density: 64 differential pairs per square inch
- Routes an extremely high number of transmission lines from one PCB to the next
- Surface mount reflow technology to the substrate (co-packaged) or PCB (near-chip)



CPX: Electrically pluggable co-packaged copper and optic high-performance, high-density interconnects on a 95 mm x 95 mm or smaller substrate (SFCC, SFCC, Optics). Contact HDR@samtec.com for more details.

KEY SPECIFICATIONS

SERIES	CABLE	SIGNAL ROUTING	INSULATOR MATERIAL	CONTACT MATERIAL	PLATING	OPERATING TEMP RANGE	CURRENT RATING	VOLTAGE RATING
SFCC/SFCM SFNC/SFNM	32 AWG hyper low skew twinax	92 Ω Differential	Black LCP	Copper Alloy	Au or Sn over 50 μ" (1.27 μm) Ni	Testing Now!	Testing Now!	Testing Now!

CO-PACKAGED CABLE & CONNECTOR

SFCC	STYLE	1	NO. OF PAIRS PER ROW	NO. OF ROWS	RA	CABLE LENGTH	END 2 OPTION	WIRING OPTION
------	-------	---	----------------------	-------------	----	--------------	--------------	---------------

-DP
= Differential
Twinax pairs
only

-08
= Eight

-04
= Four
Rows

-“XX.X”
= Length in Inches
06.0” (152.4 mm)
minimum

-A
= SFCC

-1
= Pin A01 to Pin A25

-08
= Eight
Rows

-2
= Pin A01 to Pin X01

SFCC
Board Mates:
SFCM

PRELIMINARY

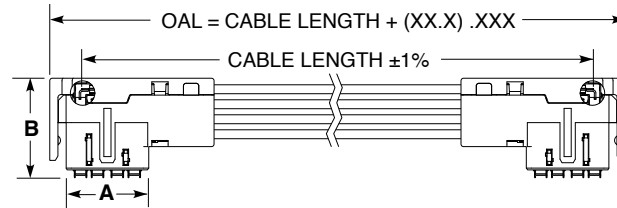

NO. OF ROWS	A	B
-04	(8.10) .319	(9.20) .362
-08	(15.30) .602	(16.26) .640

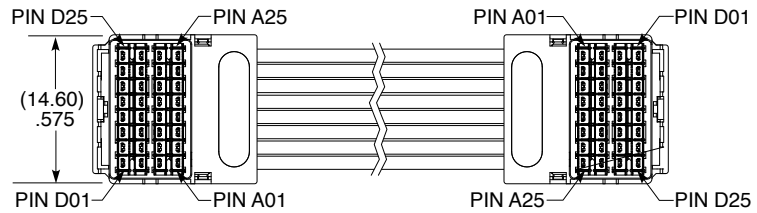

SFCC-DP-1-08-04-RA-XX.X-A-1

Notes:
Cable lengths longer than
118” (3 meter) are not
supported with S.I. test data.

Some lengths, styles and
options are non-standard,
non-returnable.

View complete specifications at: samtec.com?SFCC

SFCM	STYLE	NO. OF PAIRS PER ROW	NO. OF ROWS	01	VT	PLATING OPTION	PACKAGING
------	-------	----------------------	-------------	----	----	----------------	-----------

-DP
= Differential
Twinax pairs only

-08
= Eight

-04
= Four Rows

-S
= 30 μ” (0.76 μm)
Gold in contact area,
Tin on tails

Leave blank for tray
packaging

-TR
= Tape & Reel

PRELIMINARY

SFCM
Cable Mates:
SFCC

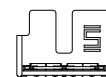
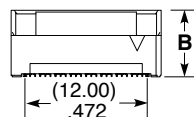
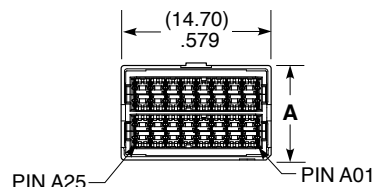

SFCM-DP-08-04-01-VT-S

NO. OF ROWS	A	B	C	D
-04	(9.26) .365	(6.55) .258	(7.05) .278	(10.16) .400
-08	(16.46) .648	(8.55) .337	(9.05) .356	(17.36) .683

-FR
= Full Reel
Tape & Reel
(must order max.
quantity per reel;
contact Samtec for
quantity breaks)

Note:
Some sizes, styles and
options are non-standard,
non-returnable.

View complete specifications at: samtec.com?SFCM

NEAR-CHIP CABLE & CONNECTOR

SFNC	STYLE	1	NO. OF PAIRS PER ROW	NO. OF ROWS	VT	CABLE LENGTH	END 2 OPTION	WIRING OPTION
	-DP = Differential Twinax pairs only		-04 = Four	-04 = Four Rows -08 = Eight Rows		-“XX.X” = Length in Inches 06.0” (152.4 mm) minimum	-A = SFNC-VT End	-1 = Pin A01 to Pin A16 -2 = Pin A01 to Pin N01 (N=Last Row)

PRELIMINARY

SFNC
Board Mates:
SFNM



NO. OF ROWS	A
-04	(11.45) .451
-08	(21.65) .852

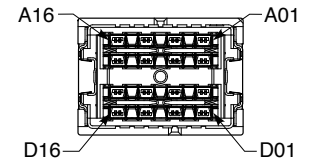
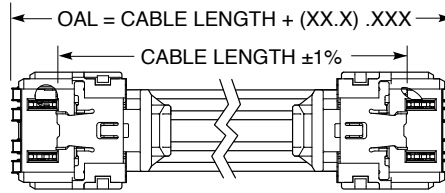
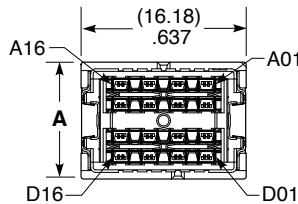

SFNC-DP-1-04-04-VT-XX.X-A-1

Notes:
Cable lengths longer than 118" (3 meter) are not supported with S.I. test data.

Some lengths, styles and options are non-standard, non-returnable.

View complete specifications at: samtec.com?SFNC

SFNM	STYLE	NO. OF PAIRS PER ROW	NO. OF ROWS	01	VT	PLATING OPTION	PACKAGING
	-DP = Differential Twinax pairs only	-04 = Four	-04 = Four Rows -08 = Eight Rows			-S = 30 μ" (0.76 μm) Gold in contact area, Tin on tails	-TY = Tray -TR = Tape & Reel

PRELIMINARY

SFNM
Cable Mates:
SFNC

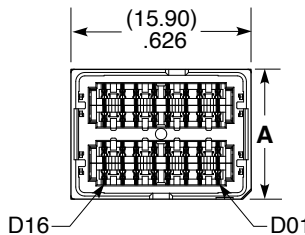

NO. OF ROWS	A
-04	(11.45) .451
-08	(21.65) .852

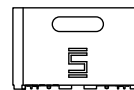
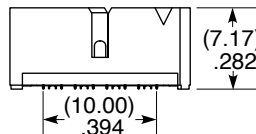

SFNM-DP-04-04-01-VT-S-0-XX

Note:
Some sizes, styles and options are non-standard, non-returnable.

View complete specifications at: samtec.com?SFNM

EDGE CARD CABLE ASSEMBLIES

(0.60 mm) .024" PITCH • GC6 SERIES

PAM4
64
Gbps

GC6

Mates:
HSEC6-DV, HSEC6-RA
(Shield (-S) option
required for mating)

SPECIFICATIONS

Cable:
34 AWG Eye Speed®
ultra low skew twinax

Signal Routing:
100 Ω Differential

Plating:
Au over 50 μ" (1.27 μm) Nickel

Operating Temp Range:
Testing Now!

Current Rating:
Testing Now!

Voltage Rating:
190 VAC/269 VDC

Protocols:
SFF-TA-1002 Compatible

GC6	NO. OF POSITIONS	WIRE LENGTH	END NO. 1	END NO. 2	WIRE MAPPING	CABLE TYPE
	-028 = 28 positions (1C)	-“XX.X” = Wire Length in Inches 06.0” (152.4 mm) minimum	-SU = Straight, Latch Up	-SD = Straight, Latch Down	-1 = Pin A1 to Pin A1	-2 = 34 AWG 100 Ω ultra low skew twinax cable
	-042 = 42 positions (2C)		-RU = Right- angle, Latch Up	-RD = Right- angle, Latch Down (Not available with -SU option)		
	-070 = 70 positions (4C)					

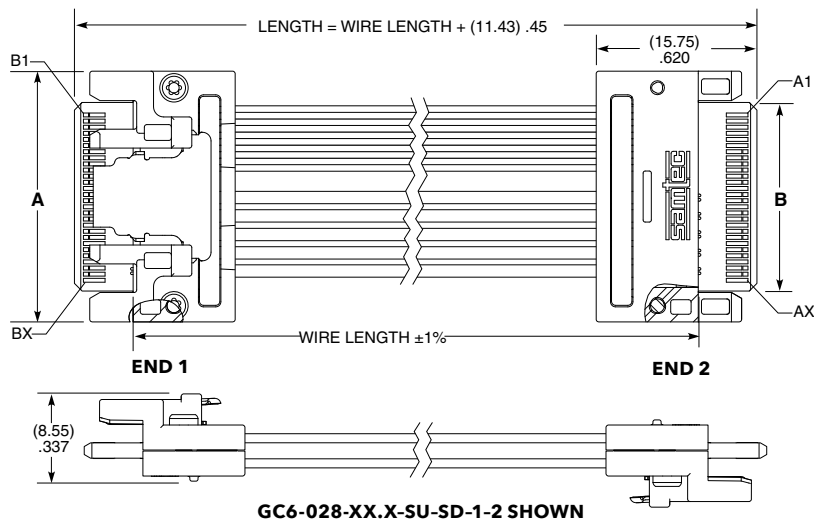

POSITIONS PER ROW	A	B	X
-028	(24.57) .967	(18.480) .728	28
-042	(36.29) 1.429	(30.170) 1.188	42
-070	(57.71) 2.272	(51.280) 2.019	70

Notes:

Cable lengths longer than 40.00" (1 meter) are not supported with S.I. test data.

Design your full cable assembly with Samtec's High-Speed Cable Solutionator® at www.samtec.com/cablebuilder

Some lengths, styles and options are non-standard, non-returnable.

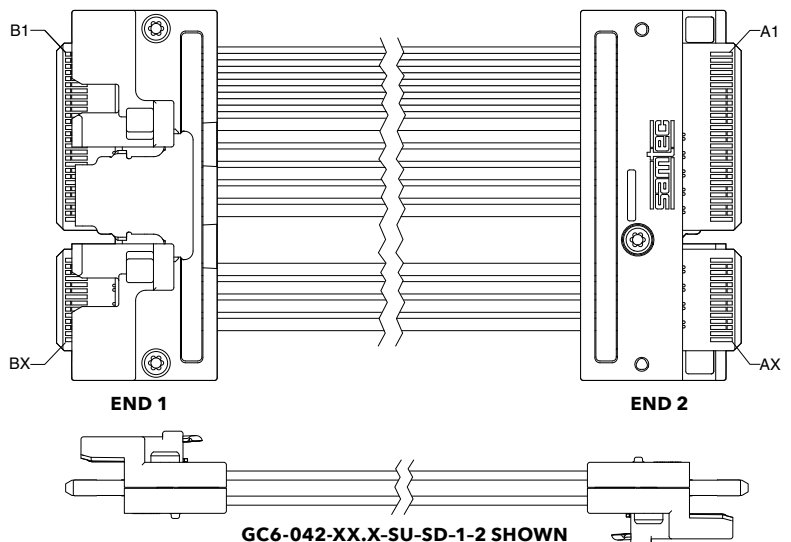

GENERATE

HIGH-SPEED TEST CABLE

GC6RF SERIES

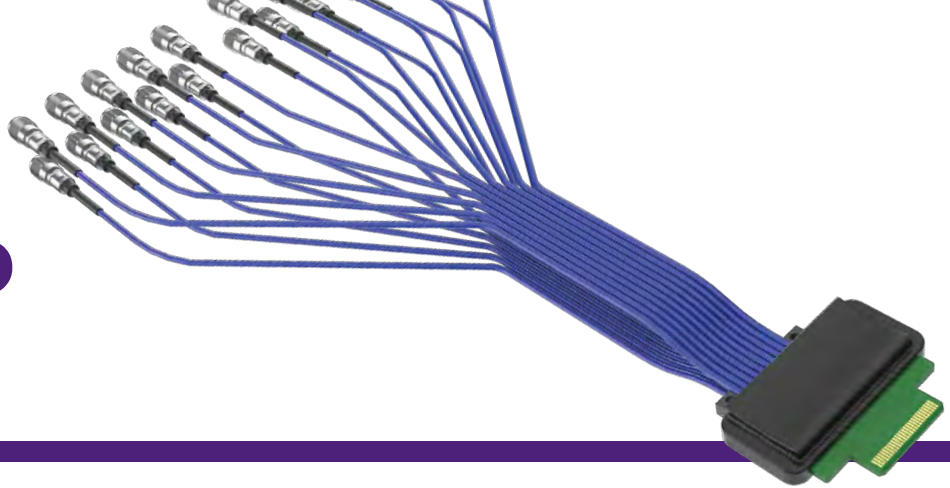

GC6RF

Mates:
HSEC6-DV, HSEC6-RA,
292

SPECIFICATIONS

Card:

Conductor:
1/2 oz. Copper
Contact Area:
Hard Gold
Insulator:
Megtron 6

Cable:

Type:
Low Loss Microwave Coax
Gauge:
31 AWG Silver Plated Copper
Signal Conductor:
(.287) .0113" DIA
Overall Shield Diameter:
(1.17 mm) .046" DIA
Jacket Material:
FEP
Impedance:
50 Ω
Bend Radius:
10.0 Min
Capacitance:
29 pF/foot
Operating Temp:
-65 °C to 150 °C
Frequency Range:
DC to 110 GHz

GC6RF	NO. OF POSITIONS	WIRE LENGTH	END OPTION	RF CONNECTOR	RF GENDER	COAX
	-028 (1C), -042 (2C), -070 (4C) (Per Row)	-"XXXX" = Wire Length in millimeters 1000 mm (39.4") MAX (See Chart for minimum length based on number of positions.)	-EC = Edge Card	-292 = 2.92 mm Connector	-P = Plug -J = Jack	-1 = 31 AWG

PRELIMINARY

NO. OF POSITIONS	A	B	N	NO. OF COAX	MINIMUM WIRE LENGTH
-028	(18.48) .728	(39.18) 1.54	28	20	(0152 mm) 06.0"
-042	(30.17) 1.19	(50.87) 2.00	42	36	(0350 mm) 13.8"
-070	(51.28) 2.02	(71.98) 2.83	70	68	(0500 mm) 19.7"

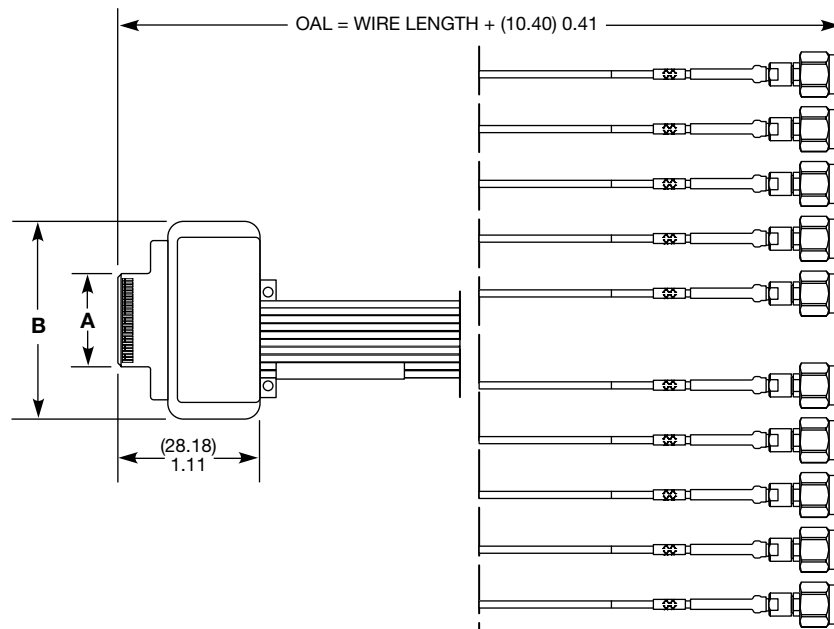

Notes:

Cable lengths longer than 40.00" (1 meter) are not supported with S.I. test data.

Design your full cable assembly with Samtec's High-Speed Cable Solutionator® at www.samtec.com/cablebuilder

This Series is non-standard, non-returnable.

GC6RF-028-XXXX-EC-292-P-1 SHOWN

HIGH-SPEED CABLE ASSEMBLIES

MIX-AND-MATCH FLEXIBILITY • MICRO COAX & TWINAX CABLE • PCI EXPRESS® 2.0/3.0/4.0/5.0

130-131

SEARAY™ HIGH-SPEED,
HIGH-DENSITY CABLE SYSTEM
(SEAC)



SEARAY™

132

PCI EXPRESS® EDGE CARD SYSTEMS
(PCIEC-G4, PCIEC-G5)

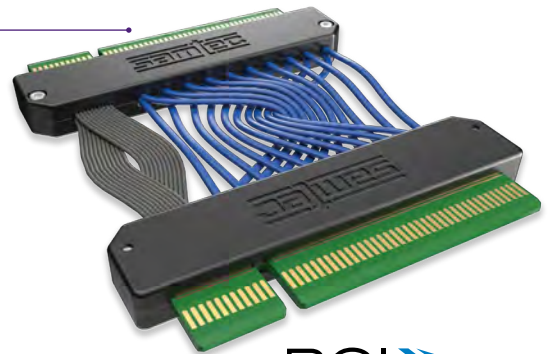

PCI EXPRESS®

133

PCI EXPRESS® HIGH-SPEED TEST
CABLES (PCRF-G4, PCRF-G5)

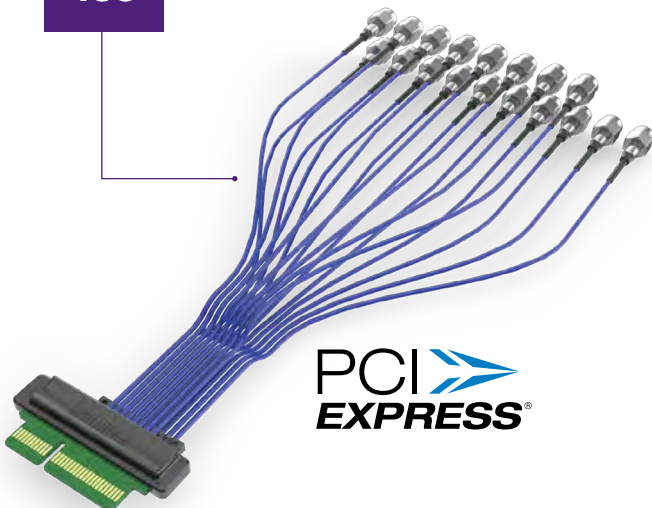

PCI EXPRESS®

134

ADDITIONAL HIGH-SPEED
CABLE SOLUTIONS

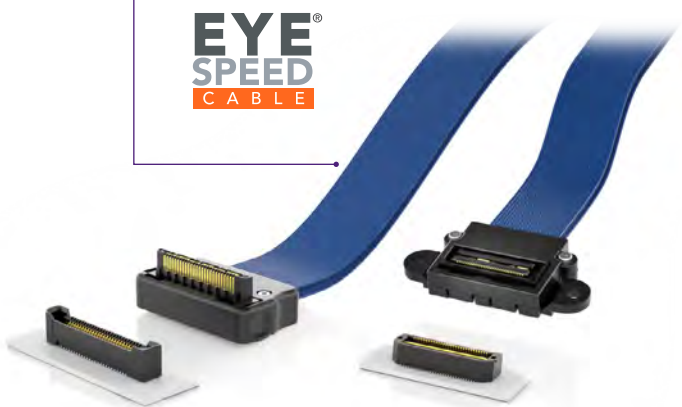

EYE
SPEED
CABLE

HIGH-SPEED CABLE ASSEMBLIES

MICRO COAX & TWINAX ASSEMBLIES • EYE SPEED® CABLE TECHNOLOGY
 DESIGN FLEXIBILITY • EASY CUSTOMS & EXPRESS MODIFICATIONS

MICRO COAX & TWINAX CABLE ASSEMBLIES

- Ability to mix-and match end options for application-specific requirements with extensive customizing capabilities
- Single-ended 50 Ω & differential 100 Ω standards
- Rugged features and options including strain relief, plastic housings, screw downs, latches, locks, etc.
- Many non-cataloged standards available including 75 Ω micro coax and 85 Ω twinax solutions

16
Gbps

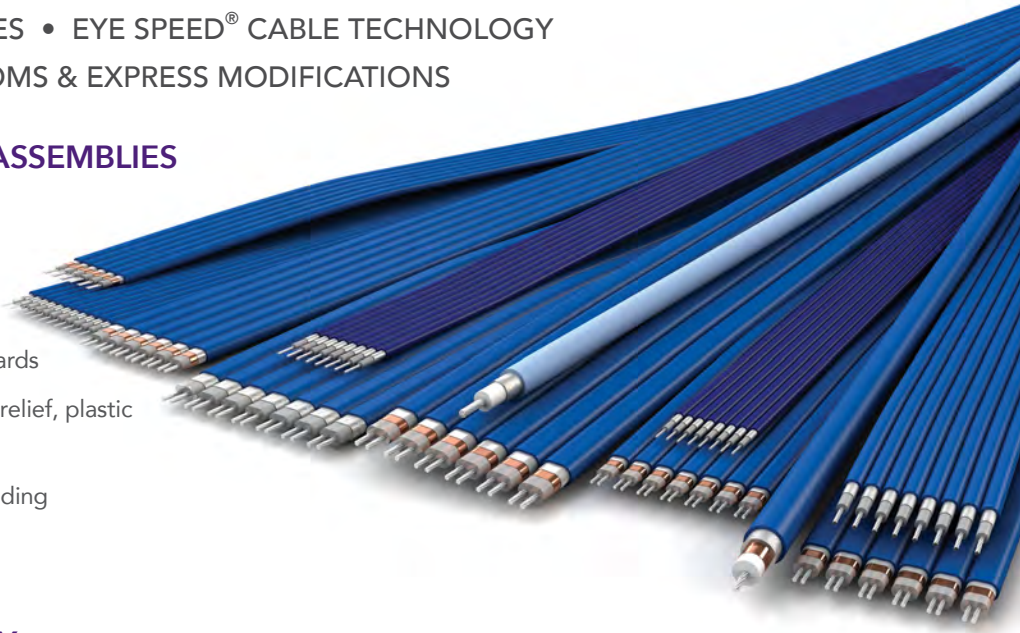

EYE SPEED® CABLE TECHNOLOGY

- Samtec's Eye Speed® cable supports a wide variety of assemblies and applications
- Excellent signal integrity performance with individual copper serve or copper tape shielding

EYE
SPEED
CABLE

- Stranded conductor for small bend radii and dynamic high flexing cycle applications
- Cost-effective ribbonizing eliminates discrete wires
- 26 – 38 AWG coax and twinax construction; 20 Ω, 50 Ω, 85 Ω & 100 Ω

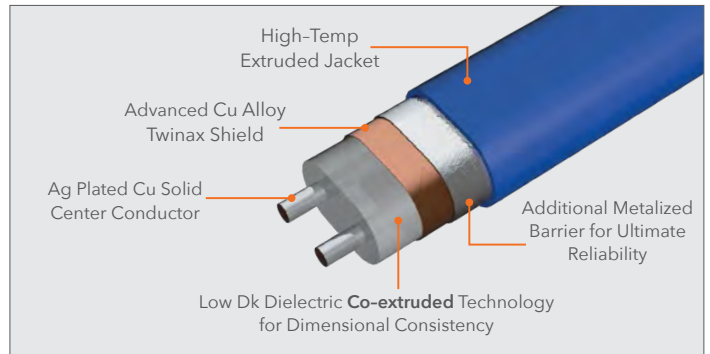
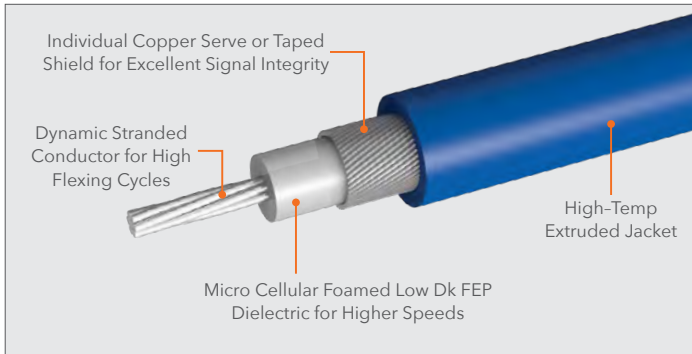

HIGH-SPEED CABLE SOLUTIONATOR®

Quickly design full cable assemblies with this online tool using a wide variety of user-defined search parameters and filters, view models and specifications, request samples and pricing, or place an order. Visit samtec.com/cablebuilder to get started!

Solutionator **HS**
DESIGN IN A MINUTE® CABLE



DESIGN FLEXIBILITY

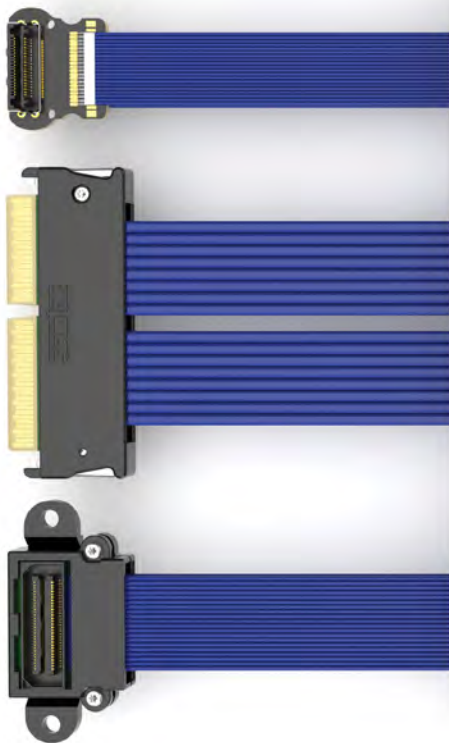

ANY
high-speed **connector**

ANY
pinout **configuration**

ANY
high-speed **precision cable**

... to create a solution for
any specific application.

HDR@samtec.com

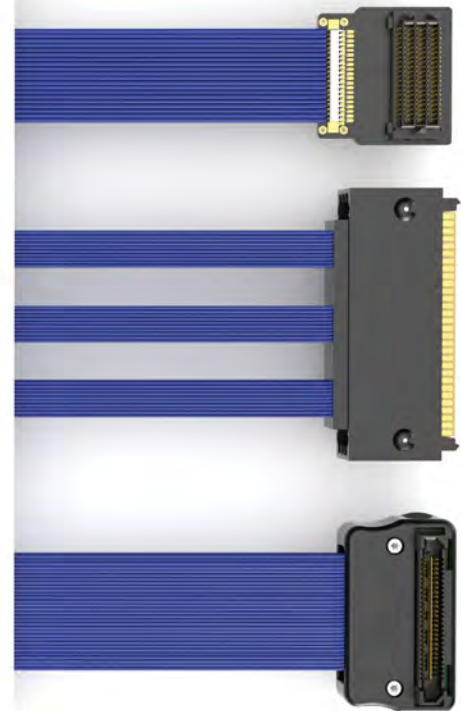

CUSTOMS & EXPRESS MODIFICATIONS

Samtec is able to support new and custom designs, as well as simple modifications to cable assemblies and board-to-board products – often with low or no NRE charges, short lead times, quick-turn samples, and low or no MOQ's. Visit samtec.com/custom for additional details.

- Wiring
- Molding
- Plating
- Polarization
- Contacts
- Bodies
- Stamping
- Ruggedizing features
- Packaging
- Labeling
- Ink printing
- Shielding modifications



WILLINGNESS, SUPPORT & EXPERTISE

- Engineering, design and prototype support
- Design simulation and processing assistance
- Global Operations, including multiple cable fabrication/assembly facilities
- Quotes and samples turned around in 24 hours
- Flexible, quick-turn manufacturing
- Dedicated Application Specific Product engineers and technicians



SEARAY™

HIGH-SPEED, HIGH-DENSITY CABLE ASSEMBLY

(1.27 mm) .050" PITCH



14
G b p s

FEATURES & BENEFITS

- 14 Gbps performance
- Up to 240 I/Os (1/2 of pins are dedicated to ground)
- 4, 6, 8 and 10 row designs
- Choice of Eye Speed® 36 AWG 50 Ω micro coax or 32 AWG 100 Ω twinax cable
- Positive latching when mated to SEAFC with latching post option
- Supports PCIe® 2.0 and 3.0 protocols



Guide post latching available for more rugged applications



Vertical board level mate (SEAFC); samtec.com?seafc



Eye Speed® cable for excellent signal integrity performance

KEY SPECIFICATIONS (SEAC)

CABLE	INSULATOR MATERIAL	CONTACT MATERIAL	PLATING	OPERATING TEMP RANGE	CURRENT RATING	VOLTAGE RATING
36 AWG 50 Ω micro coax or 32 AWG 100 Ω twinax cable	Black LCP	Copper Alloy	Au or Sn over 50 μ" (1.27 μm) Ni	-40 °C to +125 °C (coax) -25 °C to +105 °C (twinax)	0.4 A Specified Cable Rating	120 VAC/170 VDC

(1.27 mm) .050" PITCH • HIGH DENSITY CABLE

SEAC	NO. OF POSITIONS PER ROW	NO. OF ROWS	CABLE LENGTH	TU	TU	CABLE TYPE	LATCH OPTION
	-020 (-04, -06, -08 & -10 row only)	-04, -06, -08, -10	-"XX.X" = Cable Length in Inches (101.6 mm) 04.0" minimum			Leave Blank for 36 AWG 50 Ω coax	Leave Blank for latch post
	-030 (-04, -06 & -08 row only)						-N = No Latch
	-040 (-04 & -06 row only)					-2 = 32 AWG 100 Ω twinax	
	-050 (-04 row only)						

SEAC
Mates:
SEAF8



SIGNAL ROUTING

Product has some lines dedicated to ground. For single-ended and differential pair signal/ground assignments see signal routing information on the assembly print at www.samtec.com?seac Design your High-Speed Cable with Samtec's High-Speed Cable Solutionator® at www.samtec.com/cablebuilder

OTHER SOLUTIONS

Other end options
Mixed SEAC end types
300 positions or greater

Notes:
Mixed latch styles not available

Cable lengths longer than 40.00" (1 meter) are not supported with S.I. test data.

PCIe® 2.0 & 3.0 capable

PCI-SIG®, PCI Express® and the PCIe® design marks are registered trademarks and/or service marks of PCI-SIG.

Some lengths, styles and options are non-standard, non-returnable.

POSITIONS PER ROW	A	B	C
-020	(30.38) 1.196	(33.53) 1.320	(48.26) 1.900
-030	(43.08) 1.696	(46.23) 1.820	(60.96) 2.400
-040	(55.78) 2.196	(58.93) 2.320	(73.66) 2.900
-050	(68.48) 2.696	(71.63) 2.820	(86.36) 3.400

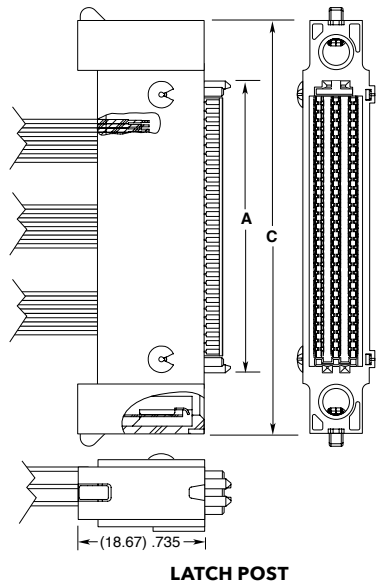
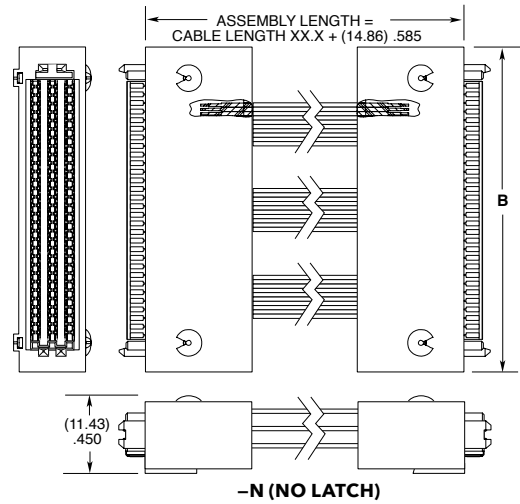

SEARAY™ 0.80 mm CABLE ASSEMBLY

(0.80 mm) .0315" pitch High-Speed Cable in 8 to 10 rows that mates with the SEAM8/SEAF8 Series.

For more information on the ESCA Series, visit samtec.com?ESCA

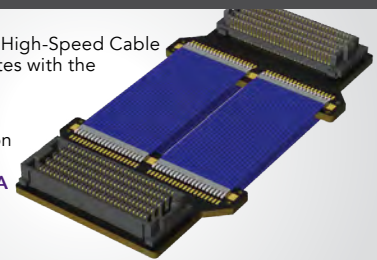

PCI EXPRESS® CABLE ASSEMBLY

(1.00 mm) .0394" PITCH • PCIEC-G4/PCIEC-G5 SERIES

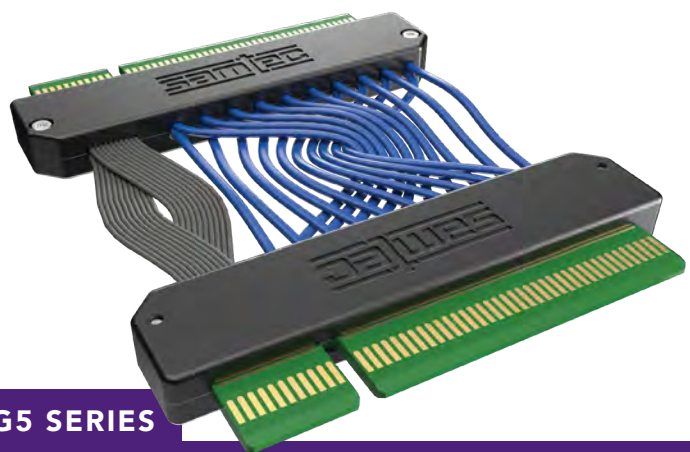

PCIEC-G4

Mates:
PCIE-G4

PCIEC-G5

Mates:
PCIE-G5

SPECIFICATIONS

Cable:
Eye Speed® 34 AWG Twinax;
30 AWG insulated ribbon

Operating Temp:
-25 °C to +105 °C

Contact:
Copper Alloy

Plating:
Au or Sn over 50 μ" Ni

Performance:
Supports PCIe® 4.0/5.0/6.0

Bend Radius:
(3.18 mm) .125"

Current Rating:
PCIEC-G4 = 1 A
PCIEC-G5 = 3.2 A

Voltage Rating:
220 VAC/311VDC

PCIEC	GENERATION	NO. OF POSITIONS	WIRE LENGTH	END NO. 2	CABLE OPTION	IMPEDANCE
-------	------------	------------------	-------------	-----------	--------------	-----------

-G4
= PCIe® 4.0

-036 (x1),
-064 (x4),
-098 (x8),
-164 (x16)

-"XXXX"
= Wire Length
in millimeters
0076 mm
minimum

-C1
= PCIe®
Edge Card
(Tx to Tx
extender)

Leave blank
for no
power

Leave blank
for 100 Ω

-P
= Power

-85
= 85 Ω

-C2
= PCIe®
Edge Card
(Tx to Rx
crossover)

-M1
= PCIEC
Edge Mount
Socket
(Tx to Tx
extender)

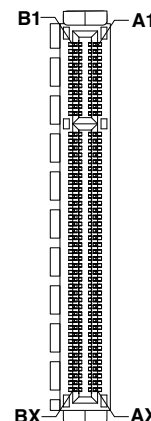
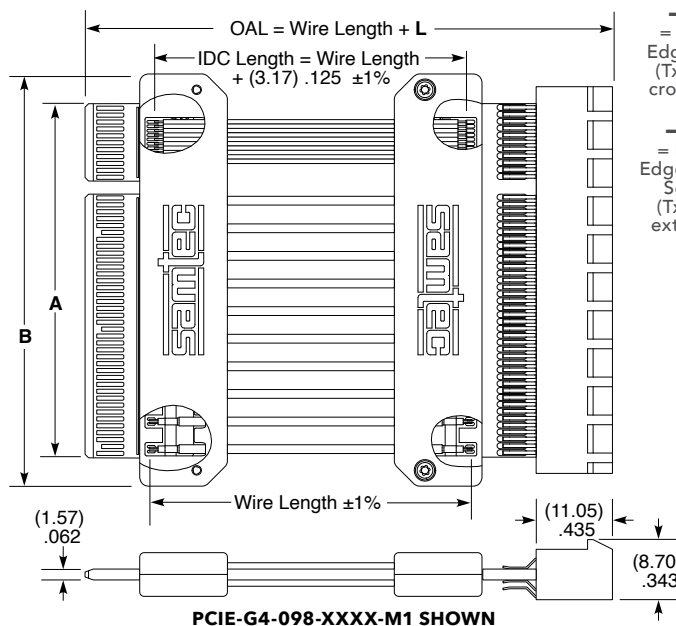

CABLE OPTION	IMPEDANCE	
	85 Ω	100 Ω
BLANK	34 AWG Taped Shield	
-P (With Power Lines)	34 AWG Taped Shield	

* Contact hdr@samtec.com for information

OTHER SOLUTIONS

For speeds of PCIe® 2.0 & 3.0,
visit samtec.com?PCIEC

Notes:
Cable lengths longer than
1015 millimeters are not
supported with S.I. test data.

Design your full cable assembly
with Samtec's High-Speed
Cable Solutionator® at
www.samtec.com/cablebuilder

PCI-SIG®, PCI Express® and
the PCIe® design marks are
registered trademarks and/or
service marks of PCI-SIG.

This Series is non-standard,
non-returnable.

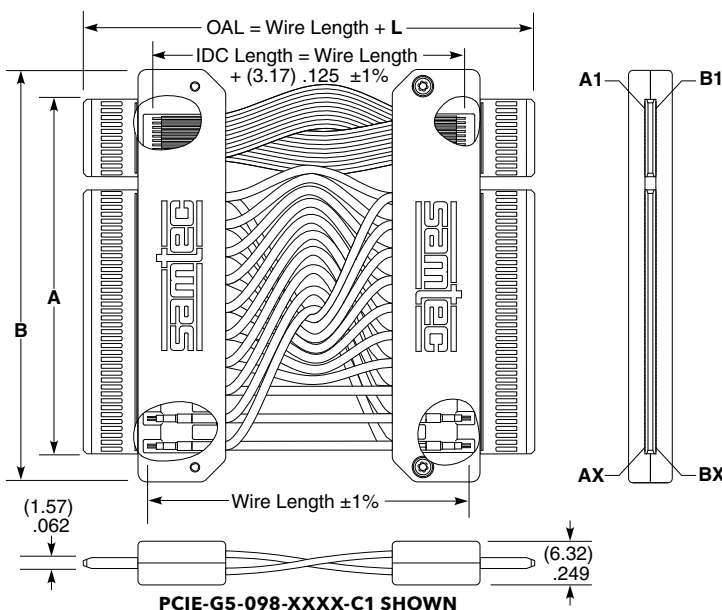

END TO END	L
-C1 to -C1	(18.60) .732
-C1 to -C2	(42.69) 1.68
-C1 to -M1	(29.64) 1.167

NO. OF POSITIONS	X	A	B
-036 (x1)	18	(20.30) .799	(28.69) 1.13
-064 (x4)	32	(34.30) 1.35	(42.69) 1.68
-098 (x8)	49	(51.30) 2.02	(59.69) 2.35
-164 (x16)	82	(84.30) 3.32	(92.69) 3.65

PCI EXPRESS® HIGH-SPEED TEST CABLE

PCRF-G4/PCRF-G5 SERIES

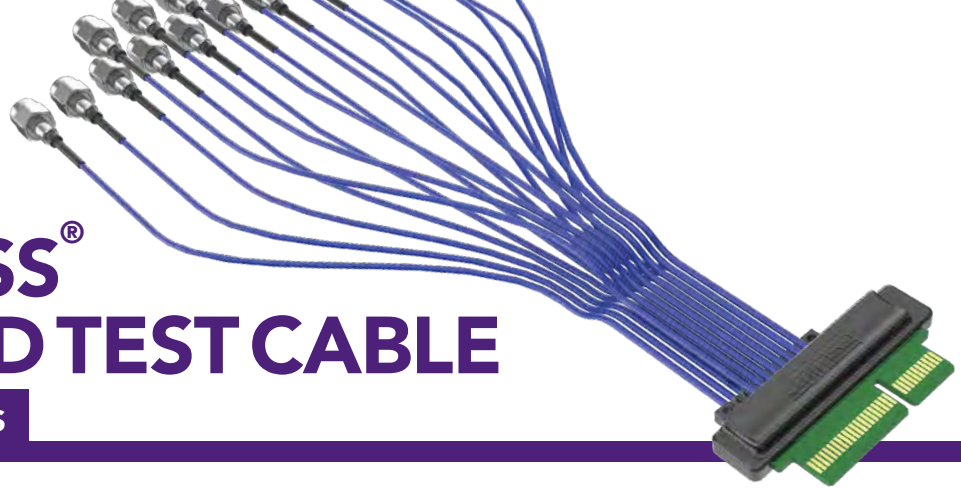

PCRF
Mates:
PCIE-G4, PCIE-G5, 292

SPECIFICATIONS

Card:
Conductor:
1/2 oz. Copper
Contact Area:
Hard Gold
Insulator:
Megtron 6
Cable:
Type:
Low Loss Microwave Coax
Gauge:
29 AWG Silver Plated Copper
Signal Conductor:
(.287) .0113" DIA
Overall Shield Diameter:
(1.17 mm) .046" DIA
Jacket Material:
FEP
Impedance:
50 Ω
Bend Radius:
10.0 Min
Capacitance:
29 pF/foot
Operating Temp:
-65 °C to 150 °C
Frequency Range:
DC to 110 GHz

PCRF	GENERATION	NO. OF POSITIONS	WIRE LENGTH	END OPTION	RF CONNECTOR	RF GENDER	COAX
	-G4 = PCIe® 4.0	-036, -064, -098, -164 (Per Row)	-"XXXX" = Wire Length in millimeters 0152 mm (06.0") MIN 1000 mm (39.4") MAX	-EC = PCIe® Edge Card -EM = PCIe® Edge Mount (-G4 only)	-292 = 2.92 mm Connector	-P = Plug -J = Jack	-1 = 31 AWG

NO. OF POSITIONS	A	B	N	NO. OF COAX
-036	(20.30) .800	(35.54) 1.40	18	6
-064	(34.30) 1.35	(49.54) 1.95	32	18
-098	(51.30) 2.02	(66.54) 2.62	49	34
-164	(84.30) 3.32	(99.54) 3.92	82	66

OTHER SOLUTIONS

PCI Express® cable with SMAs for debug; visit samtec.com?PCRF

Notes:
Cable lengths longer than 40.00" (1 meter) are not supported with S.I. test data.

Design your full cable assembly with Samtec's High-Speed Cable Solutionator® at www.samtec.com/cablebuilder

PCI-SIG® PCI Express® and the PCIe® design marks are registered trademarks and/or service marks of PCI-SIG

This Series is non-standard, non-returnable.

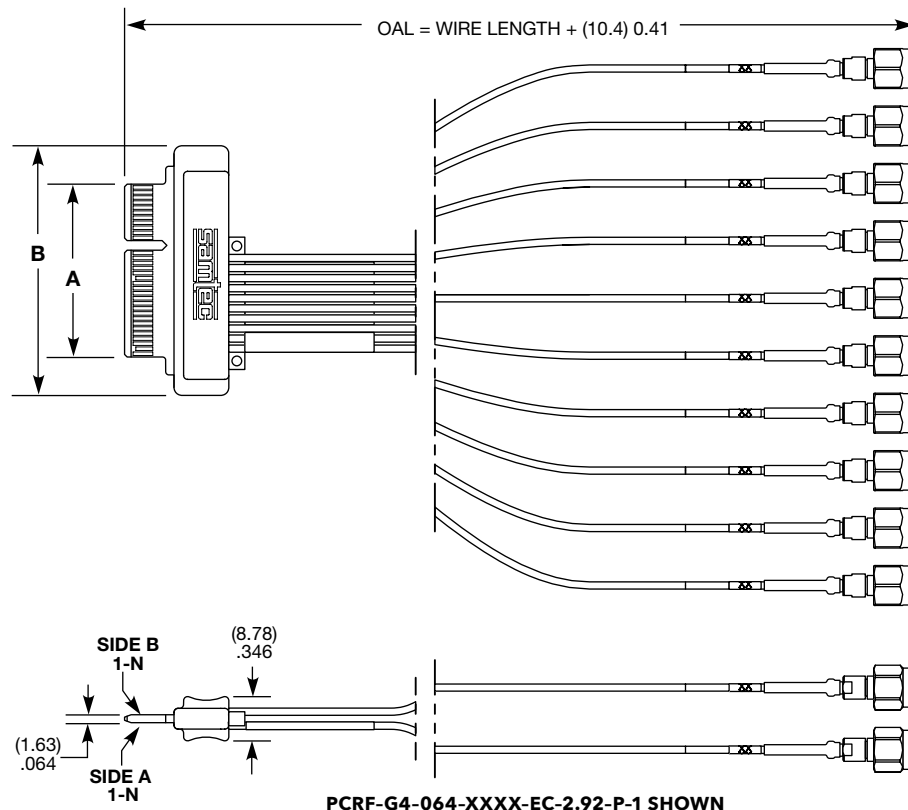

ADDITIONAL HIGH-SPEED CABLE ASSEMBLIES

Ground Plane Assemblies

- Integral power/ground plane
- 34 and 38 AWG coax; 30 and 32 AWG twinax
- 0.50 mm pitch (HQCD/HQDP) and 0.80 mm pitch (EQCD/EQDP) assemblies with rugged screw mount or retention pin options
- 0.80 mm pitch (EQRD) assembly with Edge Rate® contacts for reduced broadside coupling
- Mates with Q Series® and Q Rate® connectors

QSERIES®

QRATE®



View complete specifications at:

samtec.com?HQCD | samtec.com?HQDP | samtec.com?EQCD | samtec.com?EQDP | samtec.com?EQRD

Edge Card Assemblies

- 30 AWG twinax (ECDP); mates with Generate® 0.80 mm pitch edge cards (HSEC8)
- Available without housing for cost savings
- 34 AWG ultra low skew twinax (FEDP); mates with 0.50 mm pitch edge card (FCDP)
- 16 Gbps NRZ performance, to 56 Gbps PAM4 when paired with FQSFP Series or FQSFP-DD Series



View complete specifications at: samtec.com?ECDP | samtec.com?FEDP

High-Speed Assemblies

- Ultra-micro hermaphroditic Razor Beam™ coax assemblies with rugged shielding (HLCD)
- Mates with 0.50 mm pitch Razor Beam™ connectors
- 0.80 mm pitch Edge Rate® coax and twinax assemblies (ERCD, ERDP)
- Low-cost 0.80 mm pitch coax cable system in a compact form factor (FCF8/FCS8)
- 38 AWG coax & 30 AWG twinax assemblies

**EDGE
RATE
SYSTEM**

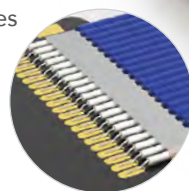

**RAZOR
BEAM
SYSTEM**

View complete specifications at:

samtec.com?HLCD | samtec.com?ERCD | samtec.com?ERDP | samtec.com?FCF8

OPTICS

FUTURE PROOF • HIGH PERFORMANCE • PCI EXPRESS® • END OPTION FLEXIBILITY

136-139

FIREFLY™ MICRO FLYOVER SYSTEM™
(ECUO, ETUO, ETMO)

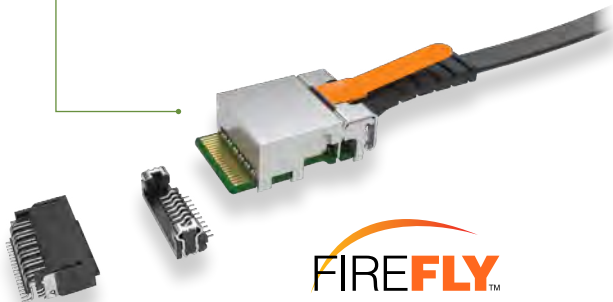

140

PCI EXPRESS®-OVER-FIBER FIREFLY™
SYSTEM (PCUO, PTUO)

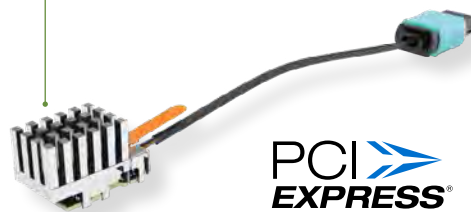

142

PCI EXPRESS®-OVER-FIBER FIREFLY™
ADAPTOR CARD (PCOA)

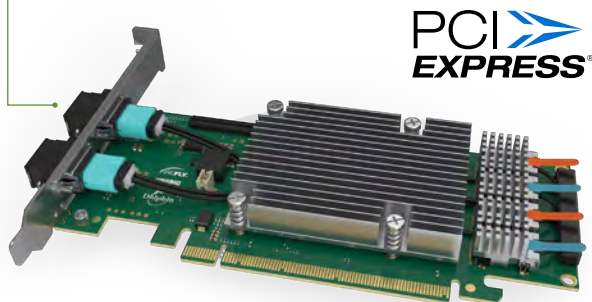

143

OPTICAL PATCH CABLE & ADAPTOR
(FOPC, OPA)

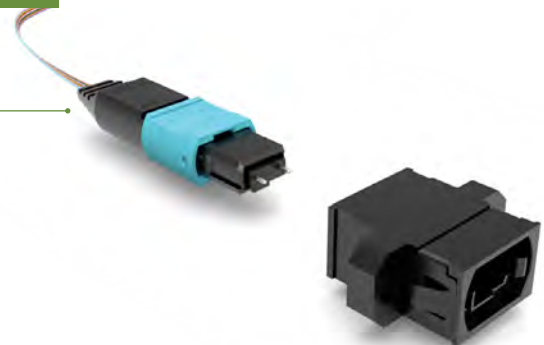

144

HALO® NEXT GEN MID-BOARD OPTICAL
TRANSCEIVERS (HALO-C, HALO-PE, HLF6)

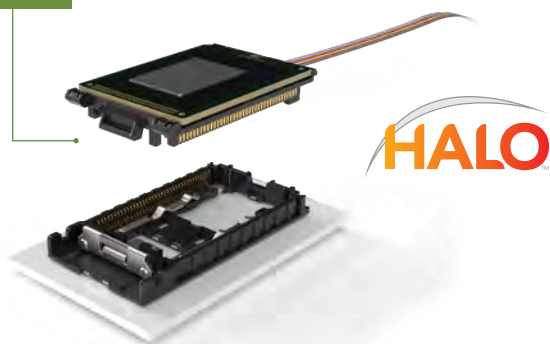

145

FIREHAWK® RUGGEDIZED MID-BOARD
OPTICAL TRANSCEIVERS (CSSO)

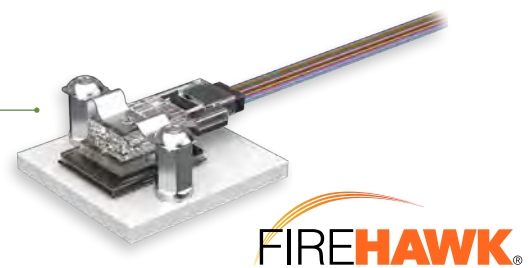

FIREFLY™ MICRO FLYOVER SYSTEM™



FEATURES & BENEFITS

- Data connection taken “off board” simplifies board layout
- Industry leading miniature footprint allows for higher density close to data source
- Performance up to 28 Gbps per lane with a path to 112 Gbps PAM4 via optical cable for greater reach
- Simple assembly process with easy insertion/removal and trace routing, no through-holes
- Interchangeability of copper and optical cable using the same two-piece surface mount connector
- PCIe®-Over-Fiber (PCUO/PTUO) supports PCIe® protocol for low latency, power savings and guaranteed transmission; 3.0 and 4.0 solutions
- -40 °C to +85 °C extended temperature system (ETUO) for industrial applications
- Extreme Environment FireFly™ sealed and parylene-coated for rugged military and aerospace applications (ETMO)
- Multiple end options available: MTP®, MXC®, MT, VITA™ 66.1/66.4 and other common interfaces
- Variety of integral heat sinks for conduction and convection cooling



Micro two-piece connector system

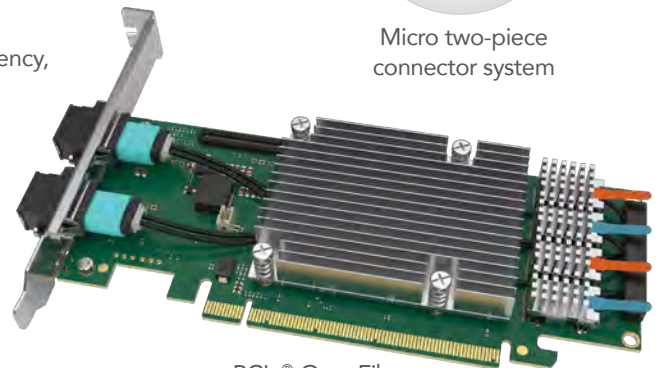

PCIe®-Over-Fiber Adaptor Card

MTP® and MXC® are registered trademarks of US Conec Ltd.
PCI-SIG®, PCI Express® and PCIe® design marks are registered trademarks and/or service marks of PCI-SIG.
VITA™/VNX/VNX+/FMC/FMC+/XMC/XMC+ are all respective trademarks of VITA

FIREFLY™ COPPER

- Performance to 56 Gbps
- 8 or 12 differential pairs
- 100 Ω, 34 or 36 AWG Eye Speed® twinax cable
- Variety of end 2 termination options
- Low profile housing for space savings
- Low-cost solution for seamless integration of new and existing designs

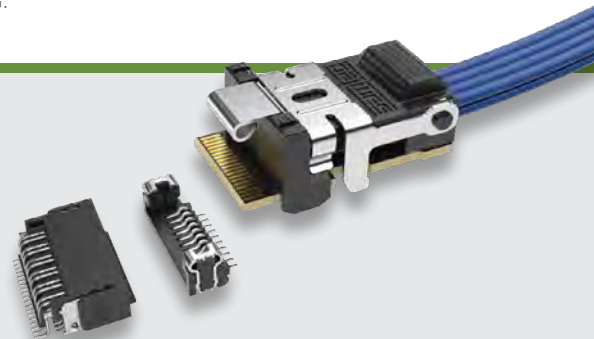

For complete copper FireFly™ or PCIe® over FireFly™ series specifications www.samtec.com?ECUE and www.samtec.com?PCUE

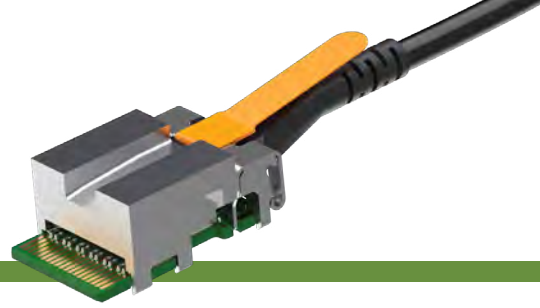

OPTICAL MICRO FLYOVER SYSTEM™

ECUO	WIDTH	DATA RATE	CABLE LENGTH	0	HEAT SINK	1	FIBER TYPE	END 2 OPTIONS
	-B04 = 4 Tx + 4 Rx -T12 = 12 Tx -R12 = 12 Rx -Y12 = 12 Tx + 12 Rx -U12 = 12 Channel AOC (Unidirectional)	-14 = 14 Gbps per lane -16 = 16.1 Gbps per lane (N/A -B04) -25 = 25.7 Gbps per lane (-B04 only) -28 = 28.1 Gbps per lane	-"XXX" = Overall Length in Centimeters		-1 = Flat -2 = Pin-fin (-14 & -16 only) -3 = Flat with groove -4 = PCIe® Pin-fin (-14 & -16 only) -5 = 1.75 cm tall Pin-fin		-5 = Jacketed ribbon with boot -6 = Jacketed ribbon -7 = Black loose tube with boot -8 = Black loose tube	(Leave blank for -U12 or -B04 width) -Y12 requires -2X end option 12 Fibers -01 = MTP® Male -02 = MTP® Female -07 = MXC® Internal Plug* -0E = MPO Plus®, Male, bayonet 24 Fibers -21 = MTP® Male -22 = MTP® Female -27 = MXC® Internal Plug* -2E = MPO Plus®, Male, bayonet

ECUO
Mates with:
UEC5, UCC8,
OPA

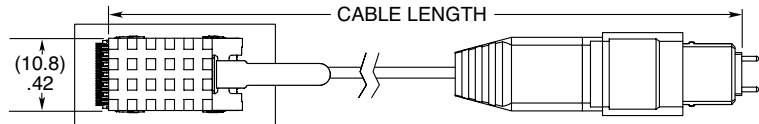

FEATURES

- Supports data center and HPC protocols, including: Ethernet, InfiniBand™, Fibre Channel
- Customizable optical connectors
- Integrated coupling capacitors
- Standard temperature range 0 °C to +70 °C
- Evaluation & Development boards available

TOOLING

Insertion Tool: CAT-IN-ECUO-02

Notes:
MTP® and MXC® are registered trademarks of US Conec Ltd.

PCI-SIG®, PCI Express® and PCIe® design marks are registered trademarks and/or service marks of PCI-SIG.

All FireFly™ designs, specifications and components are preliminary and subject to change without notice.

Some lengths, styles and options are non-standard, non-returnable.

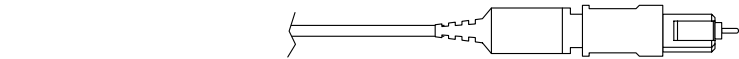

-01 (MTP® MALE SHOWN)

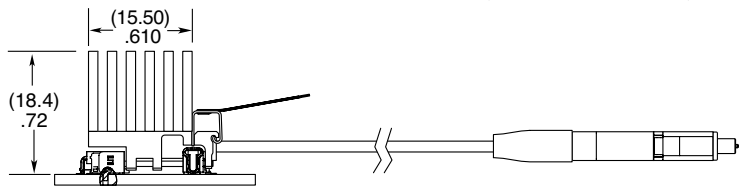

-07 (MXC® INTERNAL PLUG SHOWN)

-2 PIN-FIN HEAT SINK

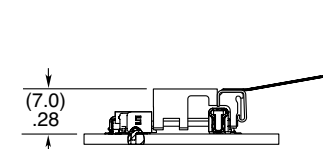

-1 FLAT HEAT SINK

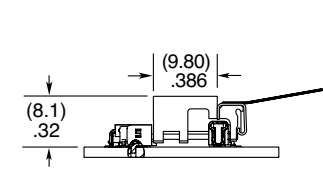

-3 FLAT WITH GROOVE HEAT SINK (MULTI-ROW CONFIGURATION)



CLASS 1 LASER PRODUCT
per IEC 60825-1 Ed. 3 (2014)

Applies to all end 2 options except MXC®

***CLASS 3R LASER PRODUCT**
Laser Radiation. Avoid Direct Eye Exposure.



Applies to MXC® end option only.

View complete specifications at: samtec.com?ECUO

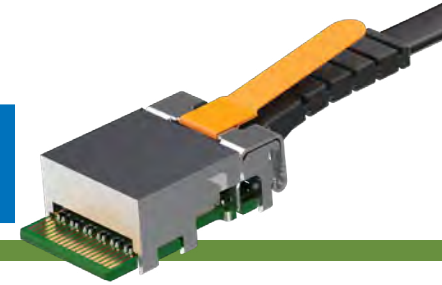

EXTENDED TEMP OPTICAL MICRO FLYOVER SYSTEM™

ETUO	WIDTH	DATA RATE	CABLE LENGTH	0	HEAT SINK	1	FIBER TYPE	END 2 OPTIONS
	-B04 = 4 Tx + 4 Rx -T12 = 12 Tx -R12 = 12 Rx -Y12 = 12 Tx + 12 Rx -U12 = 12 Channel AOC (Unidirectional)	-10 = 10.3125 Gbps -25 = 25.7 Gbps (-B04 only)	-“XXX” = Overall Length in Centimeters		-1 = Flat -2 = Pin-fin -3 = Flat with groove -4 = PCIe® Pin-fin (-10 only) -5 = 1.75 cm tall Pin-fin (-B04 only)		-5 = Jacketed ribbon with boot -6 = Jacketed ribbon -7 = Black loose tube with boot -8 = Black loose tube	(Leave blank for -U12 or -B04 width) -Y12 requires -2X end option 12 Fibers -01 = MTP® Male -02 = MTP® Female -07 = MXC® Internal Plug* -0A = VITA™ 66.1/66.4 READY -0C = MT38999 Male -0E = MPO Plus®, Male, bayonet 24 Fibers -21 = MTP® Male -22 = MTP® Female -27 = MXC® Internal Plug* -2A = VITA™ 66.1/66.4 READY -2C = MT38999 Male -2E = MPO Plus®, Male, bayonet

ETUO
Mates with:
UEC5, UCC8,
OPA

FEATURES

- Optimized for SWaP
- Extended temperature range from -40 °C to +85 °C
- Micro rugged board level connector system with positive latching, weld tabs and loading guides for secure connection
- Pigtailed cable for maximum link budget
- Customizable optical connectors
- Integrated coupling capacitors
- Integral heat sink provides optimal cooling for thermal operating conditions
- Evaluation and Development boards available

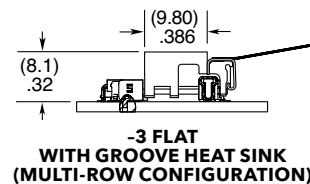
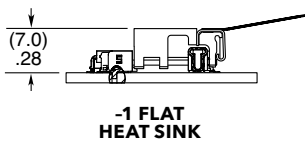
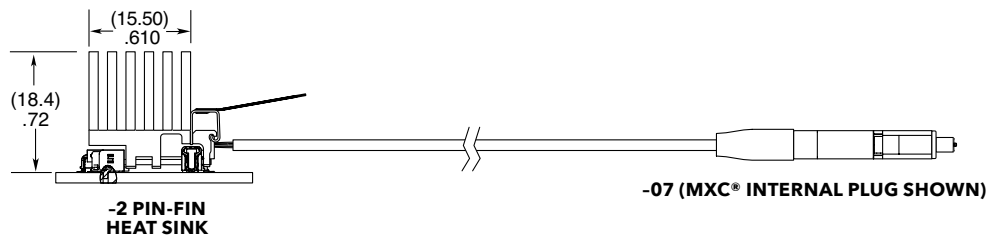

Notes:
All FireFly™ designs, specifications and components are preliminary and subject to change without notice.

MTP® and MXC® are registered trademarks of US Conec Ltd.

PCI-SIG®, PCI Express® and the PCIe® design marks are registered trademarks and/or service marks of PCI-SIG.

VITA/VNX/VNX+/FMC/FMC+/XMC/XMC+ are all respective trademarks of VITA

Some lengths, styles and options are non-standard, non-returnable.

CLASS 1 LASER PRODUCT
per IEC 60825-1 Ed. 3 (2014)

Applies to all end 2 options except MXC®

***CLASS 3R LASER PRODUCT**
Laser Radiation. Avoid Direct Eye Exposure.

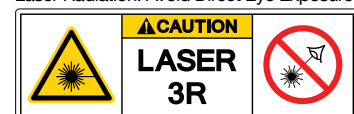

Applies to MXC® end option only.

View complete specifications at: samtec.com?ETUO



EXTREME ENVIRONMENT OPTICAL MICRO FLYOVER SYSTEM™

ETMO	B04	DATA RATE	CABLE LENGTH	2	HEAT SINK	FIRMWARE	FIBER TYPE	END 2 OPTIONS
		-10 = 10.3125 Gbps -25 = 25.7 Gbps	-“XXX” = Overall Length in Centimeters		-1 = Flat -2 = Pin-fin -3 = Flat with groove -4 = PCIe® Pin-fin (-10 Data Rate only)	-1 = Standard -2 = Standard Secure Firmware -3 = Dual Power -4 = Dual Power Secure Firmware	-7 = Black loose tube with boot -8 = Black loose tube	(Leave blank for AOC) -01 = MTP® Male -02 = MTP® Female -07* = MXC® Internal Plug -0A = VITA™ 66.1/66.4 READY -0C = MT38999 Male

PRELIMINARY

ETMO
Mates with:
UEC5, UCC8, OPA

FEATURES

- Dual power mode for interoperability with legacy optical modules
- Secure firmware prevents writes to the non-volatile memory (NVM)
- Extended temp range of -40 °C to +85 °C
- Micro rugged board level connector system with positive latching, weld tabs and loading guides for a secure connection
- Customizable optical end connectors including MT Elite®, MTP Elite®, and low loss MXC®
- Integral heat sink provides optimal cooling for thermal operating conditions
- Sealed and parylene-coated for exposed military, aerospace and submersible applications
- Ruggedized for tin whisker mitigation and fungal resistance; operates in harsh environments including salt fog, blowing sand and dust, jet fuel exposure, altitudes up to 65,000 feet

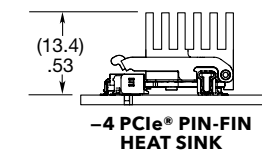
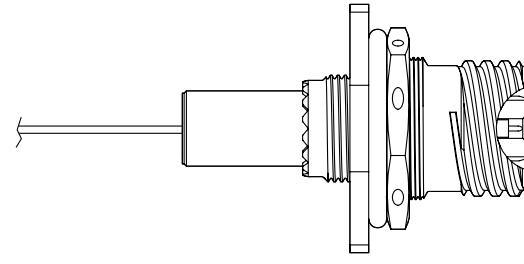
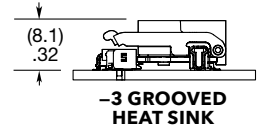
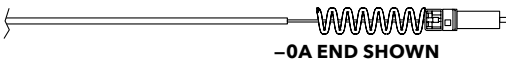
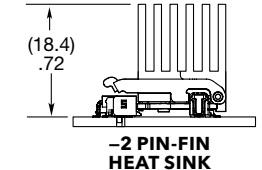
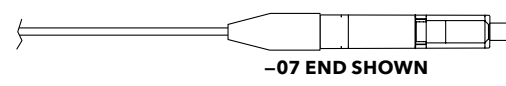
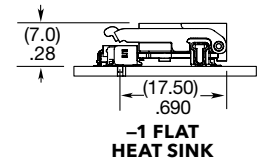
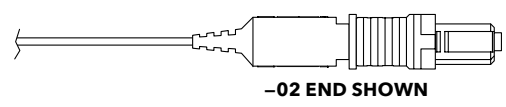
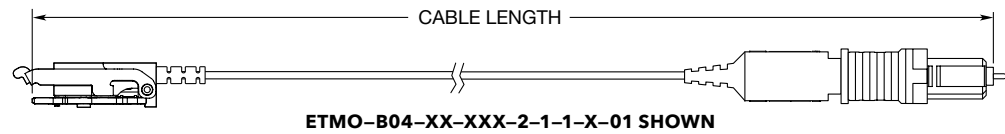

Notes:
All FireFly™ designs, specifications and components are preliminary and subject to change without notice.

MT Elite®, MTP Elite®, and MXC® are registered trademarks of US Connec Ltd.

PCI-SIG®, PCI Express® and the PCIe® design marks are registered trademarks and/or service marks of PCI-SIG.

VITA/VNX/VNX+/FMC/FMC+/XMC/XMC+ are all respective trademarks of VITA

Some lengths, styles and options are non-standard, non-returnable.

CLASS 1 LASER PRODUCT
per IEC 60825-1 Ed. 3 (2014)

Applies to all end 2 options except MXC®

***CLASS 3R LASER PRODUCT**
Laser Radiation. Avoid Direct Eye Exposure.



Applies to MXC® end option only.

View complete specifications at: samtec.com?ETMO

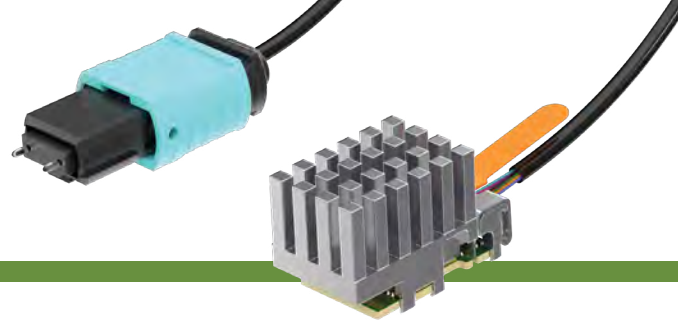

PCIe®-OVER-FIBER FLYOVER®

PCUO	WIDTH	DATA RATE	CABLE LENGTH	0	HEAT SINK	1	FIBER TYPE	END 2 OPTIONS
------	-------	-----------	--------------	---	-----------	---	------------	---------------

PCUO
Mates with:
UEC5, UCC8,
OPA

-04
= x4 Lanes
-08
= x8 Lanes

-G4
= 4.0 Speed

-"XXX"
= Overall Length in Centimeters

-1
= Flat
-4
= PCIe® Pin-fin

-7
= Black loose tube with boot
-8
= Black loose tube

(-04 width requires -01 option; -08 width requires -21 option)
-01/-21
= MTP® Male

FEATURES

- PCIe® 4.0 x4, scalable to x8 and x16 widths
- Duplex auxiliary signals allow both transparent and non-transparent bridging
- High-performance signal quality with BER better than 1E⁻¹²
- Enables links up to 100 m
- Allows nontraditional FPGA/ASIC end points
- Standard temperature range 0 °C to +70 °C

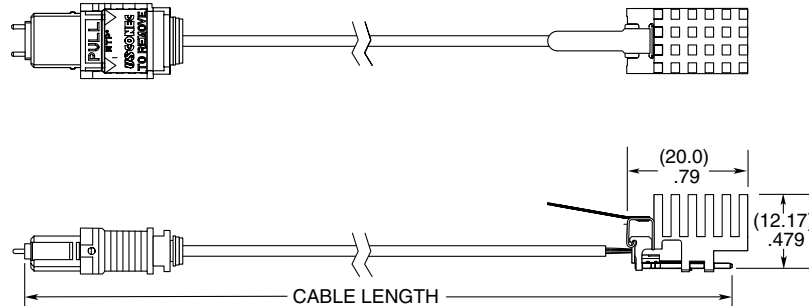

PCUO-04-G4-XXX-0-4-1-8-01 SHOWN

CLASS 1 LASER PRODUCT
per IEC 60825-1 Ed. 3 (2014)

View complete specifications at: samtec.com?PCUO

OTHER SOLUTIONS

PCUO with G3 speeds available. For more information, visit samtec.com?PCUO

EXTENDED TEMP PCIe®-OVER-FIBER

PTUO	WIDTH	DATA RATE	CABLE LENGTH	0	HEAT SINK	1	FIBER TYPE	END 2 OPTIONS
------	-------	-----------	--------------	---	-----------	---	------------	---------------

PTUO
Mates with:
UEC5, UCC8,
OPA

-04
= x4 Lanes
-08
= x8 Lanes

-G3
= 3.0 Speed

-"XXX"
= Overall Length in Centimeters

-1
= Flat
-2
= Pin-fin
-3
= Flat with groove
-4
= PCIe® Pin-fin

-7
= Black loose tube with boot
-8
= Black loose tube

(-04 width requires -0X option; -08 width requires -2X option)

-01/-21
= MTP® Male

-02/-22
= MTP® Female

-0A/-2A
= VITA™ 66.1/66.4 Ready

-0C/-2C
= MT38999 Male

FEATURES

- Extended temperature range from -40 °C to +85 °C
- PCIe® 3.0 x4, scalable to x8 and x16 widths
- Duplex auxiliary signals allow both transparent and non-transparent bridging
- High-performance signal quality with BER better than 1E⁻¹²
- Enables links up to 100 m
- Allows nontraditional FPGA/ASIC end points
- Additional heat sink and end options available
- PCIe® 4.0 version in development

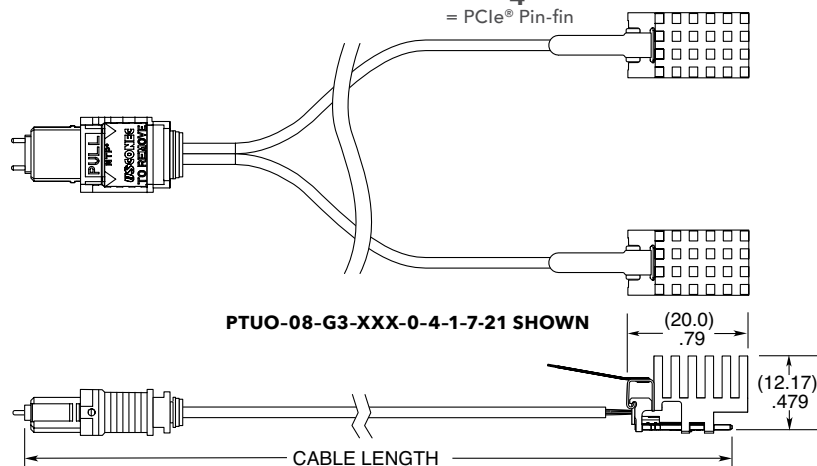

PTUO-08-G3-XXX-0-4-1-7-21 SHOWN

CLASS 1 LASER PRODUCT
per IEC 60825-1 Ed. 3 (2014)

View complete specifications at: samtec.com?PTUO

Notes:
MTP® is a registered trademark of US Conec Ltd.

PCI-SIG®, PCI Express® and the PCIe® design marks are registered trademarks and/or service marks of PCI-SIG.

VITA/VNX/VNX+/FMC/FMC+/XMC/XMC+ are all respective trademarks of VITA

Some lengths, styles and options are non-standard, non-returnable.

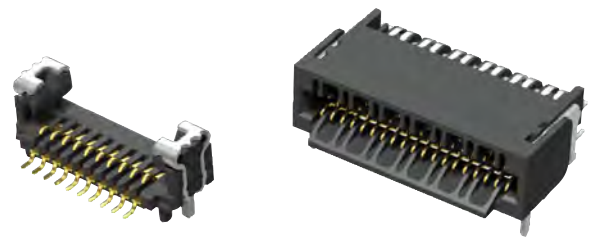

RUGGED MICRO FLYOVER® SOCKET SYSTEM

UEC5	NO. OF POSITIONS	DATA RATE	PLATING OPTION	D	RA	WELD TAB	OPTION	PACKAGING
------	------------------	-----------	----------------	---	----	----------	--------	-----------

	-019 (Per Row)	-1 = Up to 16 Gbps -2 = 28 Gbps+	-H = 30 μ" (0.76 μm) Gold on contact, Gold flash on tail (-1 Data Rate only) -H = 30 μ" (0.76 μm) Gold on contact, Matte Tin on tail (-2 Data Rate only) -HFL = 30 μ" (0.76 μm) Gold on contact, Gold flash on tail (-2 Data Rate only)			-1 = Through-hole -2 = Surface Mount (Data Rate -1 only)	Leave blank for -2 Data Rate -A = Alignment Pin (Available with Data Rate -1 only)	Leave blank for Tape & Reel -FR = Full Reel Tape & Reel (must order max. quantity per reel; contact Samtec for quantity breaks)
--	--------------------------	---	--	--	--	--	--	---

SPECIFICATIONS

Insulator Material:
Black LCP
Contact Material:
BeCu
Plating:
Au or Sn over
50 μ" (1.27 μm) Ni
Operating Temp Range:
-55 °C to +125 °C

PROCESSING

SMT Lead Coplanarity:
(0.10 mm) .004" max.

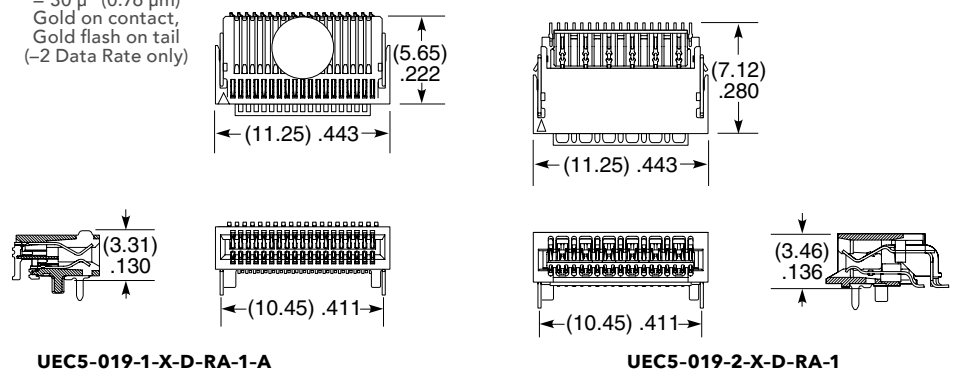

Note:
PCB footprints are not interchangeable for -1 and -2 data rate versions.

View complete specifications at: samtec.com?UEC5-1 & samtec.com?UEC5-2

UCC8	NO. OF POSITIONS	1	PLATING OPTION	S	WELD TAB	A	PACKAGING
------	------------------	---	----------------	---	----------	---	-----------

	-010		-H = 30 μ" (0.76 μm) Gold on contact, Gold flash on tail		-1 = Through-hole		Leave blank for Tape & Reel -FR = Full Reel Tape & Reel (must order max. quantity per reel; contact Samtec for quantity breaks)
--	-------------	--	--	--	-----------------------------	--	---

SPECIFICATIONS

Insulator Material:
Black LCP
Contact Material:
BeCu
Weld Tab:
Copper Alloy
Plating:
Au or Sn over
50 μ" (1.27 μm) Ni
Operating Temp Range:
-55 °C to +125 °C

PROCESSING

SMT Lead Coplanarity:
(0.10 mm) .004" max.

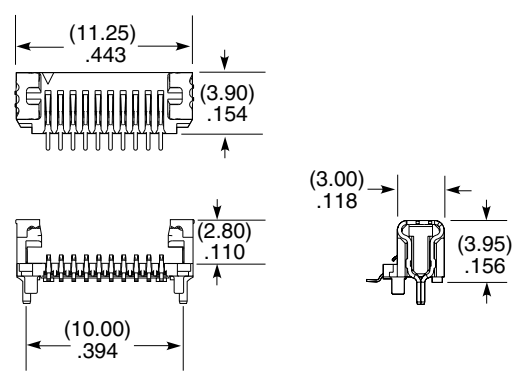

Note:
Some sizes, styles and options are non-standard, non-returnable.

View complete specifications at: samtec.com?UCC8



PCI EXPRESS
4.0 SOLUTIONS



PCIe®-OVER-FIBER ADAPTOR CARD

PCOA	DATA RATE	WIDTH	BRACKET
-------------	------------------	--------------	----------------

-G3
= 3.0 Speed
-G4
= 4.0 Speed

-S4
= Single x4
-D4
= Dual x4
-Q4
= Quad x4
-S8
= Single x8
-D8
= Dual x8 or Single x16

-0A
= Full Height

FEATURES

- Uses PCUO FireFly™ optical cable for clear signal transmissions with increased reach and cost optimization
- PCIe® x16 edge card connector
- Scalable configurations for cost optimized performance
- Transparent or non-transparent bridging for system flexibility and multi-processor support
- Reconfigurable host or target operation
- Ideal for high-performance and applications requiring robust data transmission

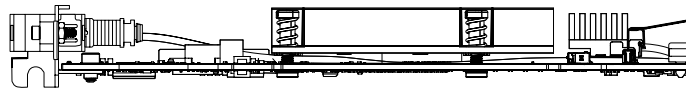
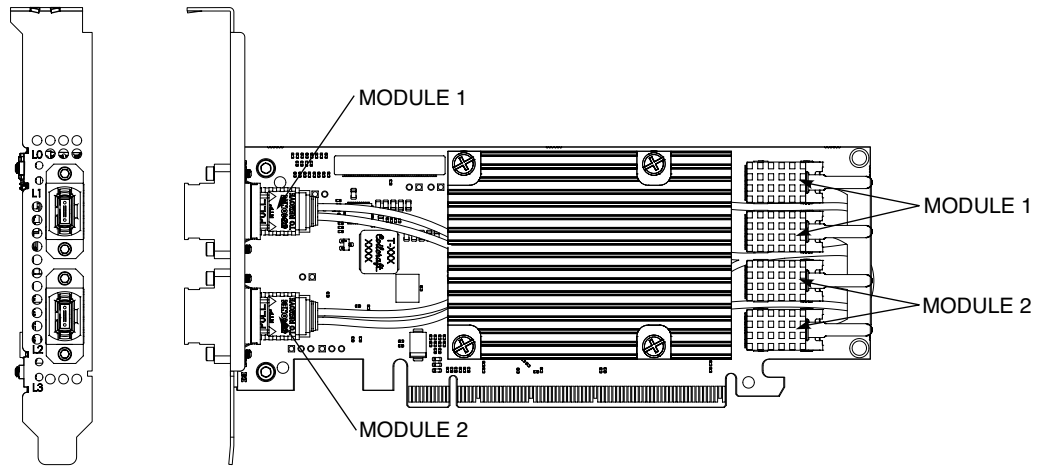

PCOA-G4-D8-0A SHOWN

CLASS 1 LASER PRODUCT
per IEC 60825-1 Ed. 3 (2014)

Notes:
Some lengths, styles and options are non-standard, non-returnable.

PCI-SIG®, PCI Express® and the PCIe® design marks are registered trademarks and/or service marks of PCI-SIG.

View complete specifications at: samtec.com?PCOA

OPTICAL PATCH CABLE AND ADAPTOR

FOPC	END 1	END 2	CABLE LENGTH	FIBERS	CONSTRUCTION
	-01 = MTP® Male	-01 = MTP® Male	-003 = 3 Meters	-12, -24	-01 = 3 mm Round Jacket
	-02 = MTP® Female	-02 = MTP® Female	-010 = 10 Meters		
			-100 = 100 Meters (Other lengths available as custom parts)		



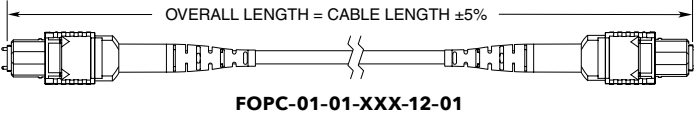

FOPC-01-01-XXX-12-01

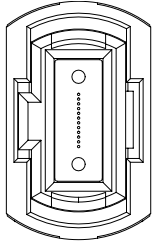

12 FIBER

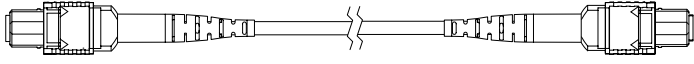

FOPC-02-02-XXX-24-01

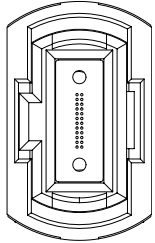

24 FIBER

SPECIFICATIONS

Compliant Specifications:
TIA-604-5-D (FOCIS 5)
TIA-568-C.3
IEC-61754-7-1

View complete specifications at: samtec.com?FOPC

OPA	PORTS	KEY	FLANGE
	-S = Single	-1 = Opposed	-F = Full
	-D = Double	-2 = Aligned	

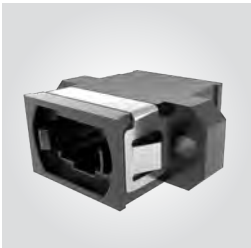

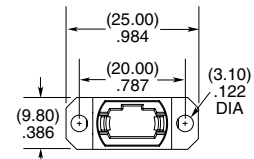

-S

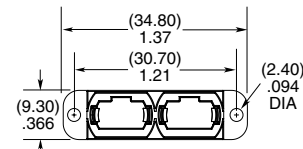

-D

SPECIFICATIONS

Compliant Specifications:
TIA-604-5-D (FOCIS 5)
IEC-61754-7

Recommended Panel Thickness:
(1.75 mm) .069"
(The OPA can be installed with any panel thickness but mounting hardware is needed for any thickness that is not (1.75 mm) .069". Contact the Optics Group at FireFly@samtec.com for questions about panel thickness and mounting hardware.)

View complete specifications at: samtec.com?OPA

Notes:
MTP® is a registered trademark of US ConneC Ltd.

Some lengths, styles and options are non-standard, non-returnable



HALO® NEXT GEN MID-BOARD OPTICAL TRANSCEIVERS

FEATURES & BENEFITS

- Designed for next gen embedded applications
- Up to 16 channels (x8 bidirectional)
- Low 6.35 mm profile for space savings
- Designed to withstand high shock and vibration
- Uses Samtec's proven AcceleRate® 2-piece contact system for high performance and reliability
- Features a low center of gravity for a stable connection to the board
- Optically pluggable for easy field replacement
- Protocol agnostic
- Supports data center, HPC and FPGA Protocols, including 10/40/100/400/800 Gb Ethernet, InfiniBand™, Fibre Channel, PCIe®, CXL® and Aurora
- Rugged socket connector features 76 pins around the perimeter for vertical mating
- Integrated locking latch mechanism simplifies mating/unmating of the cable assembly
- Halo® optical and Halo Cu™ copper systems are interchangeable using the same high-performance connector



The PCIe® design mark is a registered trademark and/or service mark of PCI-SIG.

112 Gbps PAM4 Halo Cu™
Copper Cable Assembly
Visit samtec.com?halo-pe

HALO® SOCKET CONNECTOR

HLF6	POSITIONS PER ROW	LEAD STYLE	PLATING OPTION	ROW OPTION	PACKAGING
	-38	-03.5 = 3.5 mm	-S = 30 μm (0.76 μm) Gold in contact area, Matte Tin on tail	-2 = 2 Row	-TR = Tape & Reel -FR = Full Reel Tape & Reel (must order max. quantity per reel; contact Samtec for quantity breaks)

HLF6
Mates:
HALO-C,
HALO-PE



PRELIMINARY

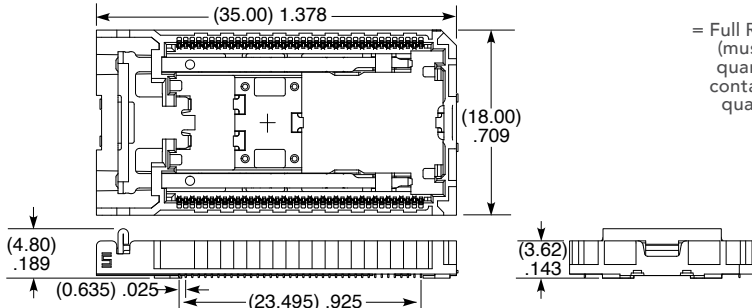

View complete specifications at: samtec.com?HLF6

HALO® MID-BOARD OPTICAL TRANSCEIVERS

HALO

C

B08

DATA RATE

HEAT SPREADER

1

PRELIMINARY

-1
= 28 Gbps NRZ
-3
= 56 Gbps PAM4

-1
= Flat

SPECIFICATIONS

Power Supply Voltage:
1.6 V, 3.3 V, 4.1 V
Storage Temperature:
-40 °C to +85 °C
Operating Temperature:
0 °C to +70 °C
Relative Humidity:
5 to 85%
Transmitter Type:
850 nm VCSEL

**HALO-C
Mates:**
HLF6

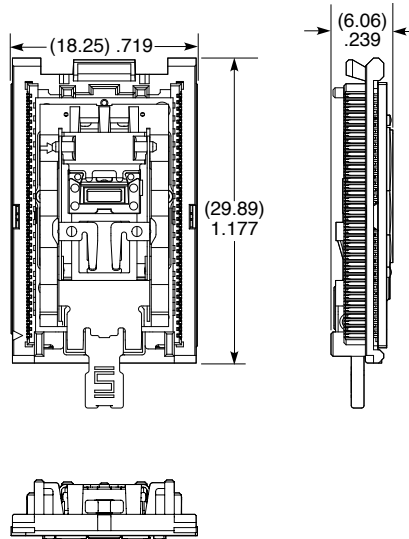
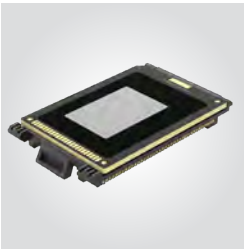

HALO-C-B08-X-1-1 SHOWN

OTHER SOLUTIONS

Variety of heat sink options for conduction, convection or liquid cooling thermal relief; contact OpticsOTP@samtec.com

View complete specifications at: samtec.com?HALO-C

FIREHAWK™ SPACE, MID-BOARD OPTICAL TRANSCEIVERS

- Designed to withstand the vibrations and radiation in space/satellite applications
- Smallest footprint and lowest profile in the industry (10 x 7.7 x 4.4)
- 0.4 grams total weight for optimal SWaP
- Extreme performance to 40 Gbps aggregate
- SI Evaluation Kit available, visit samtec.com/kits
- Part Number: CSSO-B04-10-4-0-0-2-2*
- Visit samtec.com/firehawk for more information



10
Gbps

* For full assembly, purchase of RVCON® optical cable and CSSO mid-board optical transceiver are necessary. Contact Optics@samtec.com for assistance.

OPTICS EVALUATION & DEVELOPMENT KITS

From concept and prototype to development and production, Samtec-designed kits and boards simplify design and reduce time to market. For more information, please visit samtec.com/kits or contact KitsAndBoards@samtec.com.

28 Gbps FireFly™ Evaluation Kits

Easy-to-use platform for testing and real-time evaluation of the FireFly™ Micro Flyover System™. These kits support copper or optical FireFly™ in x4 or x12 configurations.
(Samtec P/N: REF-209623-01 and REF-230408-X.XX-01)

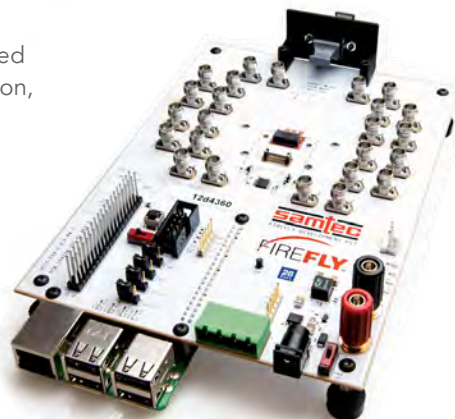

14 Gbps FireFly™ FMC Development Kit

VITA™ 57.1 electrically compliant and provides up to 140 Gbps full-duplex bandwidth over 10 channels from an FPGA to an industry-standard multi-mode fiber optic cable.
(Samtec P/N: REF-193429-01)



25/28 Gbps FireFly™ FMC+ Development Kit

VITA™ 57.4 electrically compliant and provides up to 400/448 Gbps full-duplex bandwidth over 16 channels from an FPGA to an industry-standard multi-mode fiber optic cable.
(Samtec P/N: REF-200772-XXX-XX-01)

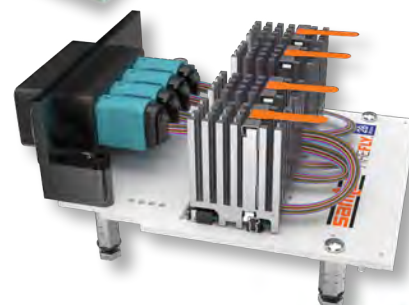

FireBlade™ OCP OAI EXP Module

Provides low-latency, protocol agnostic, 1.6 Tbps aggregate throughput leveraging 16 low-power 25 Gbps x4 FireFly™ mid-board optical transceivers in a compact form factor ideal for AI/ML system topologies.

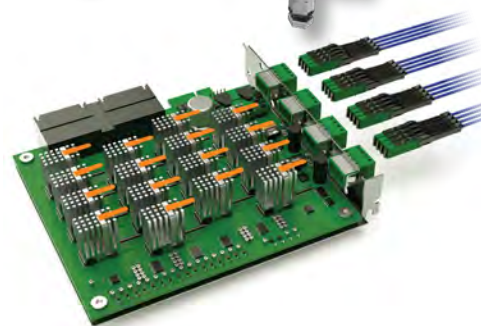

FireHawk® Evaluation Kits

Real-time evaluation of FireHawk® rugged optical transceivers in a lab or benchtop setting. Rated to 10 Gbps and 25 Gbps per lane in a x4 configuration, the transceivers combine extreme density with extreme performance to meet the harshest environments.
(Samtec P/N: REF-231561-X.XX-XX)

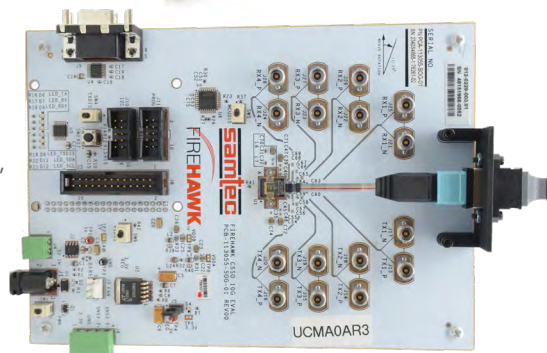

VITA/VNX/VNX+/FMC/FMC+/XMC/XMC+ are all respective trademarks of VITA

RF/PRECISION RF

CABLE ASSEMBLIES • CONNECTORS • ORIGINAL SOLUTIONS • TECHNICAL SUPPORT

CABLE ASSEMBLIES

150-180

Precision RF 50 Ω
(18 GHz to 110 GHz)

182-194

Standard RF 50 Ω & 75 Ω
(Sub-6 GHz & 12G-SDI)



CABLE CONNECTORS

157-171

Precision RF 50 Ω
(18 GHz to 110 GHz)

184-194

Standard RF 50 Ω & 75 Ω
(Sub-6 GHz & 12G-SDI)



BOARD CONNECTORS

157-169

Precision RF 50 Ω
(18 GHz to 110 GHz)

184-194

Standard RF 50 Ω & 75 Ω
(Sub-6 GHz & 12G-SDI)



ADAPTORS

172-173

Precision RF 50 Ω
(In-Series & Between-Series)



ORIGINAL RF SOLUTIONS

155

Precision RF

195

Low Frequency

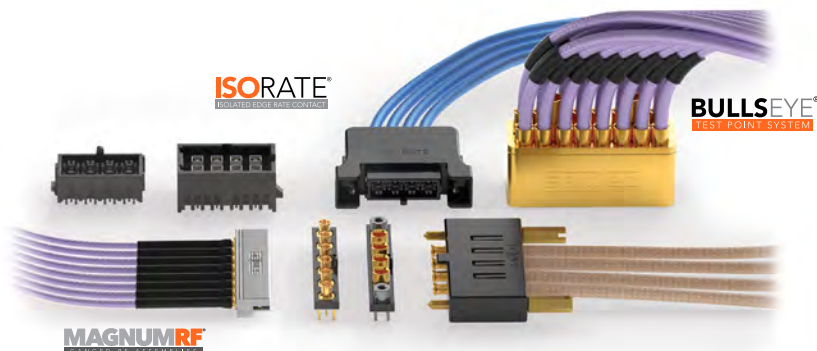

Nitrowave™ High-Performance Microwave Cables	151-154
Magnum RF® Solutions for Ganged Cable-to-Board or Board-to-Board Applications	164-165
Bulls Eye® Solutions for 40 GHz, 50 GHz, 70 GHz, 71 GHz & 90 GHz	174-177
Rugged, Blind Mate Modular Solutions to 110 GHz	178-179
Flexible Waveguide Technology for Frequencies up to 75 GHz (V-band)	180
Customs & Tech Support	196

COMPLETE RF INTERCONNECT SOLUTIONS

PRECISION 50 Ω (18 to 110 GHz) • STANDARD 50 Ω & 75 Ω (SUB-6 GHz & 12G-SDI) • TECH SUPPORT

Samtec offers complete RF interconnect solutions supporting traditional sub-6 GHz frequencies to 110 GHz microwave/mmWave frequencies (sub-Terahertz spectrum). Products include end-to-end RF cable assemblies, board connectors, cable connectors, adaptors and Samtec Original RF solutions.

Technical Support

High-level design and development of advanced interconnect systems, along with industry leading expertise, allows effective strategies and support for optimizing the entire signal channel.

RF technical support includes launch optimization, simulation and testing. Customization of products, both quick-turn modifications or new designs, is also available.

Applications

- Test and Measurement
- Military, Aerospace, Satellite, Radar
- 5G/6G, Low Latency Wireless Communications
- Automotive, Telematics
- Broadcast & 12G-SDI
- Industrial, Monitoring, Instrumentation

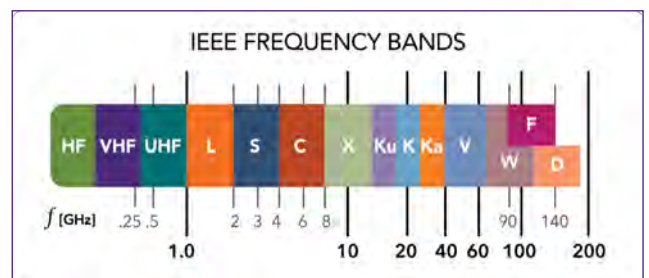
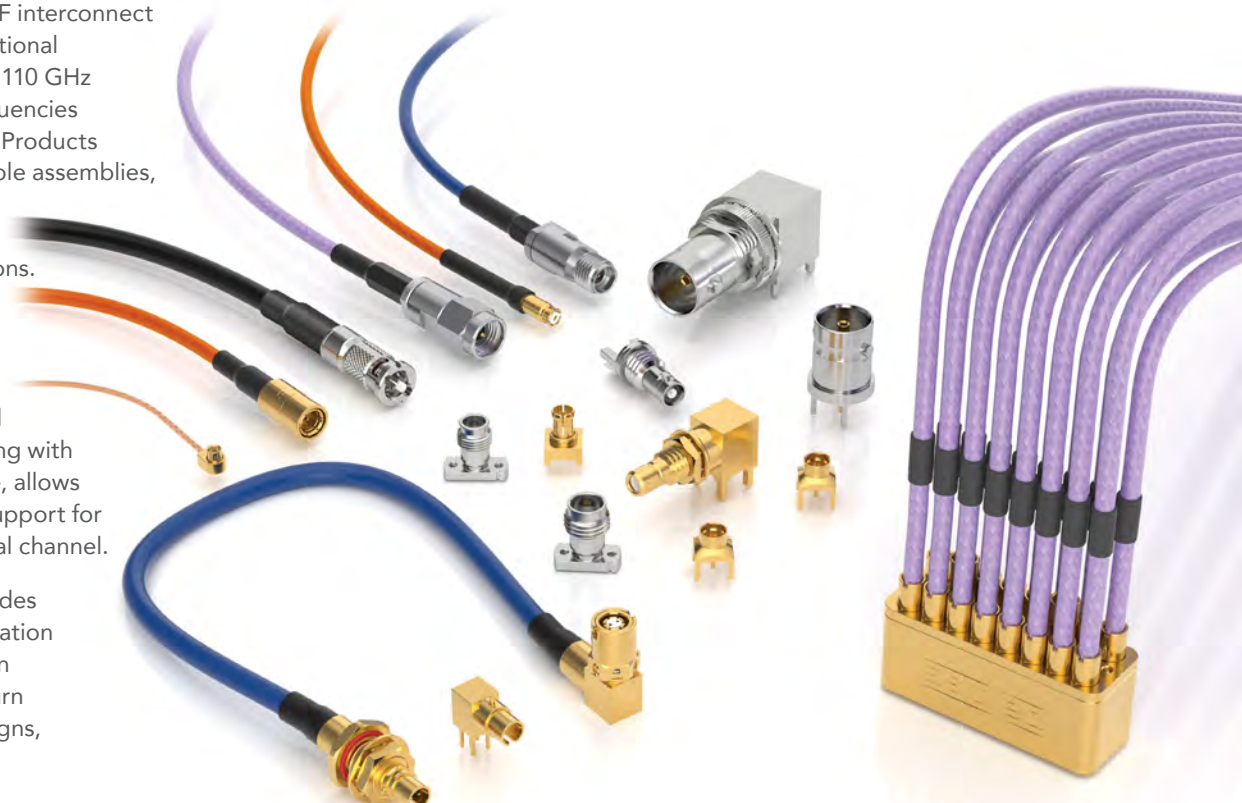

PRECISION RF, 50 Ω

Interface	1.00 mm	1.35 mm	1.85 mm	2.40 mm	2.92 mm	3.50 mm	SSMA	SMA	Ganged SMPM	SMPM	SMP	N Type	TNCA
Frequency	110 GHz	90 GHz	65 GHz	50 GHz	40 GHz	34 GHz	34 GHz	18/26.5 GHz	65 GHz	65 GHz	40 GHz	18 GHz	18 GHz

STANDARD RF, 50 Ω & 75 Ω

Interface	MHF	SMA	MCX	MMCX	TNC	BNC (50 Ω)	SMB (50 & 75 Ω)	Ganged (50 & 75 Ω)	BNC (75 Ω)	HD BNC (75 Ω)	DIN 1.0/2.3 (75 Ω)
Frequency	6 GHz	6 GHz	6 GHz	6 GHz	6 GHz	4 GHz	4 GHz	5 GHz	12 GHz	12 GHz	12 GHz

CABLE ASSEMBLIES

- Precision, high frequency or standard, low frequency
- Assemblies available with the following cable types:
 - Low-loss microwave/millimeter wave from .047 to .277, semi-flexible
 - New **Nitrowave™** cable! Phase and amplitude stable with flexure, with an outer jacket colored in **distinctive Samtec orange**. Performance is optimized for next generation frequency targets.
 - Armored versions for crush, torque and pull resistance
 - RG type (316, 174, 178, 58, 179, 6)
 - 12G-SDI optimized
 - 0.81 mm and 1.13 mm Micro High Frequency (MHF)
- Discrete and ganged solutions
- Cable lengths standard up to 10 meters (> 10 meters as custom RSP)
- Phase matching in pairs down to 1 ps
- Cable management available
- **Mix & Match Solutions for Any Application:** Samtec offers a variety of end options for each product series; this blends application-specific customization with the simplicity and lead-time efficiencies of an off-the-shelf assembly



BOARD CONNECTORS, CABLE CONNECTORS & ADAPTORS

- Precision, high frequency or standard, low frequency solutions
- Board-to-board or cable-to-board applications
- Threaded, bulkhead, push-on or bayonet coupling
- Solderless compression mount: vertical & edge launch
- Soldered: through-hole, surface mount, edge mount or mixed technology
- Balanced connectors for high-volume pick-and-place automation
- 12G-SDI optimized broadcast video solutions (BNC, High-Density BNC, DIN 1.0/2.3)
- Cable connectors for use with industry standard cables: offer the flexibility to terminate to an industry-standard cable specified for your application
- Adaptors for 50 Ω precision RF applications: in-series and between-series



Ganged Solutions



Complete Mated Sets



50 Ω , 75 Ω & 12G-SDI Solutions



Precision Interconnects

PRECISION RF

MICROWAVE / MILLIMETER WAVE CABLE ASSEMBLIES & INTERCONNECTS

Samtec's RF product line includes 18 to 110 GHz High Frequency, Precision RF solutions for microwave and mmWave applications, including end-to-end cable assemblies, adaptors, cable connectors and board level interconnects. Our focus is on delivering high-quality RF products that meet precision and performance expectations, blended with industry-leading system-level signal integrity expertise.

Vertical Integration

=

Full System Support

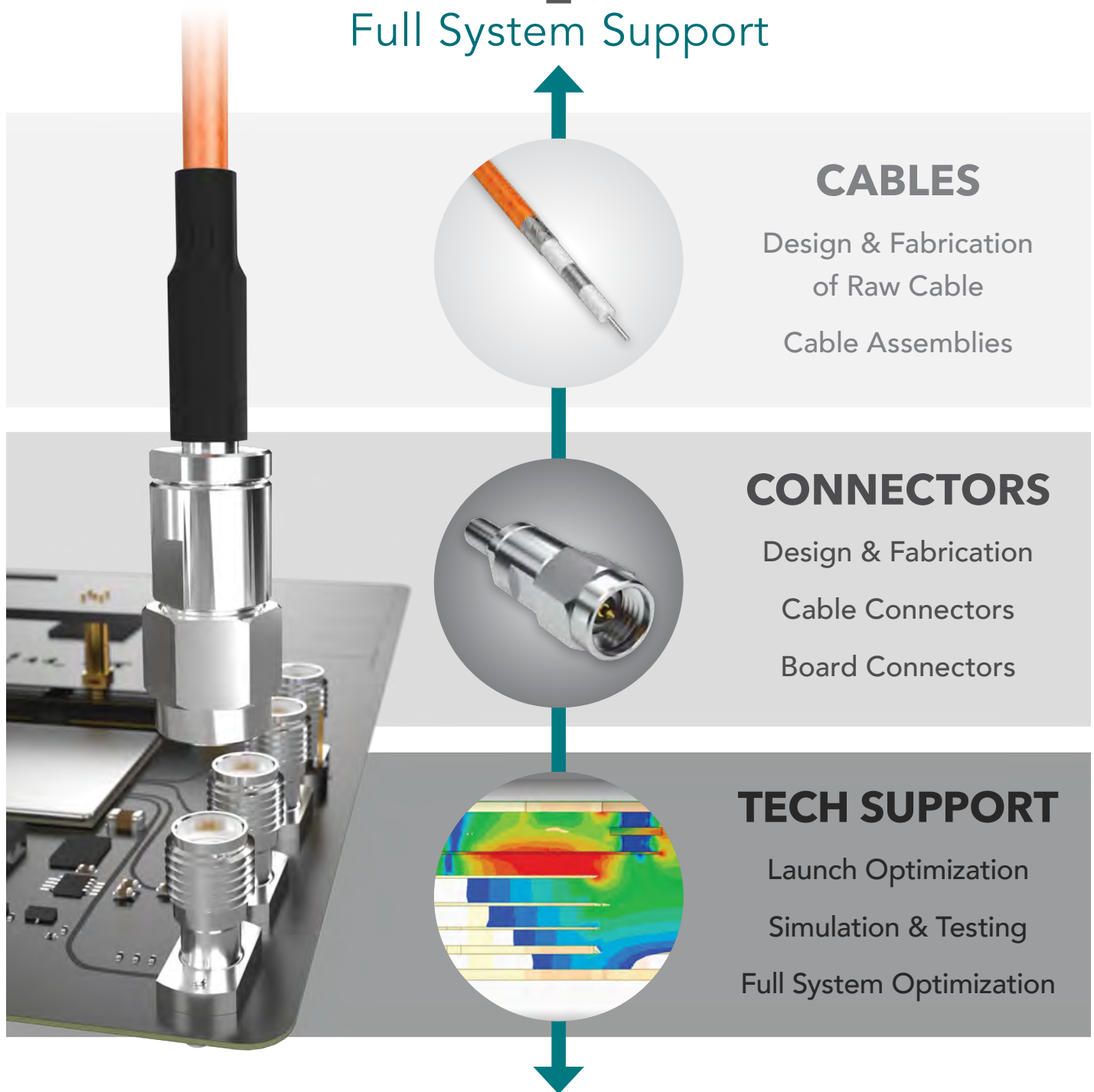

NITROWAVE™ CABLE TECHNOLOGY

HIGH-PERFORMANCE, PHASE & AMPLITUDE STABLE

DC TO
110
GHz

Samtec's new **Nitrowave™ Phase & Amplitude Stable RF Cable** offers improved stability with flexure. The coaxial structure – with an outer jacket colored in **distinctive Samtec orange** – is designed to meet the demands of aerospace, defense, datacom, computer/semiconductor, and instrumentation markets. Performance is optimized at frequencies beyond traditional industry targets to support emerging applications.

NITROWAVE™ CABLE TECHNOLOGY

- High-performance, low-loss microwave cable assemblies
- Phase and amplitude stable with flexure
- Consistent contact resistance between layers
- Lower density dielectric minimizes loss
- State-of-the-art shielding techniques and Dynamic Performance Layer (DPL)
- Silver plating enhancements mitigate corrosion potential
- Electrical performance optimized at next gen frequencies (GHz): 18, 32, 43.5, 71, 95, 110
- Mechanical and environmental robustness
- Typical phase vs. temp & power handling
- For armored cable versions for crush, torque and pull resistance, contact RFGroup@samtec.com



Series	LL018	LL032	LL043*	LL071	LL095	LL110
Impedance (Ω)	50					
Max Frequency (GHz)	18	32	43.5	71	95	110
Outer Dia. (inches)	0.309	0.182	0.141	0.094	0.076	0.068
Min Static Bend Radius	1.25	0.375	0.25	0.125	0.156	0.156
Velocity of Propagation (%)	77					
Min Shielding Effectiveness (dB)	-90					
Temp Range (°C)	-65 °C to +125 °C					
Insertion Loss	See Maximum IL Chart					
End 1/End 2	1.00 mm, 1.35 mm, 1.85 mm, 2.40 mm, 2.92 mm, SMPM, SMP, SMA, N Type, TNCA					

MAXIMUM INSERTION LOSS (dB/m)

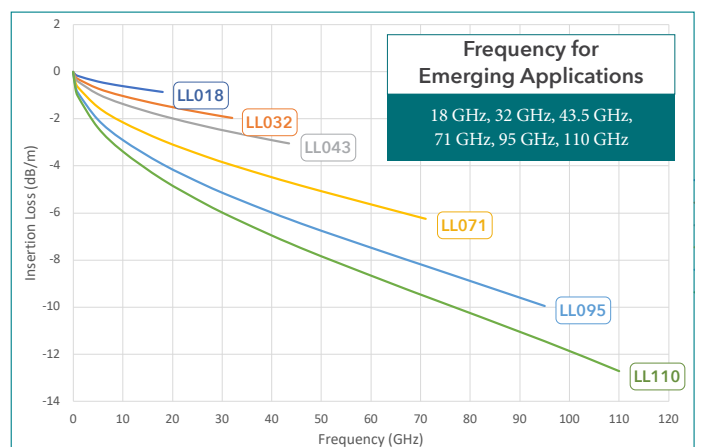

HIGH-PERFORMANCE MICROWAVE CABLE

Cable Assemblies
LL110



FEATURES

Impedance:
50 Ω
Outer Diameter:
0.068"
Bend Radius:
0.156"
Velocity of Propagation:
77 %
Min. Shielding Effectiveness:
-90 dB
Temp Range:
-65 °C to +125 °C

SERIES	END 1 CONNECTOR	END 2 CONNECTOR	OVERALL LENGTH	PHASE MATCHING	PHASE MATCHING CABLES
--------	-----------------	-----------------	----------------	----------------	-----------------------

LL110
= High-Performance Cable to 110 GHz

Specify END OPTIONS from chart

–“XXXX”
= Overall Length in millimeters
–0100 (100 mm)
3.94" min.

Leave blank for no phase matching

- 1 = 1 Pico Second
- 2 = 2 Pico Seconds
- 5 = 5 Pico Seconds

Leave blank for 1 cable. (Only available with no phase matching option)

–02 to 16
= No. of cables

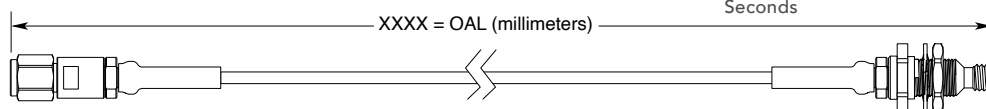

LL110-10SP-10BJ-XXXX-X-XX

END OPTION	INTERFACE TYPE	GENDER	MAXIMUM RETURN LOSS (PER END)	MAXIMUM VSWR (PER END)	FREQUENCY
–10SP	1.00 mm	PLUG	13.97	1.50	DC TO 110 GHz
–10BJ	1.00 mm	BULKHEAD JACK	13.97	1.50	

Cable Assemblies
LL095



FEATURES

Impedance:
50 Ω
Outer Diameter:
0.076"
Bend Radius:
0.156"
Velocity of Propagation:
77 %
Min. Shielding Effectiveness:
-90 dB
Temp Range:
-65 °C to +125 °C

SERIES	END 1 CONNECTOR	END 2 CONNECTOR	OVERALL LENGTH	PHASE MATCHING	PHASE MATCHING CABLES
--------	-----------------	-----------------	----------------	----------------	-----------------------

LL095
= High-Performance Cable to 95 GHz

Specify END OPTIONS from chart

–“XXXX”
= Overall Length in millimeters
–0100 (100 mm)
3.94" min.

Leave blank for no phase matching

- 1 = 1 Pico Second
- 2 = 2 Pico Seconds
- 5 = 5 Pico Seconds

Leave blank for 1 cable. (Only available with no phase matching option)

–02 to 16
= No. of cables

–MOSJ
PRELIMINARY

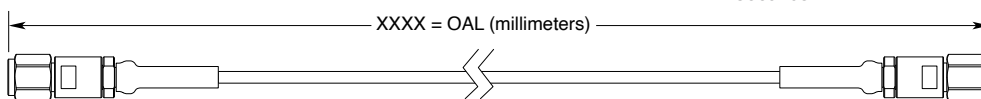

LL095-10SP-10SP-XXXX-X-XX

END OPTION	INTERFACE TYPE	GENDER	MAXIMUM RETURN LOSS (PER END)	MAXIMUM VSWR (PER END)	FREQUENCY
–10SP	1.00 mm	PLUG	19.90	1.225	DC TO 95 GHz
–MOSJ	SMPM	JACK	19.90	1.225	DC TO 65 GHz

HIGH-PERFORMANCE MICROWAVE CABLE

Cable Assemblies LL071



FEATURES

Impedance:
50 Ω
Outer Diameter:
0.094"
Bend Radius:
0.125"
Velocity of Propagation:
77 %
Min. Shielding Effectiveness:
-90 dB
Temp Range:
-65 °C to +125 °C

SERIES	END 1 CONNECTOR	END 2 CONNECTOR	OVERALL LENGTH	PHASE MATCHING	PHASE MATCHING CABLES
LL071 = High-Performance Cable to 71 GHz	Specify END OPTIONS from chart		-"XXXX" = Overall Length in millimeters -0100 (100 mm) 3.94" min.	Leave blank for no phase matching -1 = 1 Pico Seconds -2 = 2 Pico Seconds -5 = 5 Pico Seconds	Leave blank for 1 cable. (Only available with no phase matching option) -02 to 16 = No. of cables

XXXX = OAL (millimeters)

LL071-18SP-18BJ-XXXX-X-XX

END OPTION	INTERFACE TYPE	GENDER	MAXIMUM RETURN LOSS (PER END)	MAXIMUM VSWR (PER END)	FREQUENCY
-18SP	1.85 mm	PLUG	21.53	1.183	DC TO 71 GHz
-18BJ	1.85 mm	BULKHEAD JACK	21.53	1.183	DC TO 71 GHz
-92SP	2.92 mm	PLUG	21.53	1.183	DC TO 43.5 GHz

Cable Assemblies LL043



FEATURES

Impedance:
50 Ω
Outer Diameter:
0.141"
Bend Radius:
0.25"
Velocity of Propagation:
77 %
Min. Shielding Effectiveness:
-90 dB
Temp Range:
-65 °C to +125 °C

SERIES	END 1 CONNECTOR	END 2 CONNECTOR	OVERALL LENGTH	PHASE MATCHING	PHASE MATCHING CABLES
LL043 = High-Performance Cable to 43.5 GHz	Specify END OPTIONS from chart		-"XXXX" = Overall Length in millimeters -0100 (100 mm) 3.94" min.	Leave blank for no phase matching -1 = 1 Pico Second -2 = 2 Pico Seconds -5 = 5 Pico Seconds	Leave blank for 1 cable. (Only available with no phase matching option) -02 to 16 = No. of cables

XXXX = OAL (millimeters)

LL043-92SP-92BJ-XXXX-X-XX

END OPTION	INTERFACE TYPE	GENDER	MAXIMUM RETURN LOSS (PER END)	MAXIMUM VSWR (PER END)	FREQUENCY
-92SP	2.92 mm	PLUG	21.53	1.183	DC TO 43.5 GHz
-92BJ	2.92 mm	BULKHEAD JACK	21.53	1.183	DC TO 43.5 GHz
-24SP	2.40 mm	PLUG	21.53	1.183	DC TO 43.5 GHz
-24BJ	2.40 mm	BULKHEAD JACK	21.53	1.183	DC TO 43.5 GHz
-01SP	SMA	PLUG	21.53	1.183	DC TO 26.5 GHz
-01BJ	SMA	BULKHEAD JACK	21.53	1.183	DC TO 26.5 GHz

HIGH-PERFORMANCE MICROWAVE CABLE

Cable Assemblies
LL032



SERIES	END 1 CONNECTOR	END 2 CONNECTOR	OVERALL LENGTH	PHASE MATCHING	PHASE MATCHING CABLES
--------	-----------------	-----------------	----------------	----------------	-----------------------

LL032
= High-Performance Cable to 32 GHz

Specify **END OPTION** from chart

-"XXXX"
= Overall Length in millimeters
-0100 (100 mm) 3.94" min.

Leave blank for no phase matching

-1
= 1 Pico Second

-2
= 2 Pico Seconds

-5
= 5 Pico Seconds

Leave blank for 1 cable. (Only available with no phase matching option)

-02 to 16
= No. of cables

FEATURES

- Impedance:** 50 Ω
- Outer Diameter:** 0.182"
- Bend Radius:** 0.375"
- Velocity of Propagation:** 77 %
- Min. Shielding Effectiveness:** -90 dB
- Temp Range:** -65 °C to +125 °C

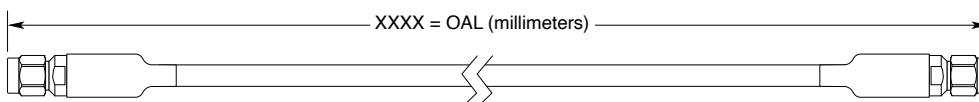

LL032-92SP-92SP-XXXX-X-XX

END OPTION	INTERFACE TYPE	GENDER	MAXIMUM RETURN LOSS (PER END)	MAXIMUM VSWR (PER END)	FREQUENCY
-92SP	2.92 mm	PLUG	21.53	1.183	DC TO 32 GHz

Cable Assemblies
LL018



SERIES	END 1 CONNECTOR	END 2 CONNECTOR	OVERALL LENGTH
--------	-----------------	-----------------	----------------

LL018
= High-Performance Cable to 18 GHz

Specify **END OPTION** from chart

-"XXXX"
= Overall Length in millimeters
-0100 (100 mm) 3.94" minimum

PRELIMINARY

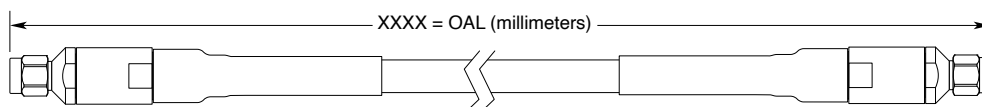

LL018-01SP-01SP-XXXX

END OPTION	INTERFACE TYPE	GENDER	MAXIMUM RETURN LOSS (PER END)	MAXIMUM VSWR (PER END)	FREQUENCY
-01SP	SMA	PLUG	22.51	1.162	DC TO 18 GHz

FEATURES

- Impedance:** 50 Ω
- Outer Diameter:** 0.309"
- Bend Radius:** 1.25"
- Velocity of Propagation:** 77 %
- Min. Shielding Effectiveness:** -90 dB
- Temp Range:** -65 °C to +125 °C

ORIGINAL SOLUTIONS PRECISION RF

PRECISION ALIGNMENT FEATURES

- Eliminates misalignment that can occur during board assembly
- Ensures repeatable peak connector performance
- Available on 135, 185, 240, 292 & GPPC-CMM Series

DIFFERENTIAL PAIR TEST & MEASUREMENT

- Two-port SMPM ganged solution (GPPC-CMM Series)
- Solderless compression mount design
- Saves board real estate (2x the spacing savings)
- Cable-to-board or board-to-board

RIGHT-ANGLE, LOW PROFILE, GANGED SMPM

- Extremely low profile, high-density, right-angle connector (GPPC-RA-SM Series)
- Belly-to-belly, surface mount PCB connection for maximum density
- Body height: 3.94 mm (.155")

COUNTERWEIGHT SOLUTIONS

- Enables efficient board assembly (eliminates hand soldering)
- Balanced for automated, high-volume pick-and-place automation
- Edge mount SMA (26.5 GHz) or 2.92 mm (40 GHz)

ANALOG OVER ARRAY™ CONNECTORS

- Enhanced open-pin-field arrays simultaneously run analog, digital, and power signals
- Reference designs and evaluation kits
- Industry-leading crosstalk and return loss performance

DC TO
90
GHz

DC TO
65
GHz

DC TO
65
GHz

DC TO
40
GHz

DC TO
36
GHz



MAGNUMRF
GANGED RF ASSEMBLIES

Precision Alignment Features

SERIES	135/185/240/292/GPPC	GPPC-CMM	GPPC-RA-SM	RSP (SMA/2.92 mm)	ANALOG OVER ARRAY™
Application	Precision Alignment	Differential Pair Testing	Extremely Low Profile	Balanced Edge Mount	Analog, Digital & Power
URL	samtec.com/alignment	samtec.com?GPPC-CMM	samtec.com?GPPC-RA-SM	Contact: RFGroup@samtec.com	samtec.com/AOA
PRODUCT FAMILY	BULLS EYE®	FLEXIBLE WAVEGUIDE	RUGGED BLIND MATE	MAGNUM RF®	
URL	samtec.com/BullsEye	samtec.com/Waveguide	samtec.com/blind-mate	samtec.com/magnumRF	

VITA/VNX/VNX+/FMC/FMC+/XMC/XMC+/QMC are all respective trademarks of VITA

50 Ω μWAVE/mmWAVE CABLE SPECIFICATIONS

STANDARD OFF-THE-SHELF ASSEMBLIES

SERIES	RF047-A	RF25S	RF40S	RF085	RF086	RF23C	RF23S	RF402	RF180	RF280	
TYPE	.047 (29 AWG), low loss flexible	Samtec 25 AWG, flexible	RG 40S, .086, (24 AWG), semi- flexible	.085 (24 AWG), low loss flexible	.086 (23 AWG), low loss flexible	Samtec 23 AWG, flexible, copper shield	Samtec 23 AWG, flexible	RG 402, .141 (19 AWG), semi- flexible	.178 (16 AWG), low loss flexible	.277 (11 AWG), low loss flexible	
ELECTRICAL											
Max. Frequency (GHz)	110	40	20	50	67	50	35	20	27	18	
Max. Insertion Loss (dB/m)	1 GHz	1.21	0.79	0.72	0.69	0.65	0.68	0.72	0.40	0.27	0.17
	26 GHz	7.43	3.80 @ 20 GHz	4.26 @ 20 GHz	4.28	3.90	4.27	3.71 @ 20 GHz	2.30 @ 20 GHz	1.23 @ 18 GHz	0.79 @ 18 GHz
	40 GHz	9.68	–	–	5.59	5.06	5.59	–	–	–	–
	50 GHz	11.14	–	–	6.47	5.81	6.46	–	–	–	–
Propagation Delay (ns/m)	4.76		4.79	4.75	4.20	4.76	4.72	4.79	4.17	4.02	
Velocity of Propagation	70%				80%	70%		70%	80%	83%	
Capacitance (pF/m)	95.00	96.80	104.97	88.20	83.37	97.80	95.45	98.07	82.00		
CONSTRUCTION											
Center Conductor	Material	Solid Silver Plated Copper									
	AWG (mm/in.)	29 (.2870 / .0113)	25 (.4570 / .0180)	24 (.5100 / .0200)		23 (.5740 / .0226)			19 (.9200 / .0362)	16 (1.3000 / .0512)	11 (2.2600 / .0889)
Dielectric	Material	PFA	Solid FEP	PTFE	Solid PTFE	Foam FEP	FEP	Solid FEP	PTFE	PTFE Tape	
	Dia. (mm/in.)	.9220 / .0363	1.4700 / .0578	1.6800 / .0660	1.6300 / .0640	1.6150 / .0636	1.8470 / .0727	1.8470 / .0727	2.9800 / .1170	3.6800 / .1450	6.3500 / .2500
Shield	Material	1) Ag Plated Cu 2) Ag Plated Cu		Tinned Cu	Spiral Strip Ag Plated Cu	1) Ag Plated Cu 2) Ag Plated Cu	1) Ag Plated Cu 2) Cu Tape 3) Ag Plated Cu	1) Ag Plated Cu 2) Ag Plated Cu	Tinned Cu	1) Flat Ag Plated Cu 2) Al Polyester 3) Round Ag Plated Cu	
Outer Braid	Dia. (mm/in.)	1.1700 / .0460	1.8600 / .0735	2.2000 / .0860	2.1300 / .0840	2.1080 / .0830	2.2730 / .0895	2.2480 / .0885	3.5800 / .1410	4.5200 / .1780	7.0400 / .2770
Jacket	Material	FEP		–	FEP			–	FEP		
	Dia. (mm/in.)	1.4200 / .0560	2.0600 / .0810	3.2000 / .1260	2.6400 / .1040	2.5400 / .1000	2.6670 / .1050	2.5900 / .1020	4.5800 / .1803	4.9500 / .1950	7.6200 / .3000
MECHANICAL											
Operating Temp	-65° C to 125° C	-40° C to 200° C	-40° C to 125° C	-65° C to 125° C	-55° C to 125° C	-65° C to 125° C	-40° C to 200° C	-40° C to 150° C	-55° C to 200° C		
Min. Bend Radius	3.18 mm	9.00 mm	6.35 mm	13.20 mm	8.90 mm	3.18 mm	8.89 mm	10.90 mm	24.80 mm	38.10 mm	
Connector Options	1.00 mm, 1.35 mm, 1.85 mm, 2.40 mm, 2.92 mm, SMA, SMP, SMPM, Ganged SMPM (Magnum RF®)	SMA, SMP		2.92 mm, 2.40 mm	1.85 mm, 2.40 mm, 2.92 mm, SMA, SMP, SMPM, Ganged SMPM (Magnum RF®)	2.40 mm, 2.92 mm, SMA, SMP, SMPM	3.50 mm	SMA	SMA, TNCA, N Type	SMA, TNCA, N Type	

For complete specifications, visit samtec.com or contact RFGroup@samtec.com

1.00 mm TO 110 GHz

1.00 mm Cable Assemblies RF047-A



SERIES	END 1 CONNECTOR	END 2 CONNECTOR	OVERALL LENGTH
RF047-A = (1.2 mm) .047" overshield DIA 29 AWG millimeter wave cable	-10BJ = 1.00 mm Bulkhead Straight Jack -10SP = 1.00 mm Straight Plug		-“XXXX” = Overall Length in millimeters -0100 (100 mm) 3.94" minimum

ALSO AVAILABLE

1.35 mm, 1.85 mm, 2.40 mm, 2.92 mm,
SMPM, SMP, SMA = RF047-A

VSWR

1.40 max. (DC to 90 GHz)
1.50 max. (90 GHz to 110 GHz)

1.00 mm Board Connectors 100

Cable Mates: RF047-A



100	GENDER	TYPE	PLATING	ORIENTATION	TERMINATION	OPTION	PACKAGING
	-J = Jack	-P = PCB Mount	-VP = 50 μ" (1.27 μm) Gold center contact, Passivated outer body	-ST = Straight	-EL = Edge Launch	-01 = .040" to .100" PCB thickness	Leave blank for Individually bagged -B = Bulk packaged

PRELIMINARY

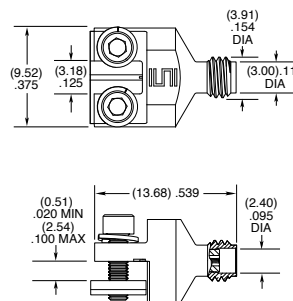

1.00 mm Cable Connectors PRF10



CONNECTORS FOR INDUSTRY STANDARD CABLES	
PRF10-J-C-VP-.047D-SS	.047 Semi-Rigid
PRF10-P-C-VP-.047D-SS	.047 Semi-Rigid

For a complete list of 1.00 mm cable connectors, visit www.samtec.com?PRF10
J-C = Cable Jack
P-C = Cable Plug
VP = Plating (75 μ" Gold center contact, passivated outer contact)
SS = Straight, Solder Clamp

INTERFACE STANDARD

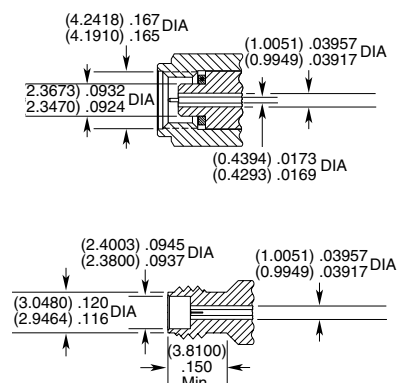

1.35 mm TO 90 GHz

1.35 mm Cable Assemblies RF047-A



SERIES	END 1 CONNECTOR	END 2 CONNECTOR	OVERALL LENGTH
RF047-A = (1.2 mm) .047" overshield DIA 29 AWG millimeter wave cable	-13BJ = 1.35 mm Bulkhead Straight Jack -13SP = 1.35 mm Straight Plug		-“XXXX” = Overall Length in millimeters -0100 (100 mm) 3.94" minimum

ALSO AVAILABLE

1.00 mm, 1.85 mm, 2.40 mm, 2.92 mm,
SMPM, SMP, SMA = RF047-A

VSWR

RF047-A: 1.40 max.

1.35 mm Board Connectors 135

Cable Mates:
RF047-A



135	GENDER	TYPE	PLATING	ORIENTATION	TERMINATION	OPTION	PACKAGING
	-J = Jack	-P = PCB Mount	-VP = 50 μ" (1.27 μm) Gold center contact, Passivated outer contact	-ST = Straight	-CM = Compression Mount Stripline -CMM = Compression Mount Microstrip	-1 = Without screws -2 = With screws	Leave blank for individually bagged. -B = Bulk packaged

-CMM

-CM

1.35 mm Cable Connectors PRF13



CONNECTORS FOR INDUSTRY STANDARD CABLES	
PRF13-P-C-VP-047A-SS	Temp-Flex 1000671047
PRF13-J-C-VP-047A-BS	Temp-Flex 1000671047

For a complete list of 1.35 mm cable connectors, visit www.samtec.com?PRF13

- P-C = Cable Plug
- J-C = Cable Jack
- VP = Plating (75 μ" Gold center contact, passivated outer contact)
- SS = Straight, Solder Clamp
- BS = Bulkhead, Solder Clamp

INTERFACE STANDARD

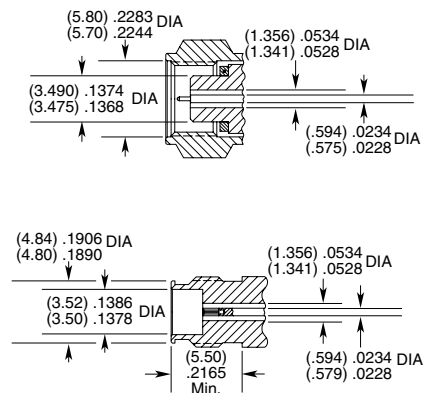

1.85 mm TO 65 GHz

1.85 mm Cable Assemblies

RF047-A, RF086



VSWR

RF047-A: 1.40 max.
RF086: 1.40 max.

SERIES	END 1 CONNECTOR	END 2 CONNECTOR	OVERALL LENGTH
RF047-A = (1.2 mm) .047" overshield DIA 29 AWG millimeter wave cable RF086 = (2.18 mm) .086" overshield DIA 23 AWG millimeter wave cable	-18SJ = 1.85 mm Straight Jack -18SP = 1.85 mm Straight Plug		-“XXXX” = Overall Length in millimeters -0100 (100 mm) 3.94" minimum

ALSO AVAILABLE

1.00 mm, 1.35 mm, 2.40 mm,
2.92 mm, SMPM, SMP, SMA = RF047-A
2.40 mm, 2.92 mm, SMPM, SMP, SMA = RF086

1.85 mm Board Connectors

185

Cable Mates:
RF047-A, RF086



185	GENDER	TYPE	PLATING	ORIENTATION	TERMINATION	OPTION	PACKAGING
	-J = Jack	-P = PCB Mount	-EP = 50 μ" (1.27 μm) Gold center contact, Passivated outer contact	-ST = Straight	-CM = Compression Mount Stripline -CMM = Compression Mount Microstrip	-1 = Without Screws (-CM & -CMM only) -2 = With Screws (-CM & -CMM only) -01 = .040" to .100" PCB thickness (-EL & -ELW only)	Leave blank for individually bagged. -B = Bulk packaged
					-EL = Edge Launch -ELW = Edge Launch Wide		

TERMINATION	A	B
-EL	(9.52) .375	(5.84) .230
-ELW	(12.70) .500	(9.53) .375

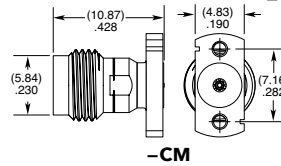
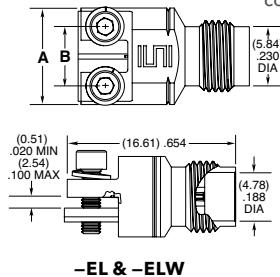

1.85 mm Cable Connectors

PRF18



CONNECTORS FOR INDUSTRY STANDARD CABLES	
PRF18-J-C-EP-085-BS	Harbour SS405
PRF18-P-C-EP-085-SS	Harbour SS405
PRF18-P-C-EE-085-SD	Harbour SS405
PRF18-J-C-EP-086-SS	Temp-Flex 1001935086
PRF18-J-C-EP-047A-SS	Temp-Flex 1000671047
PRF18-P-C-EP-047A-SS	Temp-Flex 1000671047
PRF18-J-C-EP-047D-SS	.047 Semi-Rigid
PRF18-P-C-EP-047D-SS	.047 Semi-Rigid
PRF18-P-C-EE-047D-SD	.047 Semi-Rigid
PRF18-P-C-EE-047H-SD	EZ-47-LA Semi-Rigid
PRF18-P-C-EP-070-SD	EZ-70-LA Semi-Rigid
PRF18-J-C-EE-405-SD	RG 405 Semi-Rigid
PRF18-P-C-EE-405-SD	RG 405 Semi-Rigid
PRF18-P-C-EP-086E-SS	Dynawave DF165

For a complete list of 1.85 mm cable connectors, visit www.samtec.com?PRF18

INTERFACE STANDARD

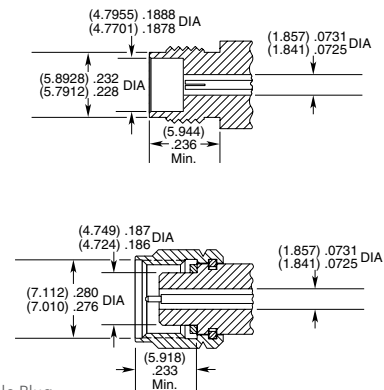

P-C = Cable Plug
J-C = Cable Jack
EE = Plating (50 μ" gold center contact, & outer contact)
EP = Plating (50 μ" gold center contact, passivated outer contact)
SS = Straight, Solder Clamp
SD = Straight, Direct Solder
BS = Bulkhead, Solder Clamp

2.40 mm TO 50 GHz

2.40 mm Cable Assemblies

RF047-A, RF085, RF086, RF23C



VSWR

RF047-A: 1.35 max.
RF086: 1.40 max.
RF085: 1.40 max.
RF23C: 1.40 max.

SERIES

RF047-A

= (1.2 mm) .047" overshield DIA 29 AWG millimeter wave cable

RF086

= (2.18 mm) .086" overshield DIA 23 AWG millimeter wave cable

RF085

= (2.16 mm) .085" overshield DIA 24 AWG millimeter wave cable

RF23C

= MWC-2350CU-01 millimeter wave cable with copper foil shield

END 1 CONNECTOR

-24SJ

= 2.40 mm Straight Jack

-24SP

= 2.40 mm Straight Plug

END 2 CONNECTOR

OVERALL LENGTH

- "XXXX"
= Overall Length in millimeters

-0100 (100 mm)
3.94" minimum

ALSO AVAILABLE

1.00 mm, 1.35 mm, 1.85 mm,
2.92 mm, SMPM, SMP, SMA = RF047-A

1.85 mm, 2.92 mm, SMPM, SMP, SMA = RF086

2.92 mm = RF085

2.92 mm, SMPM, SMP, SMA = RF23C

2.40 mm Board Connectors

240

Cable Mates:

RF047-A, RF086, RF085, RF23C



240 - GENDER - TYPE - PLATING - ORIENTATION - TERMINATION - OPTION - PACKAGING

-J
= Jack

-P
= PCB Mount

-EP
= 50 μ" (1.27 μm)
Gold center contact,
Passivated outer contact

-ST
= Straight

-CM
= Compression Mount Stripline

-CMM
= Compression Mount Microstrip

-EL
= Edge Launch

-ELW
= Edge Launch Wide

-1
= Without Screws
(-CM & -CMM only)

-2
= With Screws
(-CM & -CMM only)

-01
= .040" to .100" PCB thickness
(-EL & -ELW only)

Leave blank for individually bagged

-B
= Bulk packaged

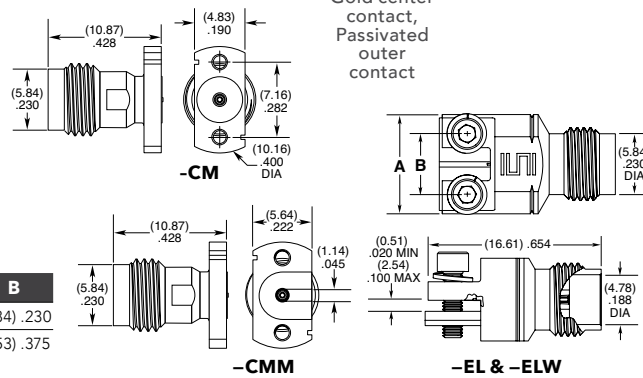

TERMINATION	A	B
-EL	(9.52) .375	(5.84) .230
-ELW	(12.70) .500	(9.53) .375

2.40 mm Cable Connectors

PRF24



CONNECTORS FOR INDUSTRY STANDARD CABLES

PRF24-J-C-EP-085-SS	Harbour SS405
PRF24-J-C-EP-405-BS	RG 405
PRF24-P-C-EE-085-SD	Harbour SS405
PRF24-P-C-EP-120A-SS	Semflex HP120
PRF24-J-C-EP-160-SS	Semflex HP160
PRF24-P-C-EP-160-SS	Semflex HP160
PRF24-J-C-EP-140B-SS	IW 1401
PRF24-P-C-EP-140B-SS	IW 1401
PRF24-J-C-EP-150B-SS	IW 1501
PRF24-J-C-EP-150-SS	Dynawave DF150
PRR24-J-C-EP-086-SS	Temp-Flex 1001935086
PRF24-P-C-EP-086-SS	Temp-Flex 1001935086

For a complete list of 2.40 mm cable connectors, visit www.samtec.com?PRF24

P-C = Cable Plug

J-C = Cable Jack

EE = Plating (50 μ" gold center contact & outer contact)

EP = Plating (50 μ" gold center contact, passivated outer contact)

SS = Straight, Solder Clamp

SD = Straight, Direct Solder

BS = Bulkhead, Solder Clamp

INTERFACE STANDARD

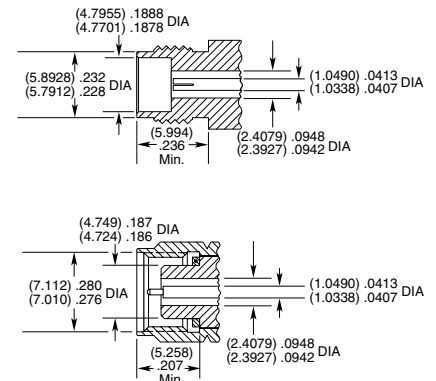

2.92 mm TO 40 GHz

2.92 mm Cable Assemblies

RF047-A, RF086, RF085, RF23C



VSWR

RF047-A: 1.35 max.
RF086: 1.40 max.
RF085: 1.40 max.
RF23C: 1.40 max.

SERIES	END 1 CONNECTOR	END 2 CONNECTOR	OVERALL LENGTH
RF047-A = (1.2 mm) .047" overshield DIA 29 AWG millimeter wave cable	-92SJ = 2.92 mm Straight Jack		-“XXXX” = Overall Length in millimeters
RF086 = (2.18 mm) .086" overshield DIA 23 AWG millimeter wave cable	-92SP = 2.92 mm Straight Plug		-0100 (100 mm) 3.94" minimum
RF085 = (2.16 mm) .085" overshield DIA 24 AWG millimeter wave cable	ALSO AVAILABLE		
RF23C = MWC-2350CU-01 millimeter wave cable with copper foil shield	1.00 mm, 1.35 mm, 1.85 mm, 2.40 mm, SMPM, SMP, SMA = RF047-A		
	1.85 mm, 2.40 mm, SMPM, SMP, SMA = RF086		
	2.40 mm = RF085		
	2.40 mm, SMPM, SMP, SMA = RF23C		

2.92 mm Board Connectors

292

Cable Mates:
RF047-A, RF085,
RF086, RF23C



TERMINATION	A	B
-EL	(9.52) .375	(5.84) .230
-ELW	(12.70) .500	(9.53) .375

292	GENDER	TYPE	PLATING	ORIENTATION	TERMINATION	OPTION	PACKAGING
	-J = Jack	-P = PCB Mount	-EP = 50 μ" (1.27 μm) Gold center contact, Passivated outer contact	-ST = Straight	-CM = Compression Mount Stripline -CMM = Compression Mount Microstrip	-1 = Without Screws (-CM & -CMM only) -2 = With Screws (-CM & -CMM only)	Leave blank for individually bagged. -B = Bulk packaged
					-EL = Edge Launch -ELW = Edge Launch Wide	-01 = .040" to .100" PCB thickness (-EL & -ELW only)	

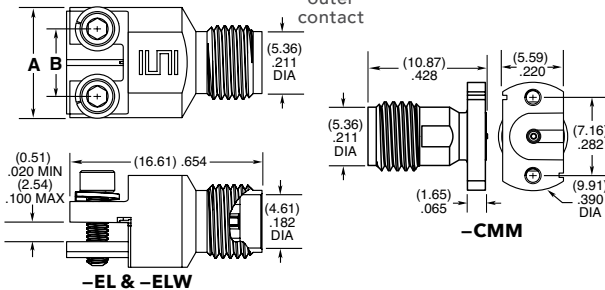

2.92 mm Cable Connectors

PRF92



CONNECTORS FOR INDUSTRY STANDARD CABLES	
PRF92-P-C-EE-405-SD	RG 405 Semi-Rigid
PRF92-P-C-EE-085A-SD	.085 Semi-Rigid
PRF92-P-C-EP-160-SS	Semflex HP160
PRF92-P-C-EP-150B-SS	IW 1501
PRF92-P-C-EP-142-SS	Harbour LL142
PRF92-J-C-EP-085-SS	Harbour SS405
PRF92-J-C-EP-085-BS	Harbour SS405
PRF92-P-C-EP-085-SS	Harbour SS405
PRF92-P-C-EE-402-SD	RG 402
PRF92-P-C-EP-190-SS	Semflex HP190
PRF92-J-C-EP-160-SS	Semflex HP160
PRF92-P-C-EP-120A-SS	Semflex HP120
PRF92-P-C-EP-140-SS	Dynawave DF140
PRF92-P-C-EP-047D-SS	.047 Semi-Rigid
PRF92-J-C-EP-047D-SS	.047 Semi-Rigid
PRF92-P-C-EP-150-SS	Dynawave DF150
PRF92-P-C-EE-118-SD	Haverhill HC35004
PRF92-J-C-EP-402-SS	RG 402
PRF92-J-C-EP-047D-4S	.047 Semi-Rigid
PRF92-P-C-EP-086-SS	Temp-Flex 1001935086
PRF92-P-C-EP-200-SS	Times Max Gain 200

For a complete list of 2.92 mm cable connectors, visit www.samtec.com?PRF92

INTERFACE STANDARD

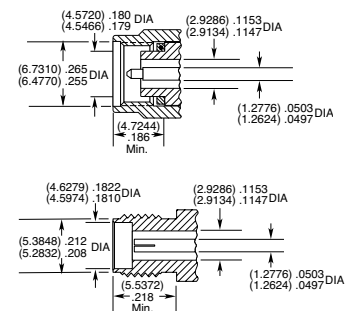

P-C = Cable Plug
J-C = Cable Jack
EE = Plating (50 μ" Gold center contact & outer contact)
EP = Plating (50 μ" Gold center contact, passivated outer contact)
SS = Straight, Solder Clamp
SD = Straight, Direct Solder
BS = Bulkhead, Solder Clamp
4S = 4-hole flange, Solder Clamp

3.50 mm TO 34 GHz

3.50 mm Cable Assemblies RF23S



VSWR

RF23S: 1.30 max

SERIES

RF23S
= MWC-2350-01 microwave cable with 23 AWG solid FEP Dielectric

END 1 CONNECTOR

-35SJP
= 3.50 mm Straight Jack
-35SPP
= 3.50 mm Straight Plug

END 2 CONNECTOR

OVERALL LENGTH

-"XXXX"
= Overall Length in millimeters
-0100 (100 mm) 3.94" min.

3.50 mm Cable Connectors PRF35



CONNECTORS FOR INDUSTRY STANDARD CABLES

PRF35-P-C-EP-405-SS	RG 405, Semi-Rigid
PRF35-J-C-EP-402-SS	RG 402, .141, Semi-Rigid
PRF35-J-C-EP-402-BS	RG 402, .141, Semi-Rigid
PRF35-P-C-EP-402-SS	RG 402, .141, Semi-Rigid
PRF35-P-C-EP-120A-SS	Semflex HP120
PRF35-J-C-EP-160-SS	Semflex HP160
PRF35-P-C-EP-160-SS	Semflex HP160
PRF35-P-C-EP-210A-SS	Micro-Coax UFA210A

For a complete list of 3.50 mm cable connectors, visit www.samtec.com?PRF35

P-C = Cable Plug

J-C = Cable Jack

EP = Plating (50 μ" Gold center contact, passivated outer contact)

SS = Straight, Solder Clamp

BS = Bulkhead, Solder Clamp

INTERFACE STANDARD

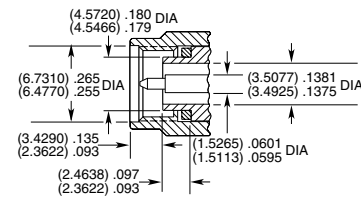
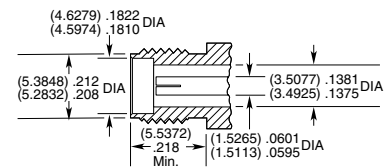

SSMA TO 34 GHz

SSMA Cable Connectors PRFS1



CONNECTORS FOR INDUSTRY STANDARD CABLES

PRFS1-J-C-EE-405-BD	RG 405, Semi-Rigid
PRFS1-P-C-EE-405-SD	RG 405, Semi-Rigid
PRFS1-P-C-EP-141A-SS	Harbour SS402

For a complete list of SSMA cable connectors, visit www.samtec.com?PRFS1

P-C = Cable Plug

J-C = Cable Jack

EE = Plating (50 μ" Gold center contact & outer contact)

EP = Plating (50 μ" Gold center contact, passivated outer contact)

SS = Straight, Solder Clamp

SD = Straight, Direct Solder

BD = Bulkhead, Direct Solder

INTERFACE STANDARD

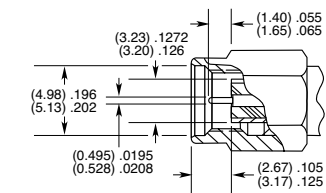
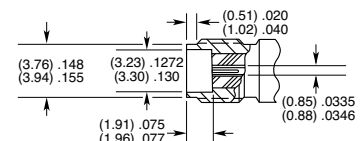

SMA TO 26.5 GHz

SMA Cable Assemblies

RF047-A, RF086, RF23C, RF25S, RF402, RF405, RF180, RF280

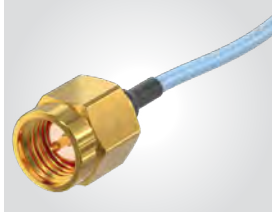

VSWR

RF047-A: 1.30 max.
RF086: 1.30 max.
RF23C: 1.30 max.
RF180: 1.35 max.
RF280: 1.35 max.

Additional connector options available. Contact RFGroup@samtec.com

SERIES	END 1 CONNECTOR	END 2 CONNECTOR	OVERALL LENGTH
RF047-A = (1.2 mm) .047" overshield DIA 29 AWG millimeter wave cable	-01SP1* = SMA Straight Plug		-“XXXX” = Overall Length in millimeters
RF086 = (2.18 mm) .086" overshield DIA 23 AWG millimeter wave cable	-01RP1* = SMA Right-angle Plug (RF047-A, RF086, RF23C & RF25S not available)		-0100 (100 mm) 3.94" minimum (RF047-A, RF086, RF23C, RF25S, RF402, & RF405)
RF23C = MCW-2350CU-01 millimeter wave cable with copper foil shield	-01BJ1* = SMA Bulkhead Jack (RF402 & RF405 not available)		-0152 (152 mm) 5.984" minimum (RF180)
RF25S = MWC-2550-01 microwave cable with 25 AWG solid FEP dielectric	-01SB = Straight Bulkhead Jack, Sealed (RF047-A, RF086 & RF23C only)		-0200 (200 mm) 7.87" minimum (RF280)
RF402 = RG 402 (.141") 19 AWG semi-flexible microwave cable	*Remove last "1" from end connector when specifying RF047-A, RF086, RF23C, RF180 & RF280.		

ALSO AVAILABLE

1.00 mm, 1.35 mm, 1.85 mm, 2.40 mm, 2.92 mm, SMPM, SMP = RF047-A

1.85 mm, 2.40 mm, 2.92 mm, SMPM, SMP = RF086

2.40 mm, 2.92 mm, SMPM, SMP = RF23C

SMP = RF25S, RF405

TNCA, N Type = RF180

TNCA, N Type = RF280

SMA Board Connectors

SMA-TH, SMA-SM, SMA-MT, SMA-EM

Cable Mates:

RF047-A, RF086, RF23C, RF25S, RF402, RF405, RF180, RF280



SMA	GENDER	TYPE	PLATING	ORIENTATION	TERMINATION
	-J = Jack	-P = PCB Mount	-H = 30 μ" (0.76 μm) Gold center contact, 3 μ" (0.08 μm) Gold outer contact	-ST = Straight	-TH1 = Through-hole
			-GF = 10 μ" (0.25 μm) Gold center contact, 3 μ" (0.08 μm) Gold outer contact (-SM1 only)	-RA = Right-angle	-SM1 = Surface Mount (-GF-RA only)
					-EM1 = Edge Mount (-ST only)
					-EM3 = Drop-in Edge Mount (-ST only)
					-MT1 = Mixed Technology (-ST only)

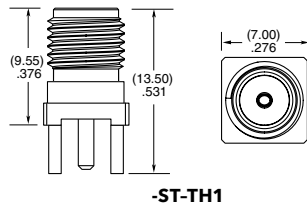

SMA Cable Connectors

PRF01



CONNECTORS FOR INDUSTRY STANDARD CABLES

PRF01-P-C-EP-120C-SS	Harbour LL120
PRF01-J-C-EP-142-SS	Harbour LL142
PRF01-P-C-EP-142-SS	Harbour LL142
PRF01-P-C-EP-142-RS	Harbour LL142
PRF01-P-C-EP-142A-SS	Harbour SB142
PRF01-P-C-EP-335-SS	Harbour LL335
PRF01-P-C-EP-335A-SS	Harbour LL335i
PRF01-P-C-EP-190-SS	Semflex HP190
PRF01-P-C-EP-190-RS	Semflex HP190
PRF01-P-C-EP-305-SS	Semflex HP305
PRF01-P-C-EP-290-SS	Semflex LA290

For a complete list of SMA cable connectors, visit www.samtec.com?PRF01

INTERFACE STANDARD

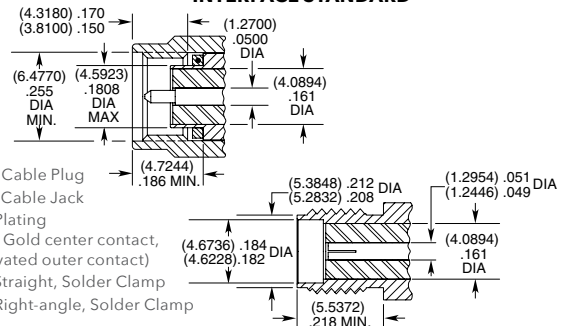

P-C = Cable Plug
 J-C = Cable Jack

EP = Plating

(50 μ" Gold center contact, passivated outer contact)

SS = Straight, Solder Clamp

RS = Right-angle, Solder Clamp

SMPM TO 65 GHZ

SMPM Ganged Cable: GC47, GC86

Mates With: GPPC

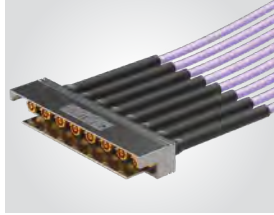

SERIES	NO. OF ROWS	NO. OF POSITIONS	OPTION	ASSEMBLY LENGTH
--------	-------------	------------------	--------	-----------------

GC47
= Ganged SMPM with (1.2 mm) .047" overshield DIA 29 AWG millimeter wave cable

GC86
= Ganged SMPM with (2.18 mm) .086" overshield DIA 23 AWG millimeter wave cable

-1
-02, -04, -06, -08, -10

Leave blank for no screws
-S
= Screw

-“XXXX”
= Assembly Length in millimeters
-0100 (100 mm)
3.94" minimum

OPTION	NO. OF POSITIONS	A	B	C
BLANK	-02	(8.89) .350	(3.56) .140	N/A
	-04	(16.00) .630	(10.67) .420	N/A
	-06	(23.11) .910	(17.78) .700	N/A
	-08	(30.23) 1.190	(24.89) .800	N/A
	-10	(37.34) 1.470	(32.00) 1.260	N/A
-S	-02	(17.53) .690	(3.56) .140	(13.59) .535
	-04	(24.64) .970	(10.67) .420	(20.70) .815
	-06	(31.75) 1.250	(17.78) .700	(27.81) 1.095
	-08	(38.86) 1.530	(24.89) .980	(34.93) 1.375
	-10	(45.97) 1.810	(32.00) 1.260	(42.04) 1.655

ALSO AVAILABLE

Other RF options for end 2
Contact RFGroup@samtec.com

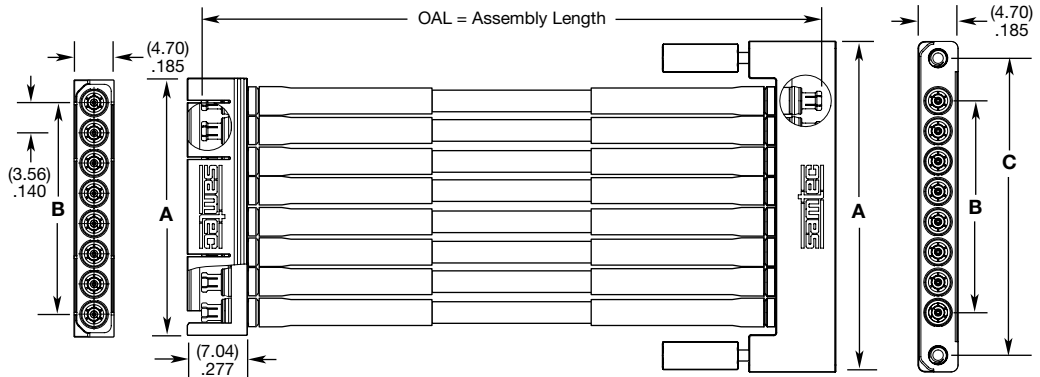

GC47-1-08-XXXX SHOWN

GC47-1-08-S-XXXX SHOWN

Notes:
Cable lengths longer than 1000 mm (39.37") are not supported with S.I. test data.

Some sizes, styles and options are non-standard, non-returnable.

SMPM Ganged Block: GPPB

Mates With: PRFIA

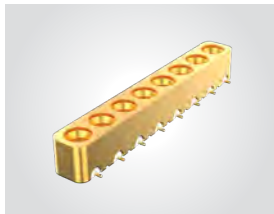

GPPB	GENDER	NO. OF ROWS	NO. OF POSITIONS	PLATING	ST	SM	CHANNEL PITCH
------	--------	-------------	------------------	---------	----	----	---------------

-PF
= Plug Full Detent

-PS
= Plug Smooth Bore

-PC
= Catcher's Mitt

-1
-02, -04, -06, -08, -10

-EG
= 50 μ" (1.27 μm) heavy Gold center contact, 10 μ" (0.25 μm) Gold outer body

-1N
= 3.56 mm (.140") Pitch

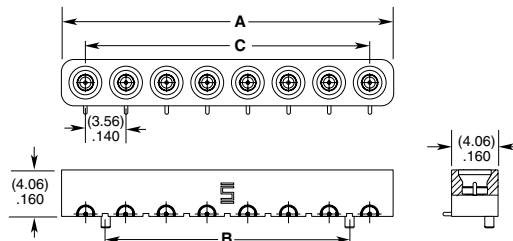

GPPB-PF-1-08-EG-ST-SM-1N SHOWN

NO. OF POSITIONS	A	B	C
-02	(7.62) .300	N/A	(3.56) .140
-04	(14.73) .580	(7.11) .280	(10.67) .420
-06	(21.84) .860	(14.22) .560	(17.78) .700
-08	(28.96) 1.14	(21.34) .840	(24.89) .980
-10	(36.07) 1.42	(28.45) 1.12	(32.00) 1.26

ALSO AVAILABLE

(8.33 mm) .328" Pitch
(5.08 mm) .200" Pitch
Edge Mount termination
Contact RFGroup@samtec.com

SMMP TO 65 GHz

GPPC	GENDER	1	NO. OF POSITIONS	PLATING	ORIENTATION	TERMINATION	OPTION	SCREW SIZE
	<p>-PF = Plug Full Detent</p> <p>-PS = Plug Smooth Bore</p> <p>-PC = Catcher's Mitt (-ST-SL & -RA-SM only)</p>		<p>-02, -04, -06, -08, -10 (Per Row)</p>	<p>-EG = 50 μ" (1.27 μm) heavy Gold center contact, 10 μ" (0.25 μm) extra Gold outer body (-EM-1N & -RA-SM only)</p> <p>-HG = 30 μ" (0.76 μm) Gold center contact, 10 μ" (0.25 μm) Gold outer body (-ST-SL only)</p>	<p>-ST = Straight</p> <p>-RA = Right-angle (-SM only)</p>	<p>-SM = Surface Mount (Right-angle only)</p> <p>-EM-1N = Edge Mount</p> <p>-SL = Stub Launch</p>	<p>Leave blank for no screws</p> <p>-S = Screw (not available with -SM)</p>	<p>-ST-SL only; Leave blank for non screw option</p> <p>-1 = (2.11 mm) .083" to (2.62 mm) .103" PCB thickness</p> <p>-2 = (1.24 mm) .049" to (1.75 mm) .069" PCB thickness</p> <p>-3 = (.38 mm) .015" to (.89 mm) .035" PCB Thickness</p>

SMMP

Ganged Block:

GPPC-ST-SL, GPPC-RA-SM, GPPC-EM

Mates With:

GC47, GC86

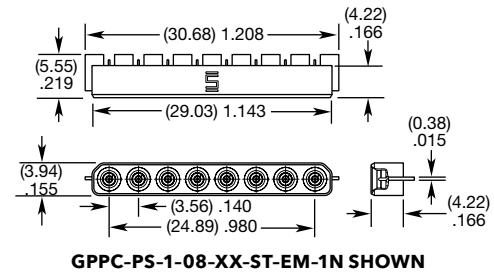
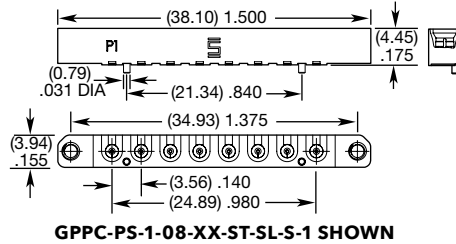
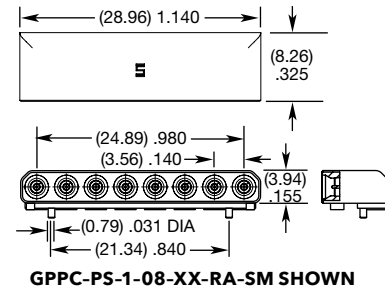
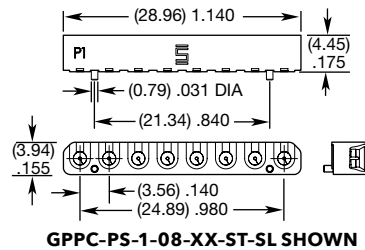

Notes:

Some sizes, styles and options are non-standard, non-returnable.

DUAL PORT SOLDERLESS COMPRESSION MOUNT

SMMP Ganged Block:

GPPC-CMM

Mates With:

GC47, GC86, PRFIA



GPPC	GENDER	1	2	PLATING	ORIENTATION	TERMINATION	PACKAGING
	<p>-PF = Plug Full Detent</p> <p>-PS = Plug Smooth Bore</p>			<p>-EP = 50 μ" (1.27 μm) heavy Gold center contact, Passivated outer body</p>	<p>-ST = Straight</p>	<p>-CMM = Compression Mount</p>	<p>Leave blank for individually bagged</p> <p>-B = Full Tray (Multiples of 100 required)</p>

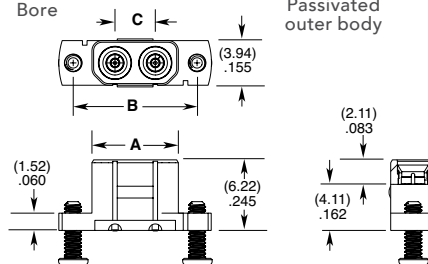

NO. OF POSITIONS	A	B	C
-02	(7.62) .300	(10.92) .430	(3.56) .140

SMPM TO 65 GHz

SMPM Cable Assemblies RF047-A, RF086, RF23C



VSWR

RF047-A: 1.40 max.
RF086: 1.40 max.
RF23C:
 1.20 max. (DC to 26.5 GHz)
 1.40 max. (26.5 GHz to 50 GHz)

SERIES

- RF047-A**
 = (1.2 mm) .047" overshield DIA
 29 AWG millimeter cable
- RF086**
 = (2.18 mm) .086" overshield DIA
 23 AWG millimeter cable
- RF23C**
 = MWC-2350CU-01 millimeter wave
 cable with copper foil shield

END 1 CONNECTOR

- MOSP**
 = SMPM Straight Plug, Full Detent
- MOSJ**
 = SMPM Straight Jack
- MORJ**
 = SMPM Right-angle Jack
 (RF047-A only)
- MOBJ**
 = SMPM Straight Bulkhead Jack
 (RF047-A only)

END 2 CONNECTOR

OVERALL LENGTH

-"XXXX"
 = Overall Length
 in millimeters

-0100 (100 mm)
 3.94" minimum

ALSO AVAILABLE

1.00 mm, 1.35 mm, 1.85 mm, 2.40 mm,
 2.92 mm, SMP, SMA = RF047-A

1.85 mm, 2.40 mm, 2.92 mm, SMP, SMA = RF086

2.40 mm, 2.92 mm, SMP, SMA = RF23C

SMPM Cable Connectors PRFM0



CONNECTORS FOR INDUSTRY STANDARD CABLES

PRFM0-J-C-EE-085-BD	Harbour SS405
PRFM0-J-C-EE-047A-BD	Temp-Flex 1000671047
PRFM0-J-C-HG-047A-SD	Temp-Flex 1000671047
PRFM0-J-C-EE-047A-RD	Temp-Flex 1000671047
PRFM0-P-C-HG-047A-SD	Temp-Flex 1000671047
PRFM0-J-C-EE-047B-SD	Temp-Flex 1001935047
PRFM0-J-C-EE-086-SD	Temp-Flex 1001935086
PRFM0-P-C-EE-086-SD	Temp-Flex 1001935086

For a complete list of SMPM cable connectors, visit www.samtec.com?PRFM0

P-C = Cable Plug

J-C = Cable Jack

EE = Plating (50 μ" Gold center contact & outer contact)

HG = Plating (30 μ" Gold center contact, 10 μ" Gold outer contact)

SD = Straight, Direct Solder

BD = Bulkhead, Direct Solder

RD = Right-angle, Direct Solder

INTERFACE STANDARD (CATCHER'S MITT)

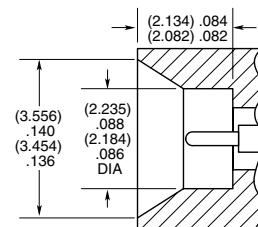

SMMP TO 65 GHz

SMMP Board Connectors

SMMP-SM, SMMP-TH, SMMP-RA, SMMP-MT, SMMP-EM

Cable Mates:

RF047-A, RF086, RF23C

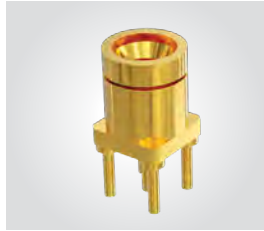

SMMP	GENDER	TYPE	PLATING	ORIENTATION	TERMINATION	OPTION
	-PF = Full Detent	-P = PCB Mount	-HG = 30 μ" (0.76 μm) Gold center contact, 10 μ" (0.25 μm) Gold outer contact (-ST only)	-ST = Straight	-EM = Drop-in Edge Mount (-ST only)	-1 = Standard
	-PS = Smooth Bore		-HF = 30 μ" (0.76 μm) Gold center contact, 3 μ" (0.08 μm) Gold outer contact (-RA only)	-RA = Right-angle (-TH required)	-TH = Through-hole	-2 = Reverse Mount (-EE and -SM only; see website for print)
	-PC = Catcher's Mitt (-ST-TH, -ST-MT & -ST-SM only)		-EG = 50 μ" (1.27 μm) Gold center contact, 10 μ" (0.25 μm) Gold outer body (-MT & -SM only)		-SM = Surface Mount (-ST only)	
			-EE = 50 μ" (1.27 μm) extra heavy Gold center contact and outer body (SM-2 only)		-MT = Mixed Technology (-ST only)	

-ST-TH-1	-RA-TH-1	-ST-EM-1	-ST-SM-1

SMMP THREADED TO 65 GHz

SMMPMT Board Connectors

SMMPMT-MT

Cable Mates:

RF047-A, RF086, RF23C

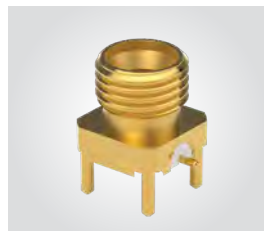

SMMPMT	GENDER	TYPE	PLATING	ORIENTATION	TERMINATION	OPTION
	-PF = Full Detent	-P = PCB Mount	-EG = 50 μ" (1.27 μm) Gold center contact, 10 μ" (0.25 μm) Gold outer body	-ST = Straight	-MT = Mixed Technology	-1 = Standard
	-PS = Smooth Bore					

SMMPMT-PF-P-EG-ST-MT-1	SMMPMT-PS-P-EG-ST-MT-1

SMP TO 40 GHz

SMP Cable Assemblies

RF047-A, RF086, RF23C, RF25S, RF405



VSWR

RF047-A: 1.50 max.
RF086: 1.50 max.
RF23C: 1.50 max.
RF25S: Contact Samtec
RF405: Contact Samtec

SERIES	END 1 CONNECTOR	END 2 CONNECTOR	OVERALL LENGTH
RF047-A = (1.2 mm) .047" overshield DIA 29 AWG millimeter wave cable	-00SJ = SMP Straight Jack (RF047-A, RF086 & RF23C only)		-“XXXX” = Overall Length in millimeters
RF086 = (2.18 mm) .086" overshield DIA 23 AWG millimeter wave cable	-00MJ = SMP Right-angle Jack (RF047-A, RF086 & RF23C only)		-0100 (100 mm) 3.94" minimum
RF23C = MWC-2350CU-01 millimeter wave cable with copper foil shield	-00BF = SMP Bulkhead Jack, Full Detent (RF086 & RF23C only)		
RF25S = MWC-2550-01 microwave cable with 25 AWG solid FEP dielectric	-00BL = SMP Bulkhead Jack, Limited Detent (RF086 & RF23C only)		
RF405 = RG 405 (.086") 24 AWG semi-flexible microwave cable	-00BS = SMP Bulkhead Jack, Smooth Bore (RF086 & RF23C only)		
	-00BC = SMP Bulkhead Jack, Catcher's Mitt (RF086 & RF23C only)		
	-00SJ7 = SMP Straight Jack (RF25S & RF405 only)		
	-00RJ7 = SMP Right-angle Jack (RF25S & RF405 only)		

ALSO AVAILABLE

1.00 mm, 1.35 mm, 1.85 mm, 2.40 mm, 2.92 mm, SMPM, SMA = RF047-A
 1.85 mm, 2.40 mm, 2.92 mm, SMPM, SMA = RF086
 2.40 mm, 2.92 mm, SMPM, SMA = RF23C
 SMA = RF25S
 SMA = RF405

SMP Cable Connectors

PRF00



CONNECTORS FOR INDUSTRY STANDARD CABLES	
PRF00-J-C-EE-047A-RD	Temp-Flex 1000671047
PRF00-J-C-EE-085A-SD	.086 Semi-Rigid
PRF00-PF-C-KK-047D-BD	.047 Semi-Rigid

For a complete list of SMP cable connectors, visit www.samtec.com?PRF00

J-C = Cable Jack

EE = Plating (50 μ" Gold center contact & outer contact)

KK = Plating (100 μ" Gold over Nickel center contact, passivated outer contact)

BD = Bulkhead, Direct Solder

SD = Straight, Direct Solder

RD = Right-angle, Direct Solder

INTERFACE STANDARD (FULL DETENT)

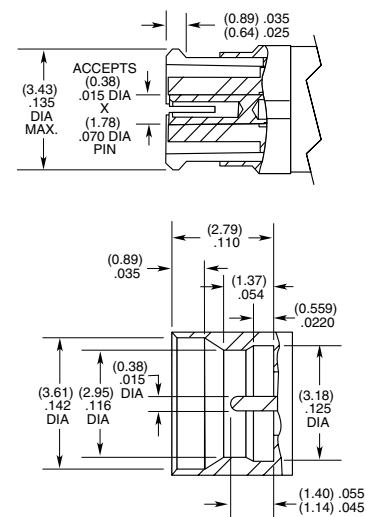

SMP TO 40 GHz

SMP Board Connectors

SMP-TH, SMP-EM,
SMP-MT, SMP-SM

Cable Mates:

RF047-A, RF086,
RF23C, RF405, RF25S

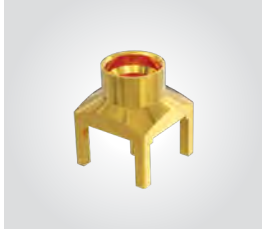

SMP	GENDER	TYPE	PLATING	ORIENTATION	TERMINATION
-----	--------	------	---------	-------------	-------------

-PF
= Plug, Full Detent

-PL
= Plug, Limited Detent

-PS
= Plug, Smooth Bore

-PC
= Plug, Catcher's Mitt

-P
= PCB Mount

-HG
= 30 μ" (0.76 μm)
Gold center contact,
10 μ" (0.25 μm)
Gold outer body

-ST
= Straight

-SM
= Surface Mount

-TH"X"
= Through-hole
(Specify "X"
from chart)

-MT"X"
= Mixed Technology
(Specify "X"
from chart)

-EM
= Edge Mount
(-PF, -PL & -PS only)

OPTION (X)	A (HEIGHT DIM.)	BOARD THICKNESS
1 (-MT only)	(5.88) .2315	(1.60 mm) .062" PCB
2 (-MT only)	(6.72) .2645	(2.36 mm) .093" PCB
3 (-TH only)	(5.88) .2315	(1.60 mm) .062" PCB
4 (-TH only)	(6.72) .2645	(2.36 mm) .093" PCB

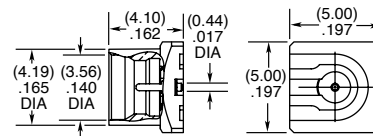

-SM

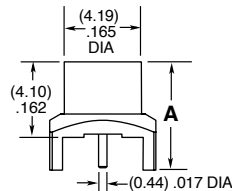

-TH(X)

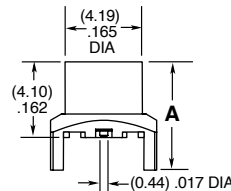

-MT(X)

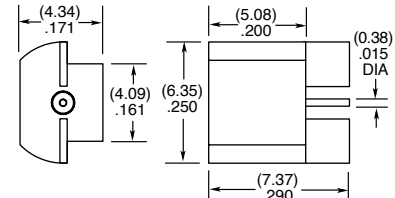

-EM

ALSO AVAILABLE

Low Frequency options.
Contact RFGroup@samtec.com

SMP Bullet Adaptor

SMP-B



SMP	J	TYPE	PLATING	ORIENTATION	BULLET LENGTH
-----	---	------	---------	-------------	---------------

-B
= Bullet Adaptor

-HG
= 30 μ" (0.76 μm)
Gold center contact,
10 μ" (0.25 μm)
Gold outer body

-ST
= Straight

-0625
= (6.25 mm) .246"

-0645
= (6.45 mm) .254"

-0725
= (7.25 mm) .285"

-0825
= (8.25 mm) .325"

-0925
(9.25 mm) .364"

-1325
(13.25 mm) .522"

-1450
= (14.50 mm) .571"

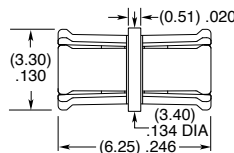

-0625

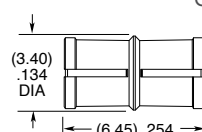

-0645

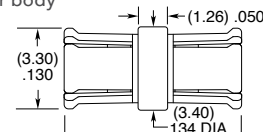

-0725

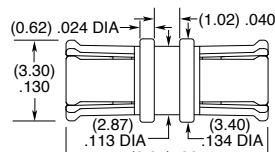

-0825

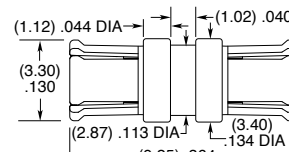

-0925

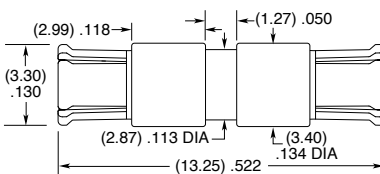

-1325

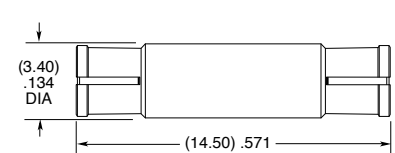

-1450

N TYPE TO 18 GHz

N Type Cable Assemblies

RF180, RF280



VSWR

RF 180:
1.35 max. (-06SP & -06BJ)
1.45 max. (-06RP)

RF 280:
1.35 max. (-06SP & -06BJ)
1.35 max. (DC to 14 GHz) (-06RP)
1.50 max. (14 GHz to 18 GHz)

SERIES	END 1 CONNECTOR	END 2 CONNECTOR	OVERALL LENGTH
RF180 = (4.52 mm) .178" overshield DIA, 16 AWG microwave cable	-06SP = N Type Straight Plug	-06SP = N Type Straight Plug	-"XXXX" = Overall length in millimeters
RF280 = (7 mm) .277" overshield DIA, 11 AWG microwave cable	-06RP = N Type Right-angle Plug	-06RP = N Type Right-angle Plug	-0152 (152 mm) 5.984" minimum (RF180)
	-06BJ = N Type Straight Bulkhead Jack	-06BJ = N Type Straight Bulkhead Jack	-0200 (200 mm) 7.87" minimum (RF280)

ALSO AVAILABLE

SMA, TNCA = RF180
SMA, TNCA = RF280

N Type Cable Connectors

PRF06



CONNECTORS FOR INDUSTRY STANDARD CABLES	
PRF06-P-C-EP-141A-SS	Harbour SS402
PRF06-J-C-EP-142-BS	Harbour LL142
PRF06-P-C-EP-142-SS	Harbour LL142
PRF06-P-C-EP-142-RS	Harbour LL142
PRF06-P-C-EP-142A-SS	Harbour SB142
PRF06-J-C-EP-335-BS	Harbour LL335
PRF06-P-C-EP-335-SS	Harbour LL335
PRF06-P-C-EP-335-RS	Harbour LL335
PRF06-P-C-EP-335A-SS	Harbour LL335i
PRF06-P-C-EP-335A-SS	Harbour LL335i
PRF06-P-C-EP-335A-RS	Harbour LL335i
PRF06-J-C-EP-160A-BS	Harbour LL160
PRF06-P-C-EP-160A-SS	Harbour LL160
PRF06-P-C-EP-160A-RS	Harbour LL160
PRF06-P-C-EP-120A-SS	Semflex HP120
PRF06-J-C-EP-190-BS	Semflex HP190
PRF06-P-C-EP-190-SS	Semflex HP190
PRF06-P-C-EP-190-RS	Semflex HP190
PRF06-J-C-EP-290-BS	Semflex LA290
PRF06-P-C-EP-290-SS	Semflex LA290
PRF06-P-C-EP-290-RS	Semflex LA290
PRF06-P-C-EP-305-SS	Semflex HP305
PRF06-J-C-EP-402-4S	RG 402, .141, semi-rigid
PRF06-P-C-EP-300A-SS	Times Max Gain 300
PRF06-P-C-EP-180B-SS	IW 1801
PRF06-P-C-EP-135-SS	Dynawave DF440W
PRF06-P-C-EP-270A-RS	Dynawave DF218
PRF06-P-C-EP-160B-SS	ATM CF-210
PRF06-P-C-EP 135B-SS	Lab-Flex 160S
PRF06-P-C-EP-284-SS	Micro-Coax UFB311A

For a complete list of N Type cable connectors, visit www.samtec.com?PRF06

INTERFACE STANDARD

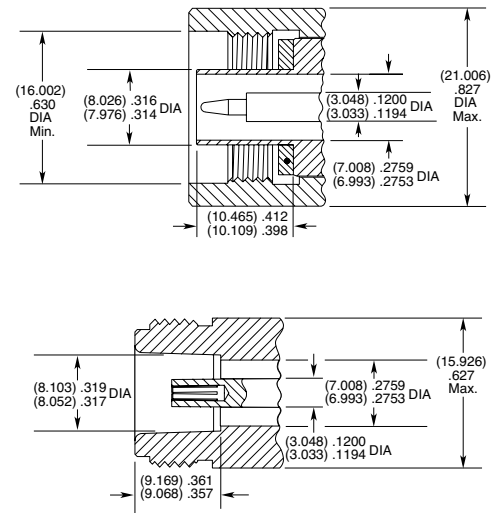

P-C = Cable Plug
J-C = Cable Jack
EP = Plating (50 μ" Gold center contact, passivated outer contact)
SS = Straight, Solder Clamp
RS = Right-angle, Solder Clamp
BS = Bulkhead, Solder Clamp
4S = 4-hole Flange, Solder Clamp

TNCA TO 18 GHz

TNCA Cable Assemblies

RF180, RF280

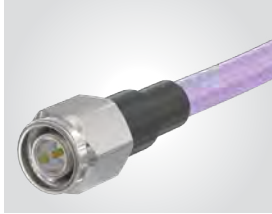

VSWR

RF180: 1.35 max. (-04SP & -04BJ)
1.45 max. (-04RP)
RF280: 1.35 max. (-04SP & -04BJ)

SERIES	END 1 CONNECTOR	END 2 CONNECTOR	OVERALL LENGTH
RF180 = (4.52 mm) .178" overshield DIA, 16 AWG microwave cable RF280 = (7 mm) .277" overshield DIA, 11 AWG microwave cable	-04SP = TNCA Straight Plug -04RP = TNCA Right-angle Plug (RF180 only) -04BJ = TNCA Straight Bulkhead Jack	-"XXXX" = Overall length in millimeters -0152 (152 mm) 5.984" minimum (RF180) -0200 (200 mm) 7.87" minimum (RF280)	

ALSO AVAILABLE

SMA, N Type = RF180
SMA, N Type = RF280

TNCA Cable Connectors

PRF04



CONNECTORS FOR INDUSTRY STANDARD CABLES	
PRF04-P-C-EP-142-RS	Harbour LL142
PRF04-J-C-EP-142-BS	Harbour LL142
PRF04-P-C-EP-142-SS	Harbour LL142
PRF04-P-C-EP-335-SS	Harbour LL335
PRF04-P-C-EP-290-SS	Semflex LA290
PRF04-J-C-EP-190-BS	Semflex HP190
PRF04-P-C-EP-190-RS	Semflex HP190
PRF04-P-C-EP-190-SS	Semflex HP190
PRF04-P-C-EP-335A-RS	Harbour LL335i
PRF04-J-C-EP-335A-BS	Harbour LL335i
PRF04-P-C-EP-300A-SS	Times Max Gain 300
PRF04-P-C-EP-200-SS	Times Max Gain 200
PRF04-P-C-EP-160A-SS	Harbour LL160
PRF04-J-C-EP-270A-BS	Dynawave DF218
PRF04-P-C-EP-135-SS	Dynawave DF440W
PRF04-P-C-EP-300A-SS	Times Max Gain 300
PRF04-J-C-EP-210A-BS	Micro-Coax UFA210A
PRF04-P-C-EP-210A-SS	Micro-Coax UFA210A
PRF04-P-C-EP-284-SS	Micro-Coax UFB311A
PRF04-J-C-EP-127-4S	Storm VSR150

For a complete list of TNCA cable connectors, visit www.samtec.com?PRF04

INTERFACE STANDARD

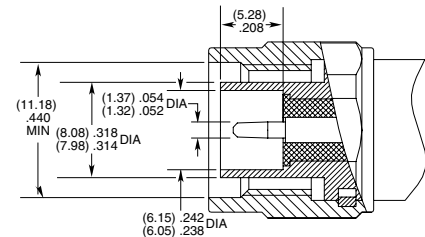
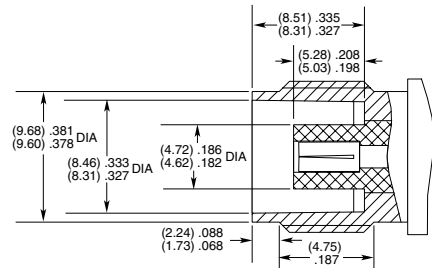

P-C = Cable Plug
J-C = Cable Jack
EP = Plating (50 μ" Gold center contact, passivated outer contact)
SS = Straight, Solder Clamp
RS = Right-angle, Solder Clamp
BS = Bulkhead, Solder Clamp
4S = 4-Hole Flange

IN-SERIES PRECISION RF ADAPTORS

1.85 mm, 2.40 mm, 2.92 mm In-Series Adaptors
PRFIA



VSWR

-185: 1.30 max.
-240: 1.20 max.
-292: 1.15 max.

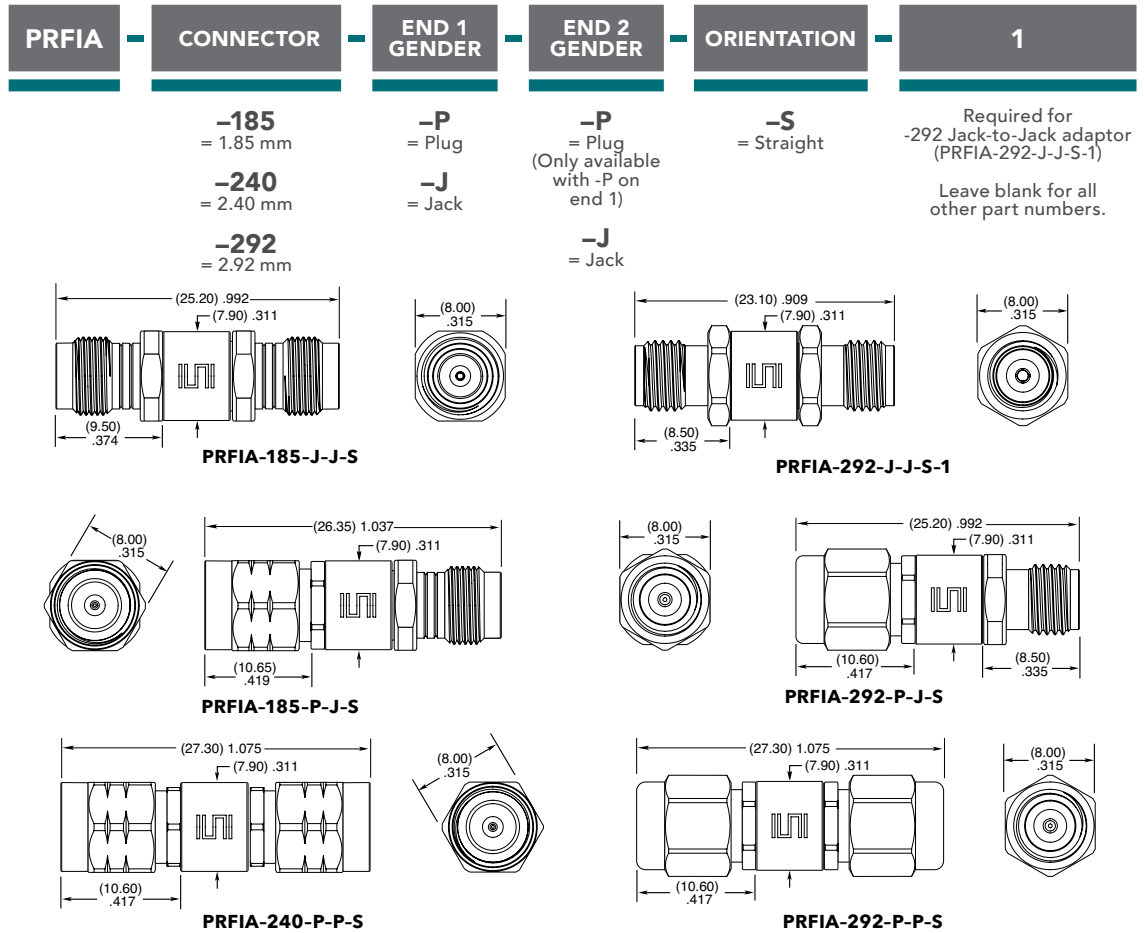

SMPM In-Series Adaptor:
PRFIA

Mates With:
SMPM, GPPB, GPPC



VSWR

1.15 max. (DC to 26.5 GHz)
1.35 max. (26.5 GHz to 40 GHz)
1.50 max. (40 GHz to 65 GHz)

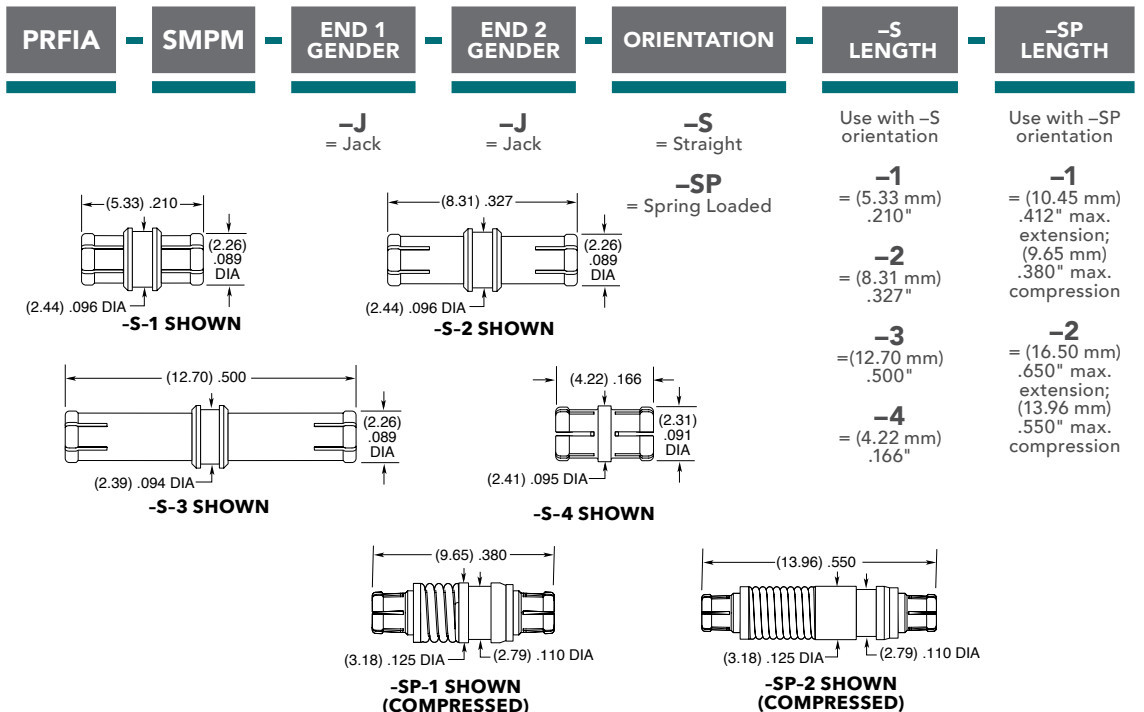

BETWEEN-SERIES PRECISION RF ADAPTORS

1.00 mm to 1.85 mm Adaptors

PRFBA



PRFBA	CONNECTOR	END 1 GENDER	CONNECTOR	END 2 GENDER	ORIENTATION
-------	-----------	--------------	-----------	--------------	-------------

-100
= 1.00 mm

-P
= Plug
-J
= Jack

-185
= 1.85 mm

-P
= Plug
-J
= Jack

-S
= Straight

VSWR

1.12 max. (DC to 26.5 GHz)
1.25 max. (26.5 GHz to 40 GHz)
1.30 max. (40 GHz to 50 GHz)
1.35 max. (50 GHz to 67 GHz)

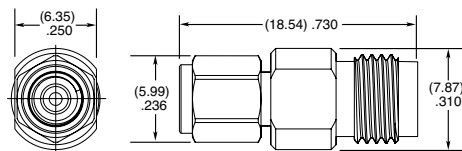

PRFBA-100-P-185-J-S

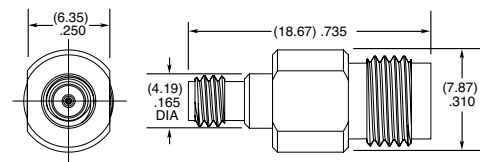

PRFBA-100-J-185-J-S

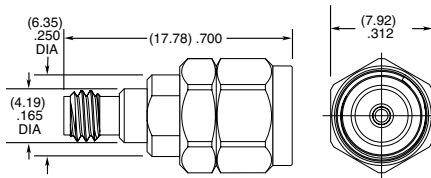

PRFBA-100-J-185-P-S

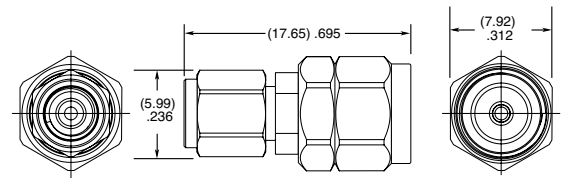

PRFBA-100-P-185-P-S

2.92 mm to SMPM Adaptors

PRFBA



PRFBA	CONNECTOR	END 1 GENDER	CONNECTOR	END 2 GENDER	ORIENTATION	1
-------	-----------	--------------	-----------	--------------	-------------	---

-292
= 2.92 mm

-P
= Plug
-J
= Jack

-SMPM

-J
= Jack
-PF
= Plug Full Detent

-S
= Straight

Required for Jack-to-Jack adaptor (PRFBA-292-J-SMPM-J-S-1)

Leave blank for all other part numbers.

VSWR

1.30 max. (DC to 40 GHz)

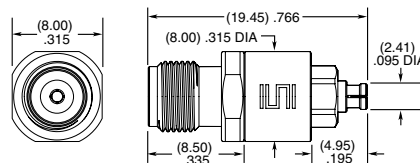

PRFBA-292-J-SMPM-J-S-1

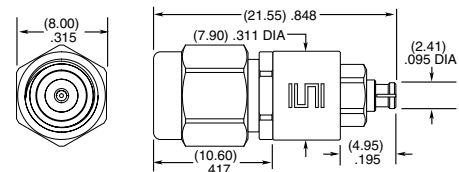

PRFBA-292-P-SMPM-J-S

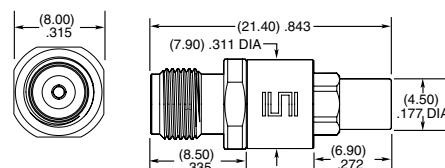

PRFBA-292-J-SMPM-PF-S

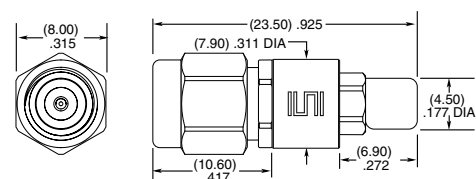

PRFBA-292-P-SMPM-PF-S

TEST & MEASUREMENT

OPTIMIZED PERFORMANCE TO 90 GHZ

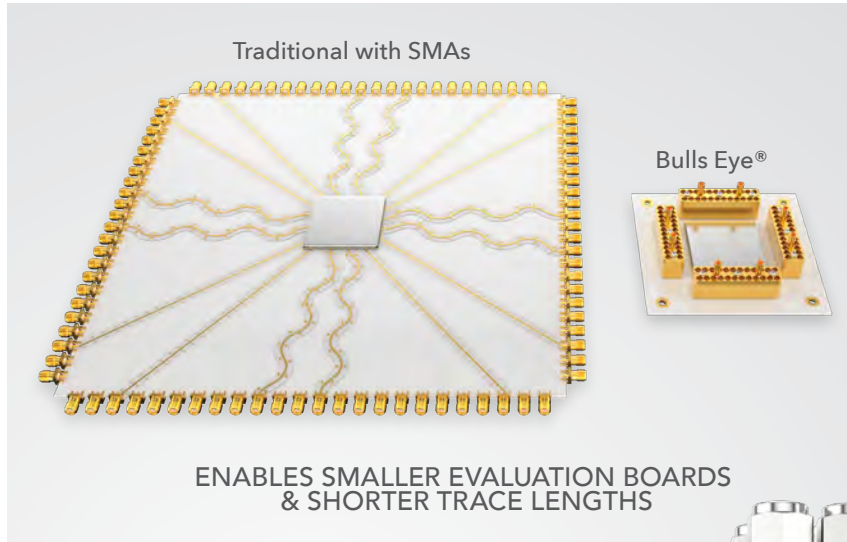

DC TO	PAM 4
90 GHz	224 Gbps

Bulls Eye® High-Performance Test

The Bulls Eye® high-performance test assembly features a high-density, space-saving design that enables smaller evaluation boards and shorter trace lengths in test and measurement applications to 90 GHz.

- Compression mounts to the board for placement directly adjacent to the SerDes being characterized
- Solderless design improves cost and is easy to use within a lab setting
- Microwave cable assemblies: .047" and .086", and Nitrowave™ phase and amplitude stable in distinctive Samtec orange
- End 2 connection to instrumentation: 1.00 mm, 1.35 mm, 1.85 mm, 2.40 mm or 2.92 mm
- High-density, space-saving design
- Single row or double row
- Complete list of applications: SerDes characterization, clock/data recovery (CDR), mmWave radar, automated test equipment, FR2 5G networks

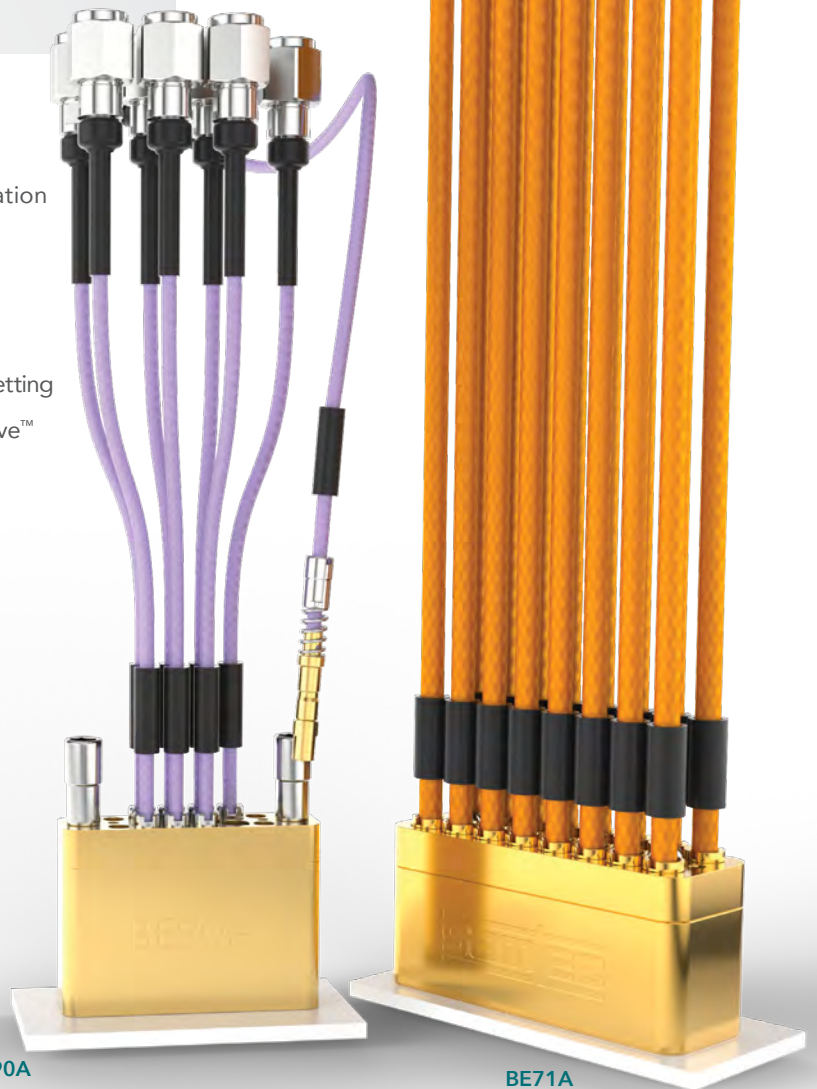

PRODUCT FAMILY CROSS REFERENCE GUIDE

ASSEMBLY	90 GHz	71 GHz	70 GHz	50 GHz	40 GHz
Block Bottom View					
SerDes Characterization	224 Gbps PAM4	224 Gbps PAM4	112 Gbps PAM4	56 Gbps PAM4	
End 2 Connector	1.00 mm 1.35 mm	1.85 mm	1.85 mm	2.40 mm	2.92 mm
Samtec Series	BE90A	BE71A	BE70A	BE40A	
Cable Type	.047	High-Performance Nitrowave™ LL071	.086	MWC-2350CU-01	
Cable Management	Yes				
PCB Transition	Microstrip/CPW or Stripline				
Bulls Eye® Connector Design	Spring-Loaded Contact; 360° Grounding	Robust Pogo-Pin; 360° Grounding	Spring-Loaded Contact; 360° Grounding	Pogo-Pin for Signal & Ground	
No. of Rows	Single or Double			Double	
No. of Positions	1x: 2, 4, 8, 12 2x: 4, 8, 12, 16	1x: 2, 4, 8, 12 2x: 3, 4, 6, 8, 10, 12, 14, 16		2x: 3, 4, 6, 8, 10, 12, 14, 16	
Impedance	50 Ω				
FPGA Development Kit	-			Xilinx® Zynq® UltraScale+™ RFSoc ZCU1275	
SI Evaluation Kit	-	70 GHz: REF-213864-01		50 GHz: REF-213497-01	

71 GHz ASSEMBLIES WITH NITROWAVE™ CABLE

BE71A	TRANSMISSION TYPE	END 2	PHASE MATCH (RANGE)	PHASE MATCH (LOCATION)	2	POSITIONS PER ROW	OVERALL LENGTH
	-S = Stripline -M = Microstrip	-18SP = 1.85 mm Straight Plug -18BJ = 1.85 mm Straight Jack	-H = 0.5 Pico-second -1 = 1.0 Pico-second -2 = 2.0 Pico-seconds -5 = 5.0 Pico-seconds -N = No Phase Matching	-R = In-row -A = Across-row		-03, -04, -06, -08, -10, -12, -14, -16	-“XXXX” = Overall length in millimeters -0152 (152 mm) 5.984” minimum
DC TO	PAM 4						
71 GHz	224 Gbps						

BE71A
End 2 Connectors:
1.85 mm (71 GHz)
2.92 mm (40 GHz)

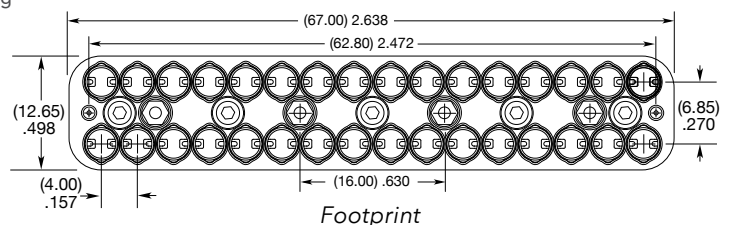

16 POSITIONS PER ROW SHOWN

90 GHz ASSEMBLIES

BE90A	TRANSMISSION TYPE	END 2	PHASE MATCHING	ROW OPTION	POSITIONS PER ROW	OVERALL LENGTH
	-S = Stripline -M = Microstrip	-10BJ = 1.00 mm Straight Jack -10SP = 1.00 mm Straight Plug -13BJ = 1.35 mm Straight Jack -13SP = 1.35 mm Straight Plug	-1 = 1.0 Pico-second -2 = 2.0 Pico-seconds -5 = 5.0 Pico-seconds -N = No Phase Matching	-1 = Single Row (-02, -04, -08 & -12 positions only) -2 = Double Row (-04, -08, -12 & -16 positions only)	-02, -04, -08, -12, -16	"XXXX" = Overall length in millimeters -0152 (152 mm) 5.984" minimum (Single Row) -0100 (100 mm) 3.937" minimum (Double Row)

BE90A
End 2 Connectors:
1.00 mm, 1.35 mm

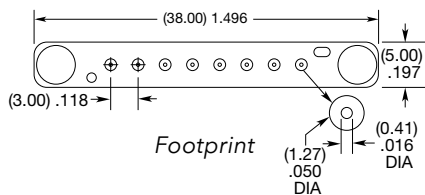

8 POSITIONS PER ROW -1 SHOWN

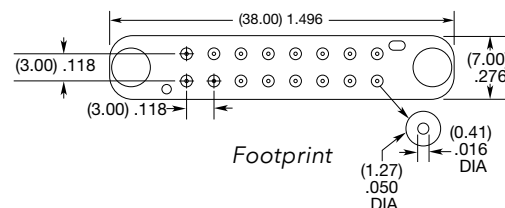

8 POSITIONS PER ROW -2 SHOWN

BE90A, 2 X 4 FOOTPRINT

Measured performance of a BE90A, 2x4-S (stripline) block, 100 mm low-loss microwave cable and 1.00 mm end 2 connectors. Results include BE90A cable assembly, the launch region, and 1.75 mm of trace. All other effects have been removed by de-embedding

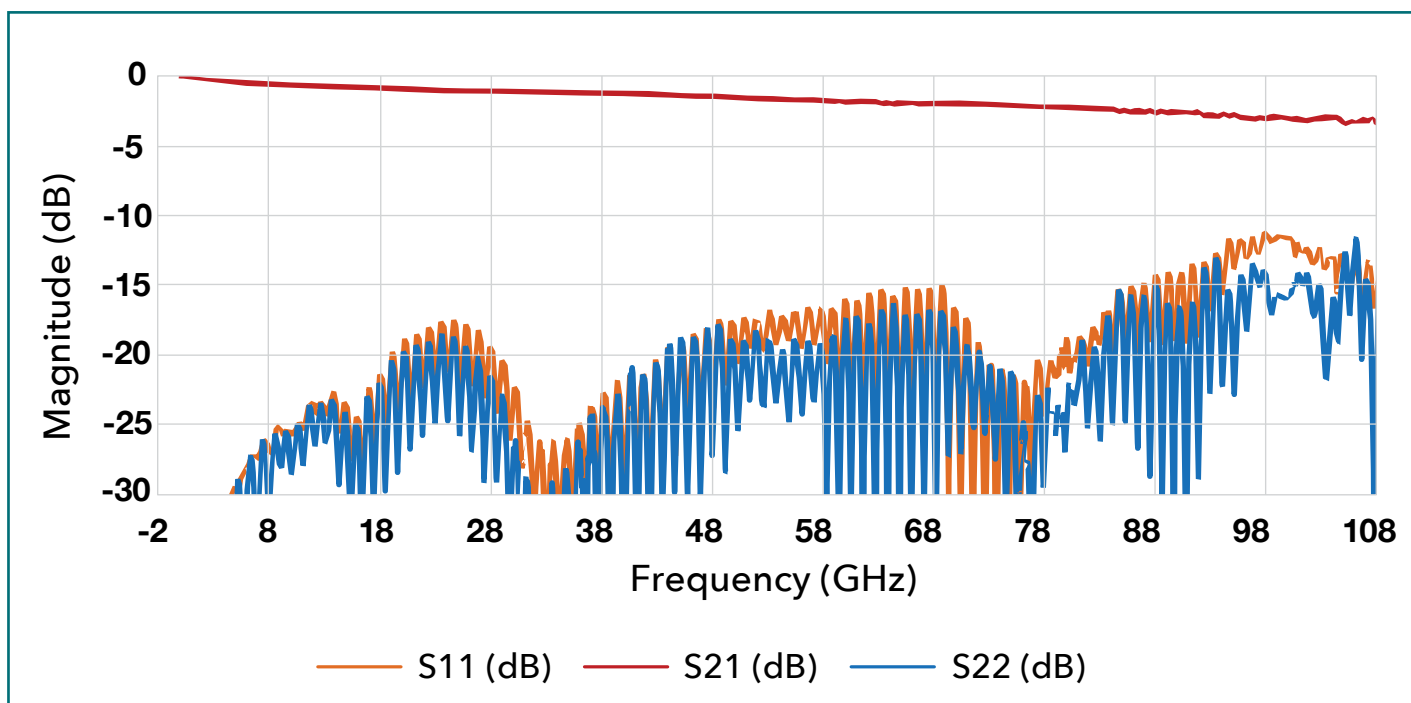

70 GHz ASSEMBLIES

BE70A	TRANSMISSION TYPE	END 2	PHASE MATCHING	ROW OPTION	POSITIONS PER ROW	OVERALL LENGTH
	-S = Stripline -M = Microstrip	-18SJ = 1.85 mm Straight Jack -18SP = 1.85 mm Straight Plug	-2 = 2.0 Pico-seconds -5 = 5.0 Pico-seconds -N = No Phase Matching	-1 = Single Row (-02, -04, -08 & -12 positions only) -2 = Double Row (-03 through -16 positions only)	-02, -03, -04, -06, -08, -10, -12, -14, -16	-“XXXX” = Overall length in millimeters -0152 (152 mm) 5.984" minimum

DC TO **70** GHz
PAM 4 **112** Gbps

BE70A
End 2 Connectors:
1.85 mm (70 GHz)

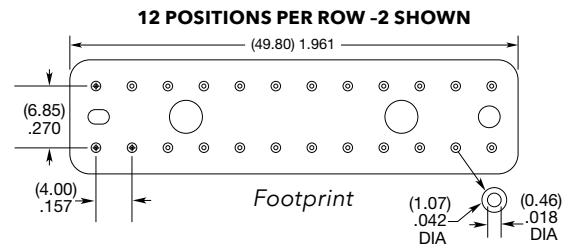
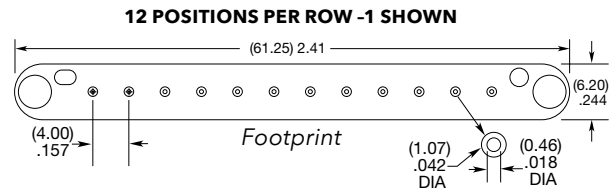

50 GHz & 40 GHz ASSEMBLIES

BE40A	TRANSMISSION TYPE	END 2	PHASE MATCHING	2	POSITIONS PER ROW	OVERALL LENGTH
	-S = Stripline -M = Microstrip	-92SJ = 40 GHz, 2.92 mm Straight Jack -24SJ = 50 GHz, 2.40 mm Straight Jack -92SP = 40 GHz, 2.92 mm Straight Plug -24SP = 50 GHz, 2.40 mm Straight Plug	-2 = 2.0 Pico-seconds -5 = 5.0 Pico-seconds -N = No Phase Matching		-03, -04, -06, -08, -10, -12, -14, -16	-“XXXX” = Overall length in millimeters -0152 (152 mm) 5.984" minimum

DC TO **50** GHz
PAM 4 **56** Gbps

BE40A
End 2 Connectors:
2.40 mm (50 GHz)
2.92 mm (40 GHz)

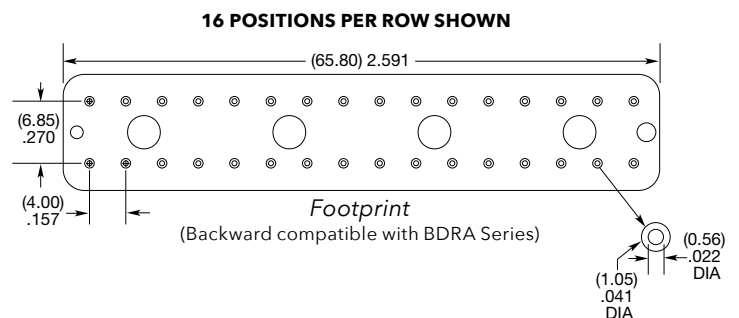

RUGGED, BLIND MATE MODULES & CONTACTS

MODULAR, CONFIGURABLE SOLUTIONS

Samtec offers a flexible blind-mate module solution for RF and optical that is ideal for rugged applications. Choose from numerous options to create a customized module that meets the needs of your application. These pages highlight a few of the many options available; contact the RFGroup@samtec.com for more options or information.

STEPS FOR BUILDING A SOLUTION



1. Choose Block



2. Choose Contact

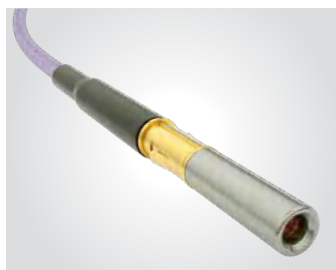

3. Choose Cable Option
(RF/Optical)



4. Finished Solution

BLOCK OPTIONS

VBM

GENDER

APERTURE FILL

CARD THICKNESS



-M
= Male
(For GPCC-P pin option only)

-F
= Female
(For GPCC-S socket option only)

-A
= 6x Size 20, 1x MT Ferrule

-01
= (1.60 mm) .062" thick card

-B
= 2x MT Ferrule

-02
= (2.36 mm) .093" thick card

-C
= 6x Size 16, 1x MT Ferrule

-D
= 8x Size 16

-E
= 10x Size 20

PRELIMINARY

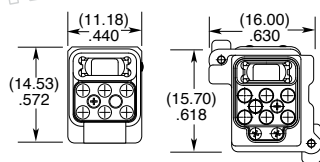

-A FEMALE **-A MALE**

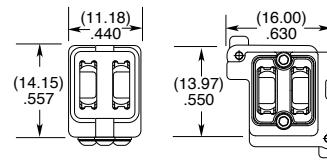

-B FEMALE **-B MALE**

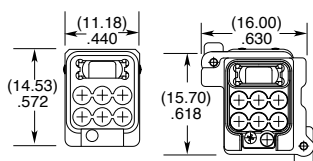

-C FEMALE **-C MALE**

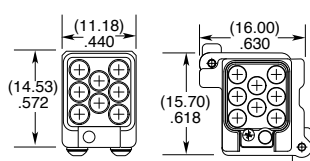

-D FEMALE **-D MALE**

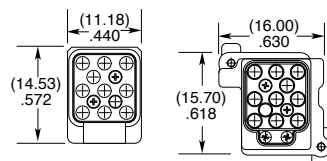

-E FEMALE **-E MALE**

View complete specifications at: samtec.com?VBM

CONTACT OPTIONS

GPCC	SIZE	SERIES	GENDER	TYPE	PLATING	CABLE CALLOUT	ORIENTATION	OPTION
	-16 = Size 16 -20 = Size 20	-N = Size 16 only -V = Size 20 only	-P = Pin (For VBM-M block only) -S = Socket (For VBM-F block only)	-C = Cable	GG = 10 μ" (0.25 μm) Gold center contact, 10 μ" (0.25 μm) Gold outer body	-086F = CCA-086F-PTFE, 75 Ω (Size 16, pin only) -047J = CCA-047J-PTFE, 75 Ω (Size 16, socket only) -047A = CCA-047-PFA, 50 Ω (Size 20 only)	-SD = Direct Solder	-1 -2 (Socket, Size 20 only)



-16 PIN

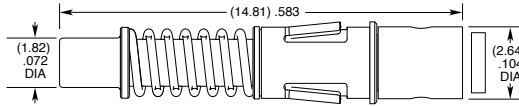

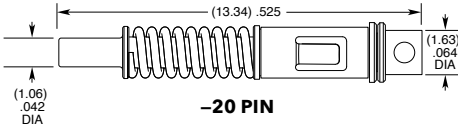

-20 PIN

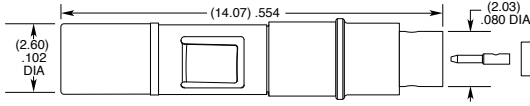

-16 SOCKET

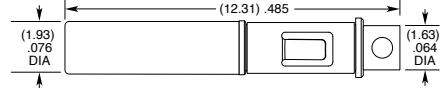

-20 SOCKET

CABLE ASSEMBLY OPTIONS

View complete specifications at: samtec.com?GPCC-16 or samtec.com?GPCC-20

RF047-A	END 1 CONNECTOR	END 2 CONNECTOR	OVERALL LENGTH
	-MTSJ = Threaded SMPM Jack -M0SJ = SMPM Jack -20VP = Size 20 Pin -20VS = Size 20 Socket		-"XXXX" = Overall Length in millimeters -0100 (100 mm) 3.94" minimum



ALSO AVAILABLE

1.00 mm, 1.35 mm, 1.85 mm, 2.40 mm, 2.92 mm, SMA

OPTICAL OPTIONS

View complete specifications at: samtec.com?RF047-A

Samtec's rugged mid-board optical transceivers are available with industry standard MT ferrule end options: FireFly™, FireHawk™ and Halo®. Contact RFGroup@samtec.com for assistance with this solution.

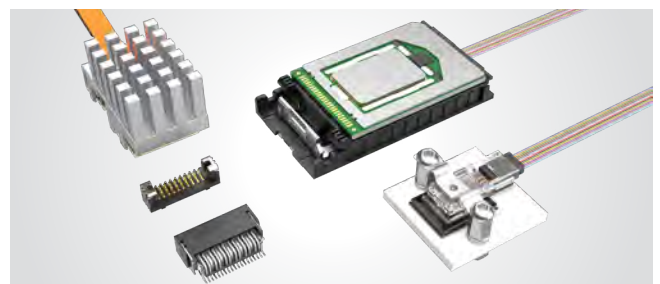

NEXT GEN FLEXIBLE WAVEGUIDE

HIGH FREQUENCY • FLEXIBLE CABLE • SMALL FORM FACTOR • LOW LOSS

Samtec's new, high frequency micro waveguide technology is designed to support the demands of next generation millimeter wave systems. It uses a cable design allowing flexibility and a reduced size, and supports frequencies up to 75 GHz (V-band), but with a loss performance greatly improved over coaxial cables.

V-BAND CABLE

V-Band Cable Assemblies WF15

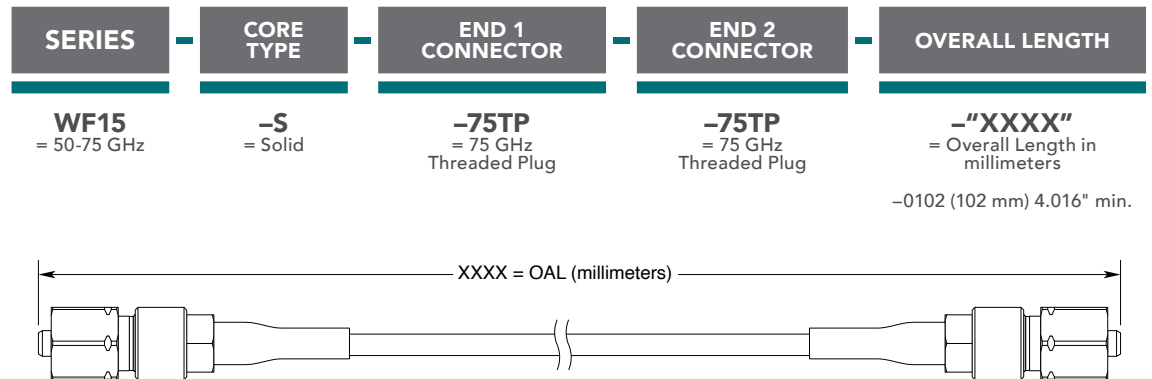
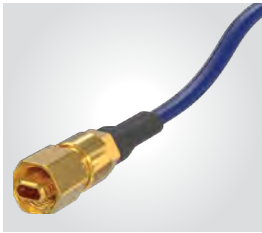

ADAPTORS

V-Band Adaptors WGBA

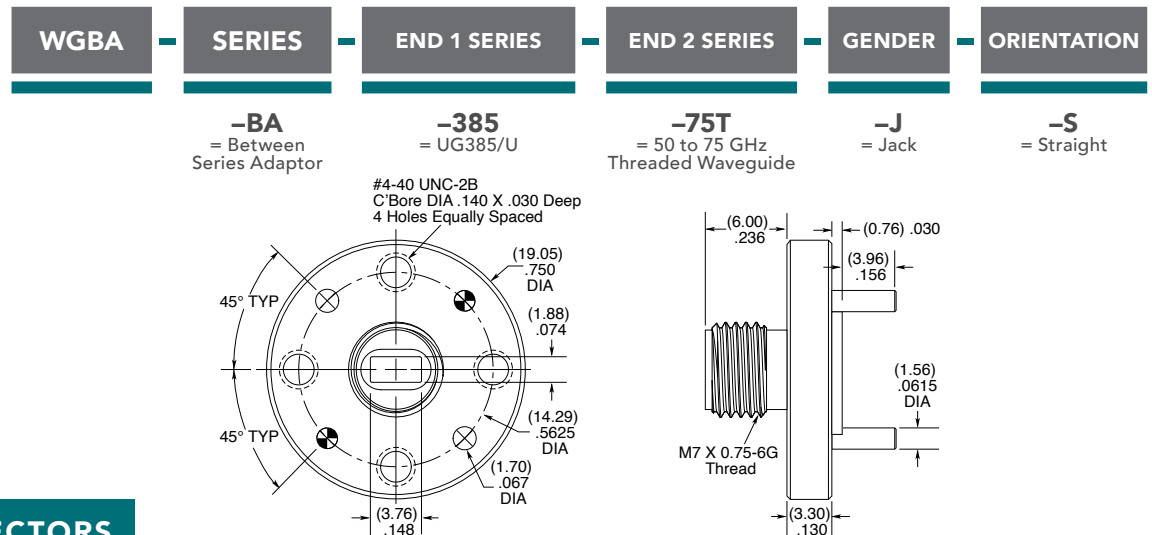

BOARD CONNECTORS

V-Band Board Connectors 75T

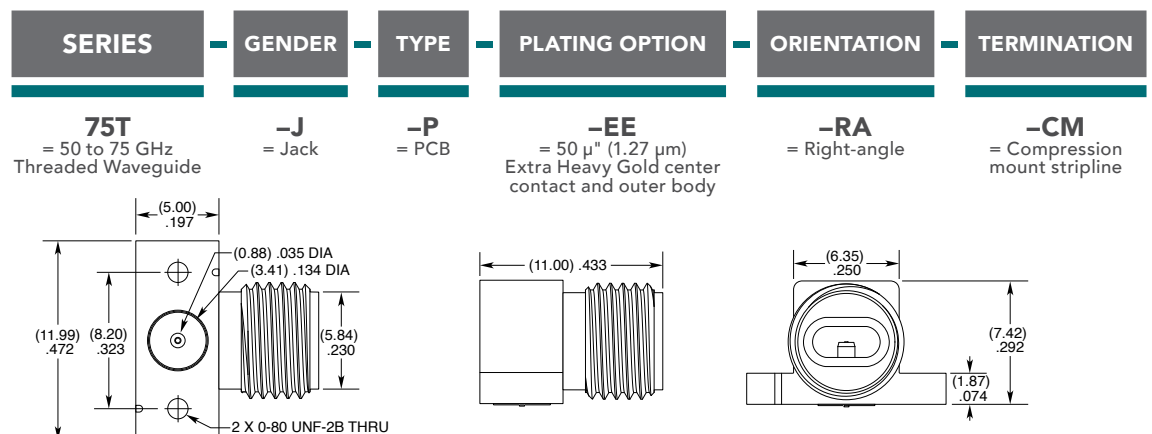
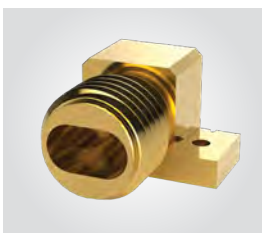

LOW FREQUENCY CABLE SPECIFICATIONS



STANDARD OFF-THE-SHELF ASSEMBLIES

SERIES	MH081	MH113	RF178	RF174	IJ5C [†] (IsoRate [®])	RF316, IJ5C, IJ5H, GRF1-C, GRF1H-C	RS316	RF058	RF179, GRF7-C, GRF7H-C	RFB8T	RFC8T	RFB6T	RFC6T	RFA6T	C28S		
TYPE	50 Ω CABLES								75 Ω CABLES						100 Ω CABLES		
	0.81 mm (34 AWG)	1.13 mm (31 AWG)	RG 178 (28 AWG)	RG 174 (24 AWG)	Samtec 26 AWG, high-temp micro coax	RG 316 (24 AWG)	RG 316, double shielded (24 AWG)	RG 58 (20 AWG)	RG 179 (28 AWG)	Belden 1855A (23 AWG)	12G-SDI, Belden 4855R (23 AWG)	Belden 1694A (18 AWG)	12G- SDI, Belden 4694R (18 AWG)	RG 6 (18 AWG)	Samtec 28 AWG, shielded twisted pair		
ELECTRICAL																	
Impedance	Ω	50 ± 3	50 ± 2	50 ± 5	50 ± 2	50 ± 3	75 ± 3						100 ± 5				
Insertion Loss (dB/m)	100 MHz	1.00	0.60	0.50	0.40	0.68	0.30	1.40 @ 2 GHz	0.20	0.30	0.12		0.07	0.06	0.07	-----	
	1 GHz	3.10	1.90	1.70	1.40	2.37	1.25	1.60 @ 3 GHz	0.80	0.80	0.37	0.36	0.21	0.19	0.21	-----	
	6 GHz	8.60	4.90	5.90	4.40	6.53	4.25	2.20 @ 5 GHz	5.40	3.60	0.97	0.91	0.59	0.51	0.59	-----	
Propagation Delay	nS/m	4.70	4.70	4.83	5.06	4.17	4.83	-----	5.05	4.83	4.12		4.06		3.92	4.03	-----
Current Rating	Amps	1.20	2.10	3.00	5.00	3.00	5.00	-----	-----	3.00	5.00	4.70	-----	16.00	-----		
Capacitance	pF/m	100.00	95.00	96.00	101.00	85.60	96.00	95.80	102.00	64.00	55.70	53.40	53.14	52.20	53.14	38.00	
CONSTRUCTION																	
Center Conductor	Material	Silver Plated Copper		Silver Plated Copper Clad Steel	Bare Copper	Silver Plated Copper	Silver and Copper Plated Steel	Silver Plated Copper Clad Steel	Tinned Copper	Silver Plated Copper	Bare Copper	Silver Plated Copper	Bare Copper	Silver Plated Copper	Bare Copper	Silver Plated Copper	
	AWG	34	31	28	24	26	24		20	28	23		18		28		
Dielectric	Material	FEP		PTFE	KLPE	Foamed FEP	PTFE	FEP	Solid Polyethylene	PTFE	FHDPE	PE (Foam)	FHDPE	PE (Foam)	FHDPE	FEP	
Shield	Material	Silver Plated Copper	Tinned Copper	Silver Plated Copper	Tinned Copper	Silver Plated Copper			Tinned Copper	Silver Plated Copper	1. Al Foil-Polyester Tape-Al Foil 2. Tinned Copper		1. Bonded Al Foil 2. Al Wire		1. Al Foil-Polyester Tape-Al Foil 2. Tinned Copper		Silver Plated Copper
Jacket	Material	PFA	FEP		PVC	FEP			PVC	FEP	PVC						
MECHANICAL																	
Operating Temp		-40 °C to +90 °C		-50 °C to +165 °C	-20 °C to +80 °C	-40 °C to +200 °C	-55 °C to +165 °C		-50 °C to +90 °C	-50 °C to +165 °C	-30 °C to +75 °C		-20 °C to +75 °C	-30 °C to +75 °C	-20 °C to +105 °C		
Bend Radius	Min	5.00 mm	6.80 mm	10.20 mm	25.40 mm	3.18 mm	12.80 mm	12.80 mm	49.50 mm	10.20 mm	38.10 mm	41.00 mm	69.85 mm	70.00 mm	69.85 mm	19.05 mm	
Connector Options		MHF1, MHF3, MHF4	MHF1, SMA	MMCX, MCX, SMA, SMB, BNC, TNC, N Type	MMCX, MMCXV, MCX, SMA, SMB, BNC, TNC, N Type, Ganged	IsoRate [®]	MMCX, MMCXV, MCX, SMA, SMB, BNC, TNC, N Type, Ganged	MMCX, MCX, SMA, SMB, BNC, TNC	SMA, TNC, N Type	MCX, MMCX7, SMB, BNC, DIN 1.0/2.3, Ganged	HD-BNC, DIN 1.0/2.3		BNC, HD-BNC, DIN 1.0/2.3		CJT		

[†] ALSO USES RG 316

RUGGED U.FL / MHF® 1 SOLUTIONS

FEATURES

- Extended ferrule length provides a metalized strain relief for increased durability
- 500 mating cycles
- Mixed technology PCB connector for improved durability, prevents shearing (RSP-237256-XX)
- Intermateable with industry standard U.FL/MHF® 1 board connectors (RSP-122811-01)
- 50 Ohm impedance
- Frequency: DC to 10 GHz
- .047" low-loss flexible cable, 29 AWG (RF047-A)
- Mated height (with right-angle cable connector):
 - 4 mm max. (-11RP9 HMHF1 + RSP-122811-01)
 - 4.75 mm max. (-11RP9 HMHF1 + RSP-237256-XX)
- Visit samtec.com/rugged-ufl or contact RFGroup@samtec.com for more information

Extended ferrule protects solder joint for a rugged, durable connection



500 mating cycles

MATED HEIGHTS

Max 4.75 mm

Max 4 mm



50 Ω U.FL/MHF® 1 RF CABLE TO 10 GHZ

MHF® is a registered trademark of I-PEX® Inc.

SERIES

RF047-A

= (1.2 mm) .047" overshield DIA
29 AWG millimeter wave cable

END 1 CONNECTOR

Specify END OPTION from chart

END 2 CONNECTOR

OVERALL LENGTH

-"XXXX"

= Overall Length in millimeters

-0100 (100 mm) 3.94" minimum

U.FL/MHF® 1 Cable Assemblies

RF047-A



PRELIMINARY

STRIPPED & TINNED (Dimensions in mm)

CALLOUT	A	B	C
-303030	3.0	3.0	3.0
-303040	3.0	3.0	4.0
-403030	4.0	3.0	3.0
-403040	4.0	3.0	4.0
-404040	4.0	4.0	4.0

Both center conductor and braid shield are stripped, only the center conductor is tinned.

RELATED SOLUTIONS

Micro High Frequency (MHF® 1) to 6 GHz

- On 0.81 mm cable (MH081 Series)

- On 1.13 mm cable (MH113 Series)

END OPTIONS

-11SP9 = HMHF1

U.FL/MHF® 1 Straight Plug

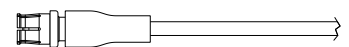

-11RP9 = HMHF1

U.FL/MHF® 1 Right-Angle Plug, Metal Strain Relief



-SING =

Single Ended (End 2 Callout)



-XXXXXX =

Stripped & Tinned (End 2 Callout)

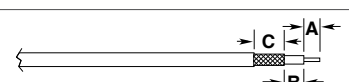

50 Ω MICRO HIGH FREQUENCY RF CABLES TO 6 GHz

MHF® Cable Assemblies MH081, MH113



SPECIFICATIONS

Outer Contact Material:
Au plated Phosphor Bronze
Center Contact Material:
Au plated Phosphor Bronze (MHX)
Au plated BeCu (SMA)
Insulator Material:
PBT (MHX)
PTFE (SMA)
Operating Temperature:
-40 °C to +90 °C
Voltage Rating:
170 V max
Dielectric Withstanding Voltage:
200 Vrms

0.81 mm Cable:

Capacitance:
100 pF/meter
Max Attenuation (cable only):
3.1 dB @ 1 GHz
Conductor Size:
36 AWG, (0.81 mm) .032" dia.
Conductor Material:
Silver Plated Copper
Conductor Resistance:
1.40 Ω/meter max
Insulator Diameter:
(0.4 mm) .016"
Insulator Material: FEP
Shield Material:
Silver Plated Copper
Jacket Material: PFA
Jacket Diameter:
(0.81 mm) .032" dia.
Bend Radius: 5.0 mm
Jacket Temp Rating:
-40 °C to +90 °C

1.13 mm Cable:

Capacitance:
95 pF/meter
Max Attenuation (cable only):
2 dB @ 1 GHz
Conductor Size:
32 AWG, (1.13 mm) .045" dia.
Conductor Material:
Silver Plated Copper
Conductor Resistance:
0.60 Ω/meter max
Insulator Diameter:
(0.66 mm) .026"
Insulator Material:
FEP
Shield Material:
Tinned Copper
Jacket Material:
FEP
Jacket Diameter:
(1.13 mm) .045" dia
Bend Radius:
6.8 mm
Jacket Temp Rating:
-40 °C to +90 °C

SERIES	END 1 CONNECTOR	END 2 CONNECTOR	OVERALL LENGTH
--------	-----------------	-----------------	----------------

MH081
= 0.81 mm Cable
MH113
= 1.13 mm Cable

Specify END OPTIONS from chart

-0030
= 1.18" (30 mm)
-0050
= 1.97" (50 mm)
-0100
= 3.94" (100 mm)
-0150
= 5.91" (150 mm)
-0300
= 11.81" (300 mm)

APPLICATION

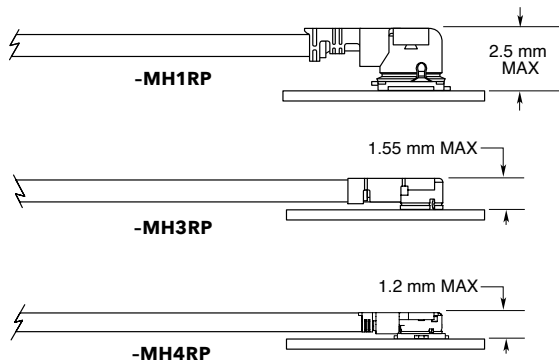

EXTRACTION TOOLS

MH1RP = RSP-122893-01
MH3RP = RSP-122893-02
MH4RP = RSP-122893-03

MATING SOLUTIONS

MH1RP end mates with RSP-122811-01 (Cycles: 30 max.)

MH3RP end mates with RSP-122811-02

MH4RP end mates with RSP-122811-03



MHF® is a registered trademark of I-PEX® Inc.

END OPTIONS

<p>-MH1RP = MHF1 Type Plug (3.9 μ" (0.1 μm) Gold on Center Contact, 1.9 μ" (0.05 μm) Gold on Shell)</p>	
<p>-MH3RP = MHF3 Type Plug (3.9 μ" (0.1 μm) Gold on Center Contact, 1.9 μ" (0.05 μm) Gold on Shell) (MH081 only)</p>	
<p>-MH4RP = MHF4 Type Plug (10 μ" (0.25 μm) Gold on Center Contact, 1.9 μ" (0.05 μm) Gold on Shell) (MH4RP is not available with MH1RP & MH3RP) (MH081 only)</p>	
<p>-01BJ1 = SMA Straight Bulkhead Jack (MH081 only) -01BJ2 = SMA Straight Bulkhead Jack, Reversed Polarity -01SB1 = SMA Straight Jack, Sealed Bulkhead -01SR1 = SMA Straight Jack, Sealed Bulkhead, Reversed Polarity (30 μ" (0.76 μm) Gold on Center Contact, Gold Flash on Shell)</p>	
<p>-SING = Single Ended (End 2 callout)</p>	
<p>XXXXXX = Stripped & Tinned (End 2 callout)</p>	

STRIPPED & TINNED (Dimensions in mm)

CALLOUT	A	B	C
-303030	3.0	3.0	3.0
-303040	3.0	3.0	4.0
-403030	4.0	3.0	3.0
-403040	4.0	3.0	4.0
-404040	4.0	4.0	4.0

Both center conductor and braid shield are stripped, only the center conductor is tinned.

50 Ω SMA TO 6 GHz

SMA Cable Assemblies

RF174, RF178, RF316, RS316, RF058



SERIES	END 1 CONNECTOR	END 2 CONNECTOR	OVERALL LENGTH
RF174 = RG 174 Cable	-01SP1 = SMA Straight Plug		-“XXXX” = Overall Length in millimeters
RF178 = RG 178 Cable (-01BJ1 & -01BR1 only)	-01RP1 = SMA Right-angle Plug		-0100 (100 mm) 3.94" minimum
RF316 = RG 316 Cable, Single Braid Shield	-01BJ1 = SMA Straight Bulkhead Jack		
RS316 = RG 316 Cable, Double Shield (-01SP1 & -01BJ1 only)	-01SB1 = Straight Bulkhead Jack, Sealed		
RF058 = RG 58 Cable (-01SP1, -01BJ1 & -01SB1 only)	-01SR1 = Straight Bulkhead Jack, Sealed, Reversed Polarity		
	-01BR1 = Straight Bulkhead Jack, Reversed Polarity		
	-01PN1 = 4-Hole Panel Mount Jack		

ALSO AVAILABLE

50 Ω: MCX, MMCX, SMB, BNC, TNC,
N Type = RF174, RF178, RF316

50 Ω: MCX, MMCX, BNC, TNC = RS316

50 Ω: TNC = RF058

SMA Cable Connectors

SMA-CA



Supplied with pins, washers, nuts and ferrules. See website for dimensions.

SMA	GENDER	TYPE	PLATING	ORIENTATION	TERMINATION	PACKAGING	
	-J = Jack	-C = Cable -C4 = Cable 4-Mounting Screws (-PN1 only)	-H = 30 μ" (0.76 μm) Gold center contact, 3 μ" (0.08 μm) Gold outer contact (N/A with -BH1S)	-ST = Straight	-BH1 = Bulkhead RG 174 / 316 Cable -BH2 = Bulkhead RG 178 Cable -BR1 = Bulkhead RG 174 / 316, Reversed Polarity -BR2 = Bulkhead RG 178 Cable, Reversed Polarity	-BH1S = Bulkhead RG 316 Cable, Double Shield -B10 = Bulkhead RG 58 Cable -PN1 = 4-Hole Panel Mount RG 174 / 316 Cable -S10 = Sealed Bulkhead RG 58 Cable	Leave blank for individually bagged. -B = Bulk packaged (-BH1 only)
			-HF = 30 μ" (0.76 μm) Gold center contact, 3 μ" (0.08 μm) Gold outer contact (-BH1S only)				

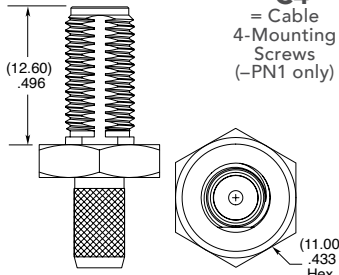

SMA Board Connectors

See page 163 for Board Connectors

SMA	GENDER	TYPE	PLATING	ORIENTATION	TERMINATION	PACKAGING
	-P = Plug	-C = Cable	-H = 30 μ" (0.76 μm) Gold center contact, 3 μ" (0.08 μm) Gold outer contact (-CA1, -C10 only)	-ST = Straight -RA = Right-angle	-CA1 = RG 174 / 316 Cable -C10 = RG 58 Cable (-ST only) -CA1S = RG 316 Double Shielded Cable (-ST only)	Leave blank for individually bagged. -B = Bulk packaged (-CA1 only)
			-HF = 30 μ" (0.76 μm) Gold center contact, 3 μ" (0.08 μm) Gold outer contact (-CA1S only)			

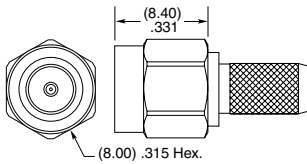

Supplied with pins, washers, nuts and ferrules. See website for dimensions.

50 Ω MCX TO 6 GHz

MCX Cable Assemblies

RF174, RF178, RF316, RS316



SERIES	END 1 CONNECTOR	END 2 CONNECTOR	OVERALL LENGTH
RF174 = RG 174 Cable	-02SJ1 = MCX Straight Jack		-“XXXX” = Overall Length in millimeters
RF178 = RG 178 Cable	-02RP1 = MCX Right-angle Plug (RS316 not available)		-0100 (100 mm) 3.94" minimum
RF316 = RG 316 Cable, Single Braid Shield	-02SP1 = MCX Straight Plug		
RS316 = RG 316 Cable, Double Shielded			

ALSO AVAILABLE

50 Ω: MMCX, SMA, SMB, BNC, TNC,
N Type = RF174, RF178, RF316
50 Ω: MMCX, SMA, BNC, TNC = RS316

MCX Board Connectors

MCX-TH, MCX-SM, MCX-EM, MCX-MT

Cable Mates:

RF174, RF178, RF316, RS316, GRF1H-C, IJ5H



MCX	GENDER	TYPE	PLATING	ORIENTATION	TERMINATION
	-J = Jack	-P = PCB Mount	-H = 30 μ" (0.76 μm) Gold center contact, 3 μ" (0.08 μm) Gold outer contact	-ST = Straight	-TH1 = Through-hole (-ST plug not available)
	-P = Plug			-RA = Right-angle	-TH2 = Elevated Through-hole (-ST plug only)
					-SM1 = Surface Mount (Jack only)
					-EM1 = Edge Mount (-ST jack only)
					-MT1 = Mixed Technology (-ST jack only)

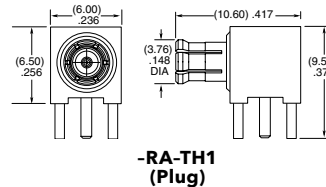
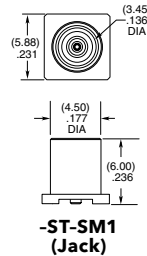

MCX Cable Connectors

MCX-CA



CONNECTORS FOR INDUSTRY STANDARD CABLES	
MCX-J-C-H-ST-CA1	RG 174/316 Cable
*MCX-J-C-H-ST-CA2	RG 178 Cable
MCX-J-C-HF-ST-CA1S	RG 316 Double Shielded Cable
*MCX-P-C-H-ST-CA1	RG 174/316 Cable
MCX-P-C-H-ST-CA2	RG 178 Cable
MCX-P-C-HF-ST-CA1S	RG 316 Double Shielded Cable
*MCX-P-C-H-RA-CA1	RG 174/316 Cable
MCX-P-C-H-RA-CA2	RG 178 Cable

P-C = Cable Plug
J-C = Cable Jack
H or HF = Plating (30 μ" Gold center contact, 3 μ" Gold outer contact)
ST = Straight
RA = Right-angle

*Add "-B" to the end of the part number for bulk packaging

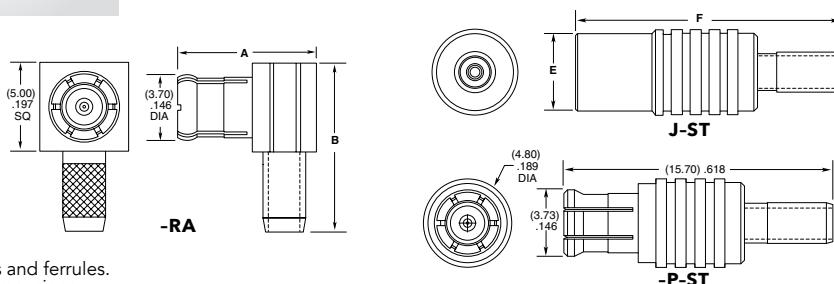

Supplied with pins and ferrules. See website for dimensions.

TYPE (-RA)	A	B
-P-CA1	(7.78) .306	(9.50) .374
-P-CA2	(8.58) .338	(10.00) .394

TYPE (-ST)	E	F
-J-CA1	(4.50) .177	(15.50) .610
-J-CA2	(4.78) .188	(15.00) .591
-J-CA1S	(4.50) .177	(15.50) .610

50 Ω MMCX TO 6 GHz

MMCX Cable Assemblies

RF174, RF178, RF316, RS316



SERIES	END 1 CONNECTOR	END 2 CONNECTOR	OVERALL LENGTH
RF174 = RG 174 Cable	-03SP1 = MMCX Straight Plug		-“XXXX” = Overall Length in millimeters -0100 (100 mm) 3.94" minimum
RF178 = RG 178 Cable (-03SP1 & -03RP1 only)	-03RP1 = MMCX Right-angle Plug		
RF316 = RG 316 Cable, Single Braid Shield	-V3SP1 = MMCXV Straight Plug, High Vibration		
RS316 = RG 316 Cable, Double Shielded (-03SP1 only)	-V3RP1 = MMCXV Right-angle Plug, High Vibration		
		-V3SJ1 = MMCXV Straight Jack, High Vibration	

ALSO AVAILABLE

50 Ω: MCX, SMA, SMB, BNC, TNC, N Type = RF174, RF178, RF316
50 Ω: MCX, SMA, BNC, TNC = RS316

MMCX Board Connectors

MMCX-SM, MMCX-TH, MMCX-MT, MMCX-EM

Cable Mates:
RF174, RF178, RF316, RS316, GRF1H-C, IJ5H



MMCX	GENDER	TYPE	PLATING	ORIENTATION	TERMINATION
	-J = Jack	-P = PCB Mount	-H = 30 μ" (0.76 μm) Gold center contact, 3 μ" (0.08 μm) Gold outer contact	-ST = Straight -RA = Right-angle	-TH1 = Through-hole -MT1 = Mixed Technology (-ST only) -SM1 = Surface Mount (-RA plug not available) -EM1 = Edge Mount (-ST only)

-ST-SM1 (Jack)

-RA-TH1 (Plug)

MMCX Cable Connectors

MMCX-CA



CONNECTORS FOR INDUSTRY STANDARD CABLES	
MMCX-P-C-H-ST-CA1	RG 174/316 Cable
MMCX-P-C-H-ST-CA2	RG 178 Cable
MMCX-P-C-HF-ST-CA1S	RG 316 Double Shielded Cable
MMCX-P-C-H-RA-CA1	RG 174/316 Cable
MMCX-P-C-H-RA-CA2	RG 178 Cable

Add "-B" to the end of the part number for bulk packaging
P-C = Cable Plug
H or HF = Plating (30 μ" Gold center contact, 3 μ" Gold outer contact)
ST = Straight
RA = Right-angle

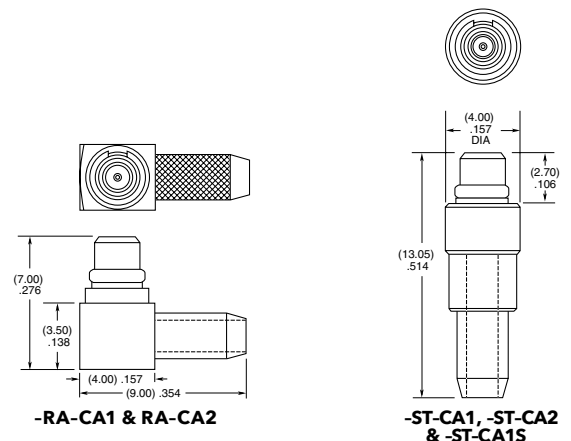

Supplied with pins and ferrules. See website for dimensions.

50 Ω TNC TO 6 GHz

TNC Cable Assemblies

RF174, RF178, RF316, RS316, RF058

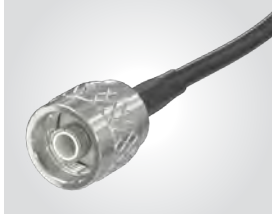

SERIES	END 1 CONNECTOR	END 2 CONNECTOR	OVERALL LENGTH
RF174 = RG 174 Cable	-05SP3 = TNC Straight Plug (RF058 not available)	-05BJ3 = TNC Straight Bulkhead Jack (RS316 & RF058 not available)	-“XXXX” = Overall Length in millimeters -0100 (100 mm) 3.94” minimum
RF178 = RG 178 Cable			
RF316 = RG 316 Cable, Single Braid Shield			
RS316 = RG 316 Cable, Double Shielded			
RF058 = RG 58 Cable			

ALSO AVAILABLE

50 Ω: MCX, MMCX, SMA, SMB, BNC,
N Type = RF174, RF178, RF316

50 Ω: MCX, MMCX, SMA, BNC = RS316

50 Ω: SMA, N Type = RF058

TNC Board Connectors

TNC-TH

Cable Mates:

RF174, RF178, RF316, RS316, RF058, GRF1H-C



TNC	GENDER	TYPE	PLATING	ORIENTATION	TERMINATION
	-J = Jack	-P = PCB Mount	-H = 30 μ" (0.76 μm) Gold center contact, Nickel on shell	-RA = Right-angle	-TH1 = Through-hole

TNC Cable Connectors

TNC-CA



CONNECTORS FOR INDUSTRY STANDARD CABLES	
TNC-P-C-GN-ST-CA1	RG 174/316 Cable
TNC-P-C-GN-ST-CA2	RG 178 Cable
TNC-P-C-GN-SR-C10	RG 58 Cable
TNC-J-C-GN-ST-BH1	RG 174/316 Cable, Bulkhead
TNC-J-C-GN-ST-BH2	RG 178 Cable, Bulkhead

P-C = Cable Plug
J-C = Cable Jack
GN = Plating (10 μ" Gold on contact, Nickel on body)
ST = Straight
SR = Straight Reverse Polarity

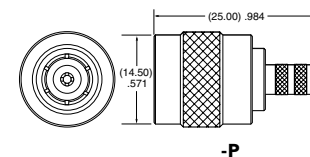
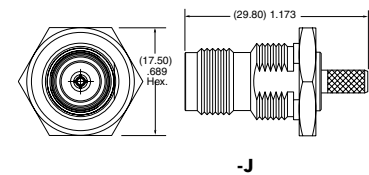

Supplied with pins, washers, nuts and ferrules. See website for dimensions.

50 Ω BNC TO 4 GHz

BNC Cable Assemblies

RF174, RF178, RF316, RS316



SERIES	END 1 CONNECTOR	END 2 CONNECTOR	OVERALL LENGTH
RF174 = RG 174 Cable	-04SP3 = BNC Straight Plug (RS316 not available)	-04BJ2 = BNC Bulkhead Jack	-"XXXX" = Overall Length in millimeters -0100 (100 mm) 3.94" minimum
RF178 = RG 178 Cable			
RF316 = RG 316 Cable, Single Braid Shield			
RS316 = RG 316 Cable, Double Shielded			
ALSO AVAILABLE			
50 Ω: MCX, MMCX, SMA, SMB, TNC, N Type = RF174, RF178, RF316			
50 Ω: MCX, MMCX, SMA, TNC = RS316			

BNC Cable Connectors

BNC5-CA



Supplied with pins, washers, nuts, gaskets and ferrules. See website for dimensions.

CONNECTORS FOR INDUSTRY STANDARD CABLES	
*BNC5-P-C-GN-ST-CA1	RG 174/316 Cable
*BNC5-P-C-GN-ST-CA2	RG 178 Cable
*BNC5-J-C-GN-ST-BH1	RG 174/316 Cable, Bulkhead
BNC5-J-C-GN-ST-BH2	RG 178 Cable, Bulkhead
BNC5-J-C-GN-ST-BH1S	RG 316 Double Shielded Cable, Bulkhead

*Add "-B" to the end of the part number for bulk packaging

P-C = Cable Plug

J-C = Cable Jack

GN = Plating (10 μ" Gold on contact, Nickel on body)

ST = Straight



50 Ω SMB TO 4 GHz

SMB Cable Assemblies

RF174, RF178, RF316



SERIES	END 1 CONNECTOR	END 2 CONNECTOR	OVERALL LENGTH
RF174 = RG 174 Cable	-07SP1 = SMB Straight Plug		-“XXXX” = Overall Length in millimeters
RF178 = RG 178 Cable	-07RP1 = SMB Right-angle Plug		-0100 (100 mm) 3.94" minimum
RF316 = RG 316 Cable, Single Braid Shield	-07BJ1 = SMB Bulkhead Jack		
	-07BJ2 = SMB Bulkhead Jack (RF178 only)		

ALSO AVAILABLE

50 Ω: MCX, MMCX, SMA, BNC, TNC,
N Type = RF174, RF178, RF316

SMB Board Connectors

SMB5-TH

Cable Mates:
RF174, RF178, RF316,
GRF1H-C, IJ5H

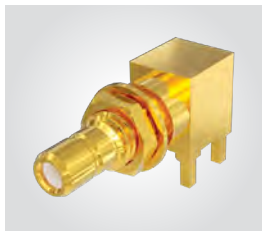

SMB5	GENDER	TYPE	PLATING	ORIENTATION	TERMINATION
	-J = Jack	-P = PCB Mount	-H = 30 μ" (0.76 μm) Gold center contact, 3 μ" (0.08 μm) Gold outer contact	-RA = Right-angle	-TH1 = Through-hole

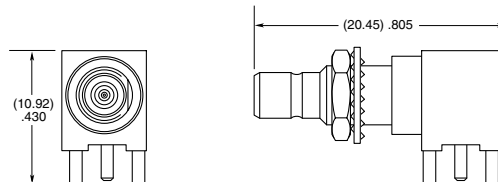

SMB Cable Connectors

SMB5-CA



CONNECTORS FOR INDUSTRY STANDARD CABLES	
SMB5-P-C-H-ST-CA1	RG 174/316 Cable
SMB5-P-C-H-RA-CA1	RG 174/316 Cable
SMB5-J-C-H-ST-CA2	RG 178 Cable
SMB5-J-C-H-ST-BH1	RG 316 Cable, Bulkhead

P-C = Cable Plug
J-C = Cable Jack
H = Plating (30 μ" Gold center contact, 3 μ" Gold on outer contact)
ST = Straight
RA = Right-angle

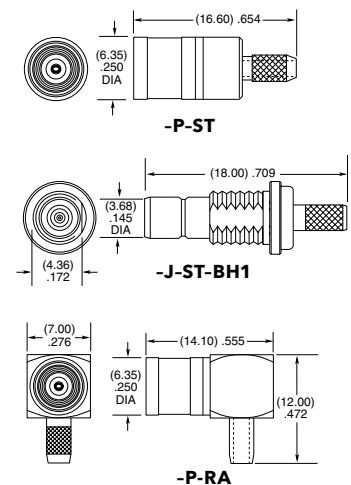

Supplied with pins, washers, nuts and ferrules. See website for dimensions.



75 Ω BNC TO 12 GHz

BNC Cable Assemblies

RFC6T, RFA6T, RFB6T, RF179



SERIES	END 1 CONNECTOR	END 2 CONNECTOR	OVERALL LENGTH
RFC6T* = 12G-SDI, Belden 4694R Cable	-74SP3 = 75 Ω BNC Straight Plug		-“XXXX” = Overall Length in millimeters -0300 (300 mm) 11.81" minimum (RFA6T, RFB6T, RFC6T) -0100 (100 mm) 3.94" minimum (RF179)
RFA6T = RG 6 Cable	-D4SP3 = 75 Ω BNC Die Cast Straight Plug (RFA6T, RFB6T, RF179 only)		
RFB6T = Belden 1694A Cable	-74BJ3 = 75 Ω BNC Bulkhead Jack (RF179 only)		
RF179 = RG 179 Cable	-74RP3 = 75 Ω BNC Right-angle Plug (RFA6T, RFB6T, RFC6T only)		

ALSO AVAILABLE

75 Ω: DIN 1.0/2.3, HDBNC = RFA6T, RFB6T, RFC6T

75 Ω: DIN 1.0/2.3, SMB, MCX, MMCX = RF179

*Designed to meet SMPTE 2082 12G-SDI specifications.

BNC Cable Connectors

BNC7T-CA



Supplied with pins, washers, nuts, gaskets and ferrules. See website for dimensions.

CONNECTORS FOR INDUSTRY STANDARD CABLES	
**BNC7T-P-C-GN-ST-CA3	Machined, RG 179 Cable
**BNC7T-P-C-GN-RA-CA3	Machined, RG 179 Cable
**BNC7T-P-C-GN-ST-CA6	*Machined, RG 6 Cable
**BNC7T-P-C-GN-RA-CA6	*Machined, RG 6 Cable
**BNC7T-P-C-GN-ST-CA6B	Belden 4694R Cable
**BNC7T-P-C-GN-RA-CA6B	Belden 4694R Cable
**BNC7T-J-C-GN-ST-BH3	Machined, Bulkhead, RG 179 Cable
BNC7T-P-C-GN-ST-CA3D	Die Cast, RG 179 Cable
BNC7T-P-C-GN-ST-CA6D	Die Cast, RG 179 Cable

P-C = Cable Plug
J-C = Cable Jack
GN = Plating (10 μ" Gold on contact, Nickel on outer contact and shell)
ST = Straight
RA = Right-angle

**Add "-B" to the end of the part number for bulk packaging

*Designed to meet SMPTE 2082 12G-SDI specifications.

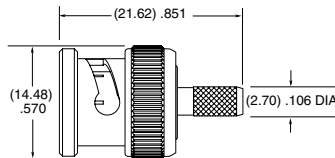

-CA3D

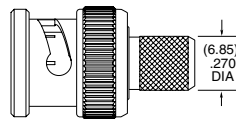

-CA6D

DIE CAST

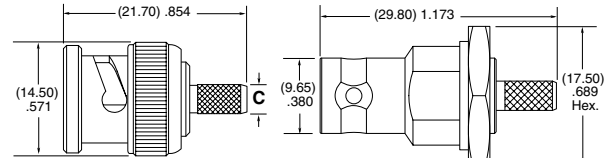

-P-ST-CA3 & -P-ST-CA6

-J-ST-BH3

MACHINED

TERMINATION	C (DIA)
-CA3	(2.70) .106
-CA6	(6.85) .270

Note:
Additional plating options available on Cable Assemblies, Cable Connectors and Board Connectors. Contact RFGroup@samtec.com

75 Ω DIE CAST BNC TO 12 GHz

BNC Board Connectors
BNC7T-TH, BNC7T-BH,
BNC7T-BM, BNC7T-EM

Cable Mates:
RF179, RFA6T, RFB6T,
RFC6T, GRF7H-C



BNC7T	GENDER	TYPE	PLATING	ORIENTATION	TERMINATION	PACKAGING
	-J = Jack	-P = PCB Mount	-GN = 10 μ" (0.25 μm) Gold contact, 100 μ" (2.54 μm) Nickel Shell	-ST = Straight -RA = Right-angle Bulkhead/Panel Mount	-TH2D = Tall Through-hole Die Cast (-ST only) -BH2D* = Low Profile Die Cast Bulkhead Through-hole (-RA only) -BM1D* = Low Profile Die Cast Bulkhead Mixed Technology for (1.60 mm) .062" PCB (-RA only) -BM2D* = Low Profile Die Cast Bulkhead Mixed Technology for (3.18 mm) .125" PCB (-RA only) -EM1D* = Edge Mount Die Cast Bulkhead/Panel Mount for (1.60 mm) .062" PCB (-ST only) -EM2D* = Edge Mount Die Cast Bulkhead/Panel Mount for (2.40 mm) .093" PCB (-ST only)	Leave blank for individually bagged. -B = Bulk packaged (-BH2D only)
	<p>-RA-BM1D (BALANCED FOR PICK-AND-PLACE)</p>		<p>-RA-BH2D</p>		<p>-ST-EM1D & -ST-EM2D</p>	
			<p>-ST-TH2D</p>		<p>*Lock washers & knurled nuts supplied with bulkhead/panel mount options</p>	

Notes:
Contact RFGroup@samtec.com for 12G-SDI PCB mount launch characteristics.

Designed to meet SMPTE 2082 12G-SDI specifications.

Additional plating options available on Board Connectors. Contact RFGroup@samtec.com

75 Ω MACHINED BNC TO 12 GHz

BNC Board Connectors
BNC7T-TH, BNC7T-BH,
BNC7T-EM

Cable Mates:
RF179, RFA6T, RFB6T,
RFC6T, GRF7H-C



BNC7T	GENDER	TYPE	PLATING	ORIENTATION	TERMINATION	PACKAGING
	-J = Jack	-P = PCB Mount	-GN = 10 μ" (0.25 μm) Gold contact, 100 μ" (2.54 μm) Nickel Shell	-ST = Straight -RA = Right-angle Bulkhead/Panel Mount	-TH1 = Standard Through-hole (-ST only) -BH1* = Standard Bulkhead Through-hole (-RA only) -EM1* = Edge Mount Bulkhead/Panel Mount for (1.60 mm) .062" PCB (-ST only) -EM2* = Edge Mount Bulkhead/Panel Mount for (2.40 mm) .093" PCB (-ST only)	Leave blank for individually bagged. -B = Bulk packaged (-BH1 only)
	<p>-ST-EM1 & -ST-EM2</p>		<p>-ST-TH1</p>		<p>*Lock washers & knurled nuts supplied with bulkhead/panel mount options</p>	
	<p>-RA-BH1</p>					

Notes:
Contact RFGroup@samtec.com for 12G-SDI PCB mount launch characteristics.

Designed to meet SMPTE 2082 12G-SDI specifications.

Additional plating options available on Board Connectors. Contact RFGroup@samtec.com

75 Ω HIGH-DENSITY BNC TO 12 GHz

HIGH-DENSITY BNC Cable Assemblies

RFA6T, RFB6T, RFB8T, RFC6T, RFC8T



SERIES	END 1 CONNECTOR	END 2 CONNECTOR	OVERALL LENGTH
RFC6T* = 12G-SDI, Belden 4694R Cable RFC8T* = 12G-SDI, Belden 4855R Cable RFA6T = RG 6 Cable RFB6T = Belden 1694A Cable RFB8T = Belden 1855A Cable		-H4SP3 = 75 Ω High-Density BNC Straight Plug	-"XXXX" = Overall Length in millimeters -0300 (300 mm) 11.81" minimum

ALSO AVAILABLE

75 Ω: DIN 1.0/2.3, BNC = RFB6T, RFA6T, RFC6T
 75 Ω: DIN 1.0/2.3 = RFB8T, RFC8T

*Designed to meet SMPTE 2082 12G-SDI specifications.

HIGH-DENSITY BNC Board Connectors

HDBNC-TH, HDBNC-EM, HDBNC-BH, HDBNC-BM

Cable Mates:

RFA6T, RFB6T, RFB8T, RFC6T, RFC8T

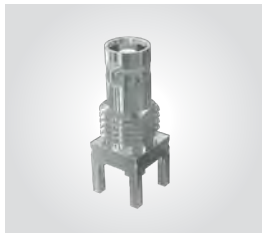

HDBNC	GENDER	TYPE	PLATING	ORIENTATION	TERMINATION	PACKAGING
	-J = Jack	-P = PCB Mount	-GN = 10 μ" (0.25 μm) Gold contact, 100 μ" (2.54 μm) Nickel shell	-ST = Straight -RA = Right-angle	-BH1 = Through-hole -BH2 = Through-hole (2.36 mm) .093" PCB (-RA only) -BM1D = Die Cast Bulkhead Mixed Technology for (1.60 mm) .062" PCB (-RA only) -BM2D = Die Cast Bulkhead Mixed Technology for (3.18 mm) .125" PCB (-RA only) -EM1 = Edge Mount (-ST only) -TH1 = Through-hole, Three Legs (-ST only)	Leave blank for individually bagged. -B Bulk packaged (-BHX only)
				 -RA-BH2	 -ST-EM1	
				 -RA-BM1D & -BM2D (BALANCED FOR PICK-AND-PLACE)	 -ST-BH1	 -ST-TH1

Notes:

Designed to meet SMPTE 2082 12G-SDI specifications.

Additional plating options available on Cable Assemblies, Cable Connectors and Board Connectors. Contact RFGroup@samtec.com

HIGH-DENSITY BNC Cable Connectors

HDBNC-CA

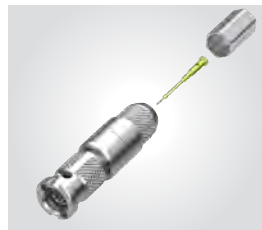

CONNECTORS FOR INDUSTRY STANDARD CABLES	
HDBNC-P-C-GN-ST-CA6	RG 6, Belden 1694A or Belden 4694R Cable
HDBNC-P-C-GN-ST-CA8	Belden 1855A or Belden 4855R Cable

Add "-B" to the end of the part number for bulk packaging (100 max.)

P-C = Cable Plug

GN = Plating (10 μ" Gold on contact, Nickel on outer contact & shell)

ST = Straight

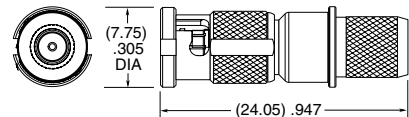

-CA6

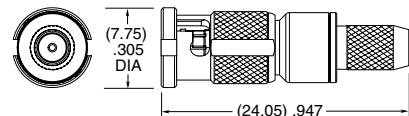

-CA8

Supplied with pins and ferrules. See website with dimensions.

Designed to meet SMPTE 2082 12G-SDI specifications.

75 Ω DIN 1.0/2.3 TO 12 GHz

DIN Cable Assemblies

RFA6T, RFB6T, RF179, RFB8T, RFC6T, RFC8T



SERIES	END 1 CONNECTOR	END 2 CONNECTOR	OVERALL LENGTH
RFC6T* = 12G-SDI, Belden 4694R Cable RFC8T* = 12G-SDI, Belden 4855R Cable RFA6T = RG 6 Cable RFB6T = Belden 1694A Cable RF179 = RG 179 Cable RFB8T = Belden 1855A Cable	-78SP4 = 75 Ω DIN Straight Plug		-"XXXX" = Overall length in millimeters -0100 (100 mm) 3.94" minimum (RF179) -0300 (300 mm) 11.81" minimum (RFA6T, RFB6T, RFB8T, RFC6T, RFC8T)
ALSO AVAILABLE 75 Ω: HDBNC, BNC = RFB6T, RFA6T, RFC6T 75 Ω: BNC, SMB, MCX, MMCX = RF179 75 Ω: HDBNC = RFB8T, RFC8T			

*Designed to meet SMPTE 2082 12G-SDI specifications.

DIN Board Connectors

DIN7A-TH, DIN7A-BH

Cable Mates:

RFA6T, RFB6T, RF179, RFB8T, RFC6T, RFC8T, GRF7H-C



DIN7A	GENDER	TYPE	PLATING	ORIENTATION	TERMINATION	PACKAGING
	-J = Jack	-P = PCB Mount	-GF = 10 μ" (0.25 μm) Gold center contact, 3 μ" (0.08 μm) Gold outer contact, 100 μ" (2.54 μm) Nickel body -RA only)	-ST = Straight (-TH1 only) -RA = Right-angle (-BH1 only)	-TH1 = Through-hole (-ST only) -BH1 = Bulkhead Through-hole (-RA only)	Leave blank for individually bagged. -B = Bulk packaged (-BH1 only)
				NUT		-RA-BH1

Notes:

Contact RFGroup@samtec.com for 12G-SDI PCB mount launch characteristics.

Designed to meet SMPTE 2082 12G-SDI specifications.

Additional plating options available on Cable Assemblies, Cable Connectors and Board Connectors. Contact RFGroup@samtec.com

DIN Cable Connectors

DIN7A-CA



CONNECTORS FOR INDUSTRY STANDARD CABLES	
DIN7A-PP-C-GF-ST-CA3	RG 179
DIN7A-PP-C-GF-ST-CA6	*RG 6, Belden 1694A or Belden 4694R Cable
DIN7A-PP-C-GF-ST-CA8	*Belden 1855A or Belden 4855R Cable

Add "-B" to the end of the part number for bulk packaging (100 max.)

*Designed to meet SMPTE 2082 12G-SDI specifications.

PP-C = Push Pull Plug Cable

GF = Plating (10 μ" Gold on center contact, Flash Gold on outer contact, Nickel on Shell)

ST = Straight

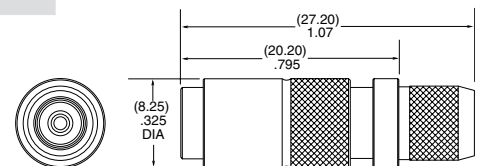

-CA6

Supplied with pins and ferrules. See website for dimensions

75 Ω SMB TO 4 GHz

SMB Cable Connectors RF179



SERIES	END 1 CONNECTOR	END 2 CONNECTOR	OVERALL LENGTH
--------	-----------------	-----------------	----------------

RF179
= RG 179 Cable

-77SP1
= 75 Ω SMB Straight Plug

-77RP1
= 75 Ω SMB Right-angle Plug

-“XXXX”
= Overall Length in millimeters
-0100 (100 mm) 3.94" minimum

ALSO AVAILABLE

75 Ω: DIN 1.0/2.3, BNC, MCX, MMCX = RF179

SMB Cable Connectors SMB7H-TH, SMB7H-EM

Cable Mates:
RF179, GRF7H-C

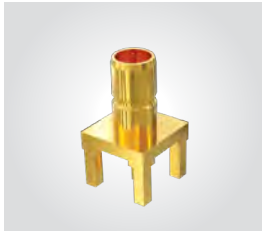

SMB7H	GENDER	TYPE	PLATING	ORIENTATION	TERMINATION
-------	--------	------	---------	-------------	-------------

-J
= Jack

-P
= PCB Mount

-H
= 30 μ" (0.76 μm) Gold center contact,
3 μ" (0.08 μm) Gold outer contact

-ST
= Straight

-RA
= Right-angle

-TH1
= Through-hole ((0.90 mm) .035" DIA Signal Pin)

-TH2
= Through-hole ((0.51 mm) .020" DIA Signal Pin) (-ST only)

-EM1
= Edge Mount (-ST only)

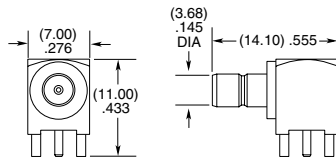

-RA-TH1

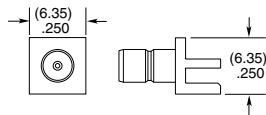

-ST-EM1

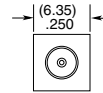

-ST-TH1 & -ST-TH2

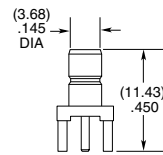

Note:
Additional plating options available on Cable Assemblies, Cable Connectors and Board Connectors. Contact RFGroup@samtec.com

SMB Cable Connectors SMB7H-CA



CONNECTORS FOR INDUSTRY STANDARD CABLES	
SMB7H-P-C-H-ST-CA3	RG 179 Cable
SMB7H-P-C-HF-RA-CA3	RG 179 Cable

P-C = Cable Plug
H or HF = Plating (30 μ" Gold center contact, 3 μ" Gold outer contact)
ST = Straight
RA = Right-angle

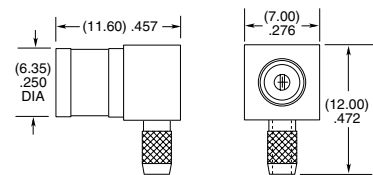

-P-RA

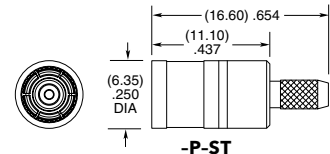

-P-ST

Supplied with pins and ferrules.
See website for dimensions

ORIGINAL SOLUTIONS LOW FREQUENCY RF

SHIELDED TWISTED PAIR SYSTEM

- 100 Ω differential pair
- 28 AWG shielded twisted pair cable assembly
- High-reliability BeCu contacts
- 1/4-turn bayonet lock

DC TO
4
GHz

GANGED MICRO-MINI SYSTEMS

- 50 Ω & 75 Ω board stacking and cable assemblies
- High-performance rugged contacts
- Variety of End 2 connectors (GRF1H-C, GRF7H-C Series)

DC TO
6
GHz

ISORATE® SYSTEMS

- 50 Ω board stacking and cable assemblies
- Isolated signal systems for 90 percent performance of traditional RF at 50 percent of the cost

DC TO
9.5
GHz

MINI & MICRO-MINI INTERCONNECTS

- 75 Ω impedance (MMCX7 & MCX7 Series)
- Higher extraction forces (MMCXV Series)
- Not intermateable with standard MMCX, MCX

DC TO
6
GHz

HIGH-CYCLE U.FL CABLE PLUG

- 500 cycle U.FL compatible plug (HMHF1 Series)
- .047" DIA low-loss flexible cable (RF047-A Series)

DC TO
10
GHz

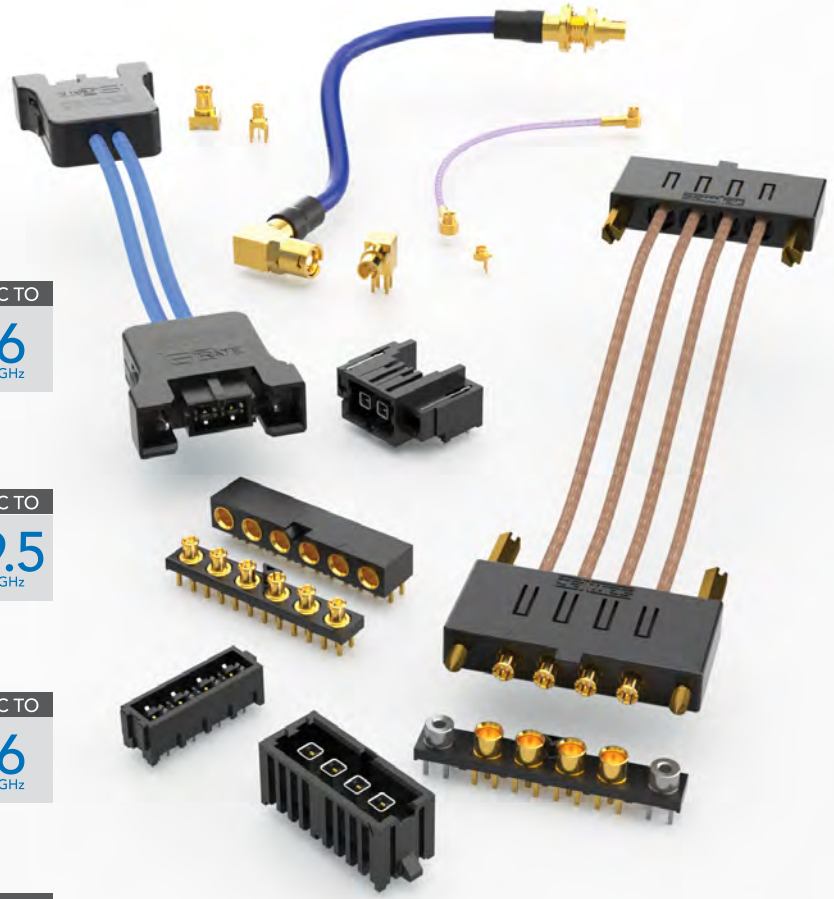

High Frequency Original RF Solutions Available.
See page 155

CABLE SOLUTIONS

SERIES	C28S/CJT	GRF1-C/GRF7-C	GRF1H-C/GRF7H-C	RF047-A	IJ5C/IJ5H
Application	Shielded Twisted Pair	50 Ω & 75 Ω Micro-Mini Ganged	50 Ω & 75 Ω Micro-Mini Hybrid Ganged	50 Ω .047 DIA Flexible Cable	50 Ω IsoRate®
URL	samtec.com?C28S samtec.com?CJT-BH samtec.com?CJT-TH	samtec.com?GRF1-C samtec.com?GRF7-C	samtec.com?GRF1H-C samtec.com?GRF7H-C	samtec.com?RF047-A	samtec.com?IJ5C samtec.com?IJ5H

BOARD-TO-BOARD SOLUTIONS

SERIES	GRF1-P/GRF1-J	GRF7-P/GRF7-J	MMCX7	MCX7	MMCXV	IJ5/IP5
Application	50 Ω Micro-Mini Ganged	75 Ω Micro-Mini Ganged	75 Ω Mini and Micro-Mini Interconnects		High-Vibration Micro-Mini	50 Ω IsoRate®
URL	samtec.com?GRF1-P samtec.com?GRF1-J	samtec.com?GRF7-P samtec.com?GRF7-J	samtec.com?MMCX7-TH samtec.com?MMCX7-CA	samtec.com?MCX7 samtec.com?MCX7-CA	samtec.com?MMCXV-TH samtec.com?MMCXV-EM samtec.com?MMCXV-CA	samtec.com?IJ5 samtec.com?IP5

RF DESIGN, DEVELOPMENT & TECHNICAL SUPPORT

SIGNAL INTEGRITY & RF DESIGN EXPERTISE & SUPPORT

- Launch optimization & design services
- Simulation
- Prototyping
- Physical test and measurement verification
- Full channel analysis, system support
- Application specific design and development assistance

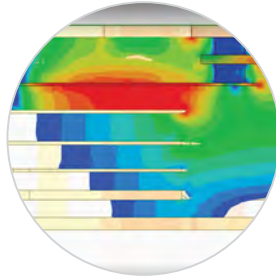

E-field Simulation

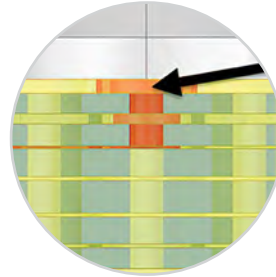

3D Modeling

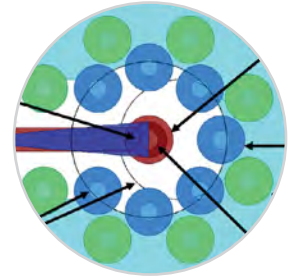

Launch Optimization

TECHNICAL RESOURCES

Samtec's Technical Library contains white papers, application/technical notes, published papers, webinars and presentations on high-performance system design. These resources underscore how Samtec supports interconnectivity needs across multiple industries, applications, performance requirements and operating environments.

WHITE PAPERS

- Wideband RF Launches
- Impacts of Solder Reflow on RF Connectors
- Millimeter Wave Design
- Visit [samtec.com/tech-library](https://www.samtec.com/tech-library)

TECHNICAL REPORTS

- Precision Alignment in Test and Measurement Applications: [samtec.com/alignment](https://www.samtec.com/alignment)

PRESENTATIONS & WEBINARS

- Understanding Transmission Line Discontinuities: [samtec.com/system-impedance](https://www.samtec.com/system-impedance)
- Precision RF Connector PCB Launches for 224 Gbps Devices: [samtec.com/rf-launches-224](https://www.samtec.com/rf-launches-224)

CUSTOM SOLUTIONS & QUICK-TURN MODIFICATIONS

Samtec's fully vertically integrated business model enables the flexibility to quickly and efficiently identify and/or develop innovative, application-specific interconnect solutions to meet a variety of demands in digital/analog systems.

- Board termination types
- Tin dipping capabilities
- Heat-shrink tubing
- Alternate platings
- Pick & place machine designs
- Automated assembly counterweights
- Contact RFGroup@samtec.com to discuss your system requirements

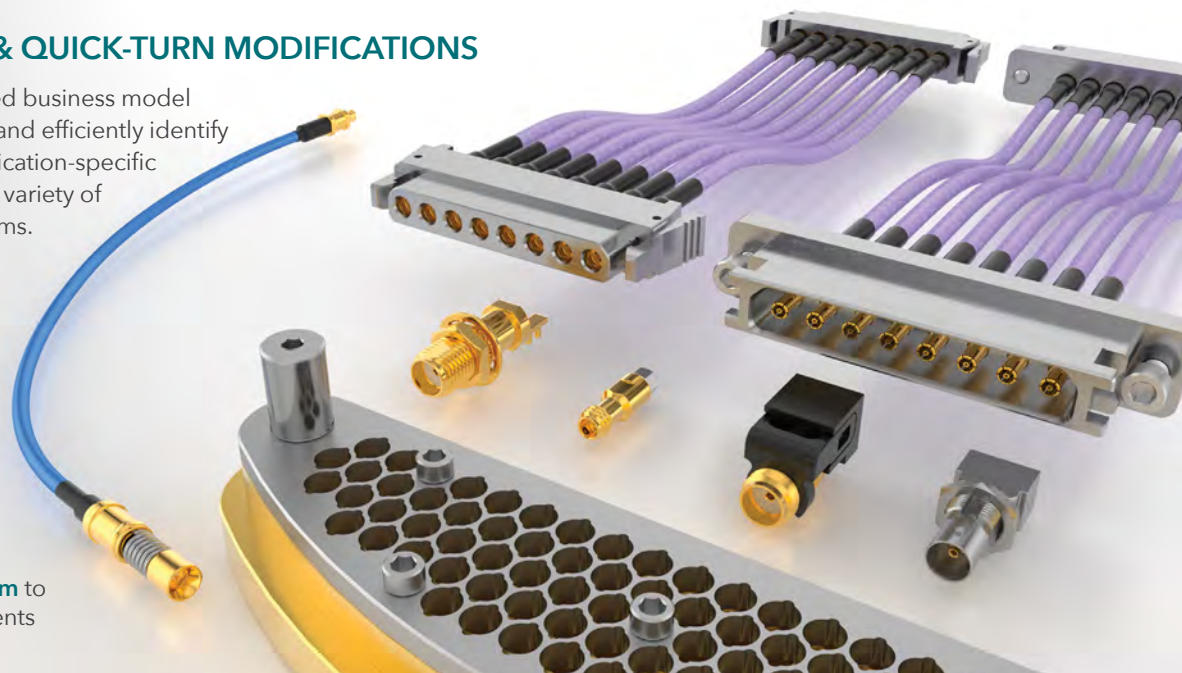

ULTRA RUGGED SOLUTIONS

EXTREME HIGH MATING CYCLES • RUGGED MIL-DTL MATERIALS • SEVERE ENVIRONMENT TESTING

199 RUGGED POWER I/O SYSTEMS
(B1SD(T)/P1PD(T)/P1M, B1SM/P1SM)



URSA I/O
ULTRA RUGGED CABLE SYSTEM

199 38999 RUGGED I/O SYSTEMS
(NVA3E/NVA3P)



NOVARAY I/O

200 SPACE MID-BOARD OPTICAL TRANSCEIVERS
(CSSO)



FIREHAWK

200 VITA™ 90 VNX+™ SOLUTIONS
(SEARAY™, VBM, RUGGED OPTICS)



VNX+

200 EXTREME ENVIRONMENT & EXTENDED TEMP OPTICS
(ETMO, ETUO, UEC5/UCC8)

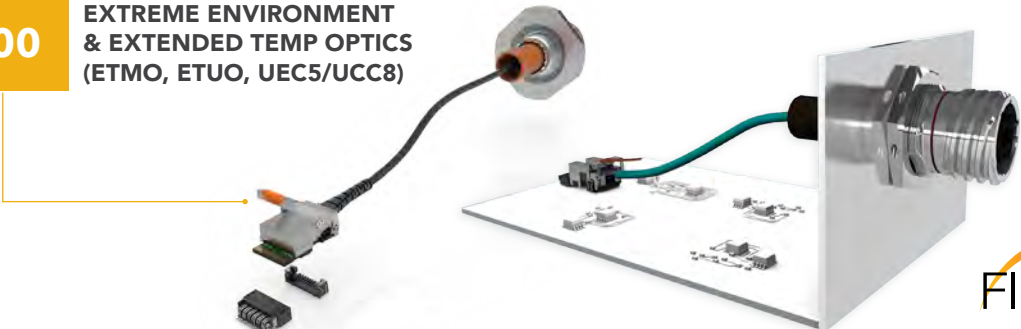

FIREFLY

ULTRA RUGGED SOLUTIONS

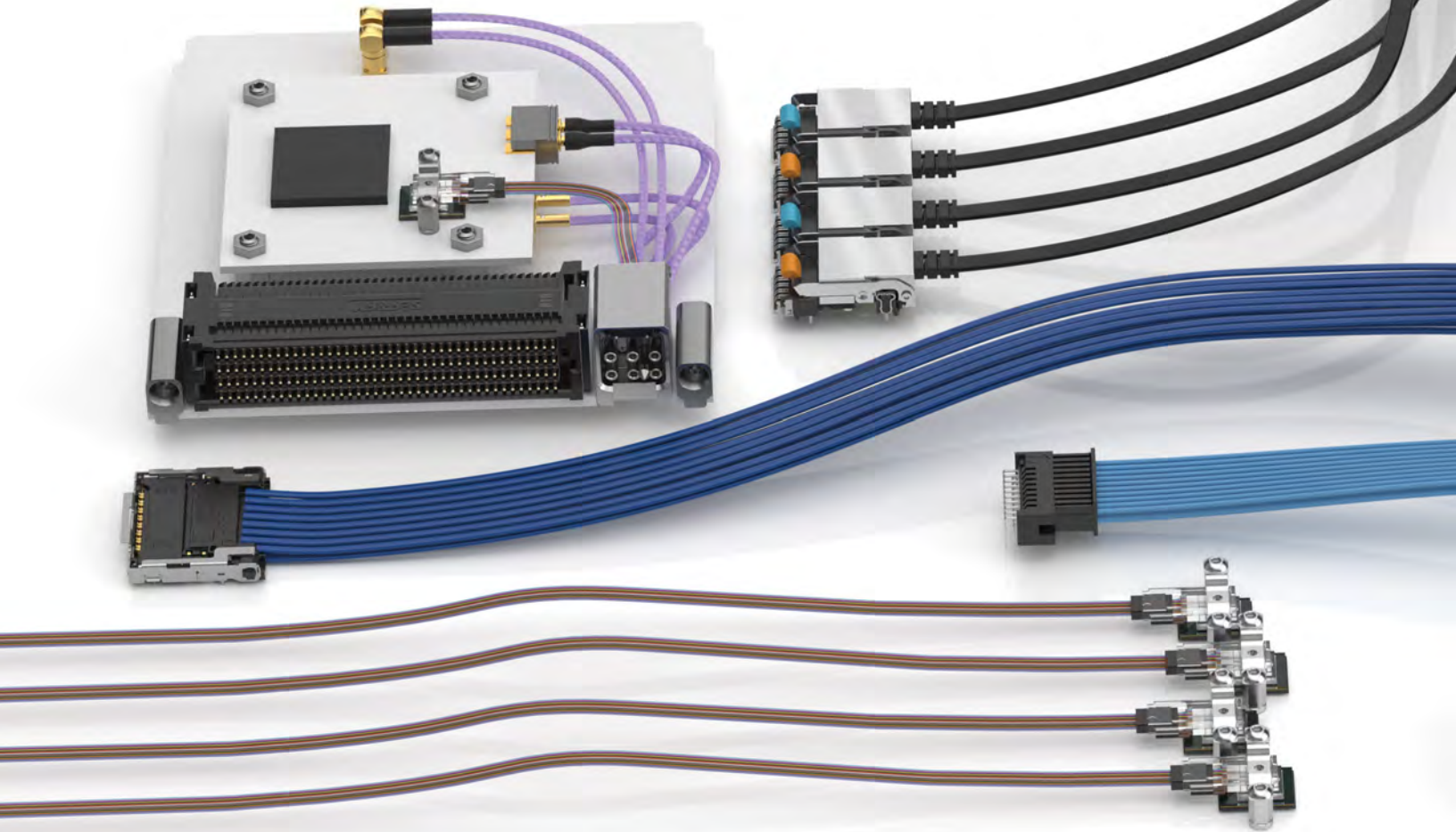

Samtec's ultra rugged solutions provide reliability and flexibility in small form factors for extreme/harsh environments. From rugged I/O cable assemblies, sealed & compact optics, and VITA™ 90 VNX+™ modules to ultra rugged hardware and high-temp coatings, these solutions are ideal for military, aerospace, submersible and other harsh environment applications. Many ultra rugged offerings are available now with a robust roadmap to meet or exceed requirements for harsh environment applications and industries.

For design flexibility and cost optimization, Samtec's Severe Environment Testing (SET) qualified products are Commercial-Off-the-Shelf (COTS) and modified COTS to get solutions to market faster. See page 202-203 or visit samtec.com/set for more information.



VITA/VNX/VNX+ are all respective trademarks of VITA

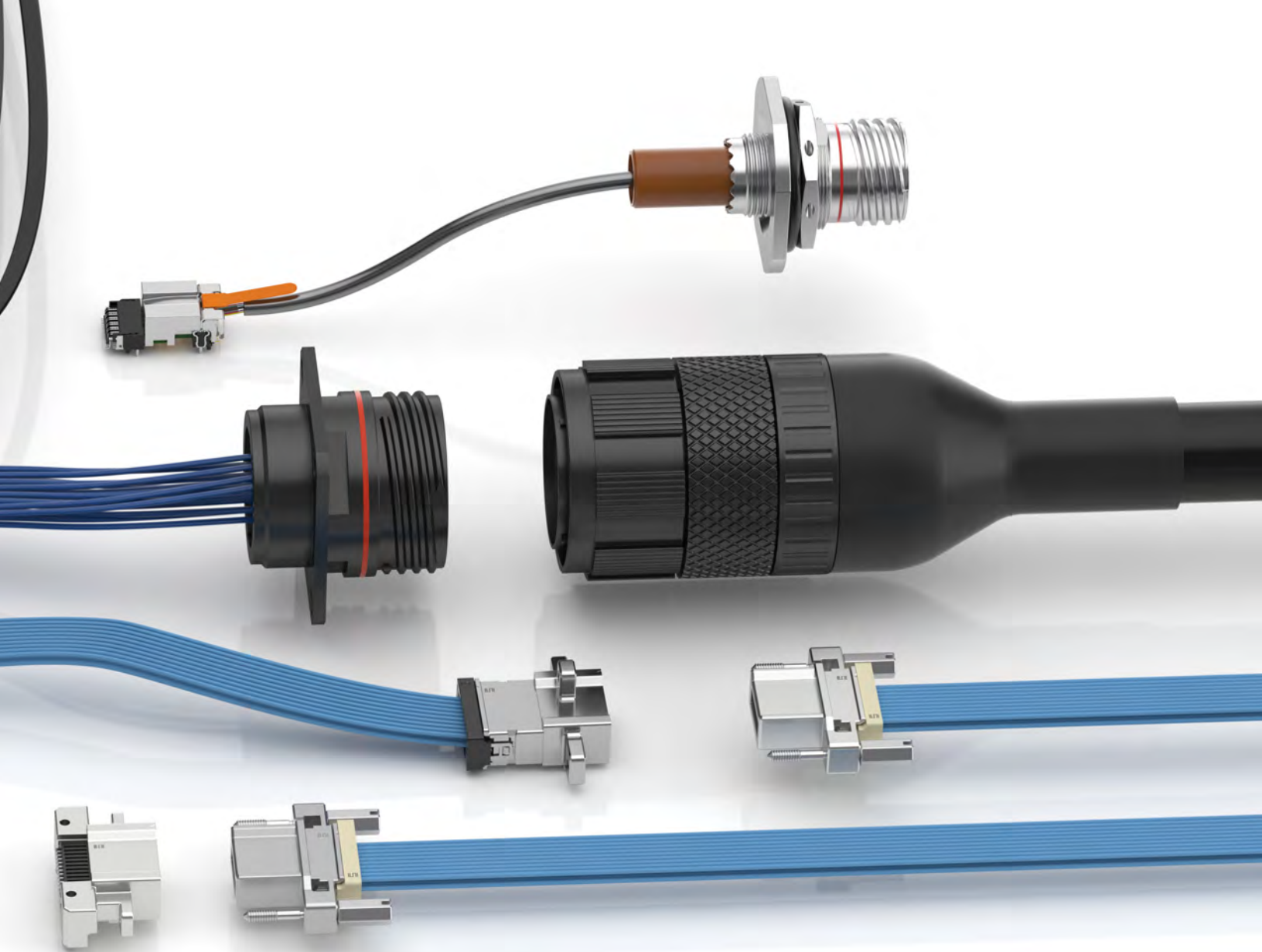

RUGGED I/O SYSTEMS

- Hyper Claw™ contacts with four points of contact for a reliable connection and high mating cycles
- Variety of high-speed, RF and power contacts in 1 to 5 bank configurations
- EMI shielding limits signal degradation and optimizes performance
- Series: B1SD(T)/P1PD(T)/P1M, B1SM/P1SM
- See page 226-231 for more information
- samtec.com/ursa



38999 RUGGED I/O SYSTEMS

- High data rate cable system in a rugged 38999 shell
- Salt fog resistant to 48 hours; IP67 for dust and waterproof sealing
- Threaded cable-to-panel design
- High-density 16 and 32 pair
- Series: NVA3E/NVA3P
- See page 107 for more information
- samtec.com/novaray-io





EXTREME ENVIRONMENT MID-BOARD OPTICAL TRANSCEIVERS

- Sealed and parylene-coated for exposed military and aerospace applications
- Other rugged environment capabilities include salt fog resistance and tin whisker mitigation
- Extended temp range of -40 °C to +85 °C
- Series: ETMO/UEC5/UCC8
- See page 139 for more information
- samtec.com/firefly

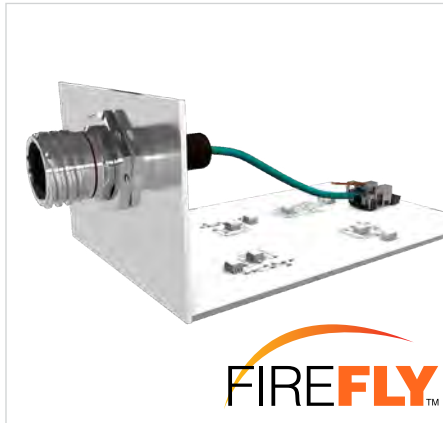

EXTENDED TEMP MID-BOARD OPTICAL TRANSCEIVERS

- Extended temperature range from -40 °C to +85 °C
- x4 and x12 designs to 25 Gbps per lane performance
- Samtec's Extended Temp FireFly™ optical with Amphenol® Aerospace bulkhead interconnects
- Small footprint allows for increased density
- Series: ETUO/UEC5/UCC8
- See page 138 for more information
- samtec.com/firefly



VITA™ 90 VNX+™ SOLUTIONS

- RF backplane system to support 110 GHz with high-density size 20 and 16 coaxial contacts
- Rugged blind mate solution
- Configured with SEARAY™ right-angle array and rugged optics
- SWaP-C reductions make this ideal for military and aerospace applications
- COTS or modified COTS solution for cost and time flexibility
- See page 344-345 for more information
- samtec.com/vnx-plus

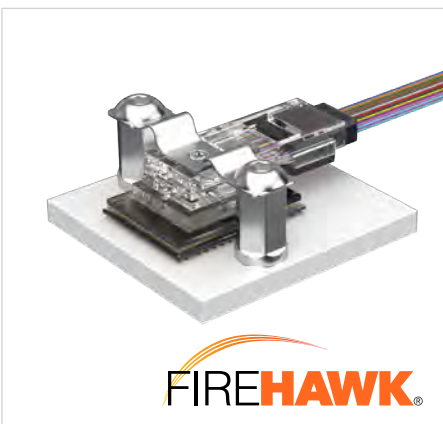

SPACE MID-BOARD OPTICAL TRANSCEIVERS

- FireHawk® is the smallest optical transceiver in the industry – 10 x 7.7 x 4.4 mm, less than 0.4 grams
- Extreme performance up to 40 Gbps aggregate
- Rugged BGA attach withstands high shock and vibration
- Radiation tolerant design for space/satellites
- Series: CSSO
- See page 145 for more information
- samtec.com/firehawk

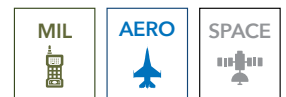



ULTRA RUGGED HARDWARE

- Guide post standoffs (GPSO) allow for .035" of initial misalignment
- 303 stainless steel with MIL-C-13924 black oxide finish
- Jack screw precision standoffs (JSO) reduce the risk of component damage
- Standoffs (SO) with precision machined tolerances (+/- .002" (0.05 mm))
- Guide post with built-in grounding pin for first mate/last break applications
- See pages 34-36 for more information
- samtec.com/hardware

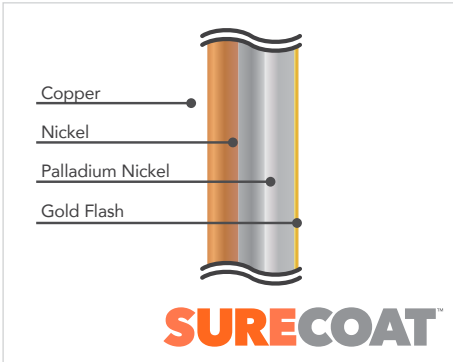

HIGH-RELIABILITY PLATING

- 30 μ" palladium nickel plating with gold flash for high-temp, high-cycle applications
- Qualified up to 150 °C ambient
- Available on SEARAY™ 1.27 mm pitch high-density arrays and Edge Rate® 0.80 mm pitch high-speed strips to 5,000 cycles
- Product Roadmap includes SEARAY™ 0.80 mm, AcceleRate® HP, LP Array™ and Generate® 0.80 mm
- Ideal for ATE applications

RUGGEDIZING OPTIONS



LATCHING

Manually activated latches increase unmating force by up to 200%

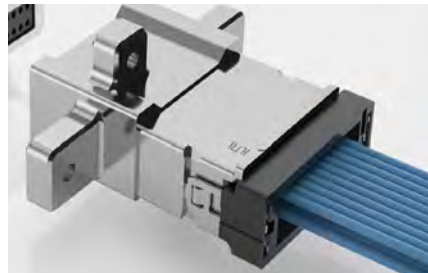

STRAIN RELIEF

Helps protect against damage caused by frequent movement, strain or stress

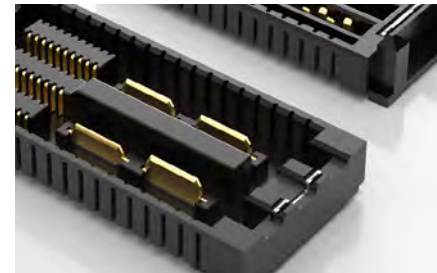

WELD TABS

Significantly increases shear resistance of connector to PCB



GUIDE POSTS

Easy and secure mating



SHIELDING

360° shielding reduces EMI

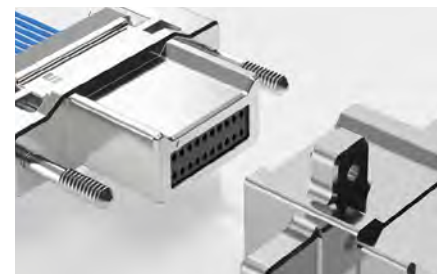

SCREW DOWNS / PANEL SCREWS

Secure mechanical attachment to the board or panel

ULTRA RUGGED TESTING

SEVERE ENVIRONMENT TESTING (SET) | SAMTEC.COM/SET



Additional testing beyond typical industry standards for performance confidence in military, space, automotive, industrial and other extreme environment applications. Qualified products are Commercial Off-the-Shelf (COTS) and modified COTS for quick-to-market solutions. Visit samtec.com/SET or contact SET@samtec.com for more information and test results.

VITA™ STANDARD		MEETS	EXCEEDS
47.1	Module Insertions	✓	
	Operating Shock Class OS2	✓	
	Vibration Class VS3	✓	
	Electrostatic Discharge Resistance	✓	
	Temperature Cycling Class C4		✓
	Non-Operating Temperature Class C4		✓
	Altitude for DWV		✓
47.3	Humidity	✓	

QUALIFIED SERIES	PITCH	TYPE
LSHM	0.50 mm	Razor Beam™ Hermaphroditic Strips
ERF8/ERM8	0.80 mm	Edge Rate® Rugged, High-Speed Strips
SEAF8/SEAM8	0.80 mm	SEARAY™ 0.80 Ultra-High Density Arrays
B1SDT/P1M	1.00 mm	URSA® I/O Ultra Rugged Cable System
SFM/TFM/SFSDT	1.27 mm	Rugged Tiger Eye™ Connectors
SEAF/SEAM	1.27 mm	SEARAY™ High-Density Arrays
FTSH/CLP	.050"	Flexible Stacking Header & Socket
S2M/T2M	2.00 mm	Tiger Eye™ Micro Rugged System
UMPS/UMPT	2.00 mm	mPOWER® Ultra Micro Power Connectors
SSM/TSM	.100"	Square Post Header & Socket



LOT SCREEN TESTING

This program provides assurance for upscreening board-to-board interconnects for mission critical applications. Lot Screen Testing and Qualification Conformance Inspection (QCI) are both modeled after MIL-DTL-55302 and parallel EIA-364 standards. Contact map@samtec.com or visit samtec.com/mil-aero for details.

NASA-ALIGNED SOLUTIONS

SET products are approved for NASA Class D missions including LEO satellites, Small-Sats, CubeSats and other space exploration applications. NASA outgassing data is used to determine if certain products meet ASTM E595-77/84/90 requirements. Visit outgassing.nasa.gov.

TESTING OPTIONS	LOT SCREEN TESTING	QCI
Visual & Mechanical Inspection	✓	✓
Mating/Unmating Forces	✓	✓
Low Level Contact Resistance	✓	✓
Insulation Resistance	✓ (Pin-to-Pin & Row-to-Row)	✓ (Pin-to-Pin, Row-to-Row & Closest Metallic Hardware)
Dielectric Withstanding Voltage	✓ (Sea Level)	✓ (Sea Level & High Altitude)
Solderability	✓	✓
Contact Resistance	✓	✓
Mechanical Shock		✓
Random Vibration		✓
Extended Life		✓ (Plating Thickness Verification, Mating Cycle, Thermal Shock & Humidity)
Workmanship		✓

EXTENDED LIFE PRODUCT™ (E.L.P.™) | SAMTEC.COM/ELP

E.L.P.™ products are tested to rigorous standards, which evaluate contact resistance in simulated storage and field conditions.

- 10 year Mixed Flowing Gas (MFG)
- High Mating Cycles (250 to 2,500)
- Certain plating and/or contact options will apply

For complete details about Samtec's E.L.P.™ program, a list of qualifying products and test results, please visit samtec.com/ELP or email the Customer Engineering Support Group at ASG@samtec.com

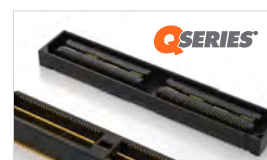

DESIGN QUALIFICATION TESTING (DQT)

All Samtec series undergo Design Qualification Testing (DQT), which includes:

- Gas Tight
- Normal Force
- Thermal Aging
- Mating/Unmating/Durability
- IR/DWV
- Current Carrying Capacity (CCC)
- Mechanical Shock/Random Vibration/LLCR
- Mechanical Shock/Random Vibration/Event Detection

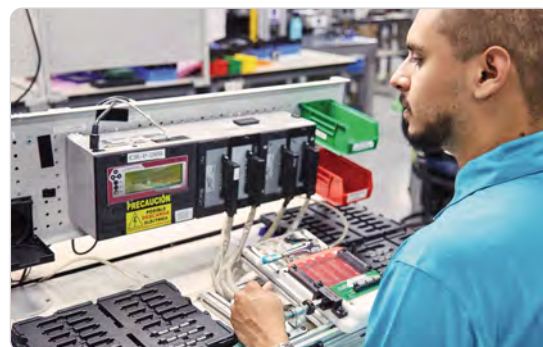

TESTING REFERENCE CHART

TEST	SET	E.L.P.™	DQT
Gas Tight	✓*	✓*	✓
Normal Force	✓*	✓*	✓
Thermal Aging	✓*	✓*	✓
Mating / Unmating / Durability (240 Hrs)	✓ (100% RH, 250 Cycles)	✓* (90-98% RH, 100 Cycles)	✓ (90-98% RH, 100 Cycles)
IR / DWV	✓ (At Altitude of 70,000 Feet)	✓*	✓
CCC	✓*	✓*	✓
Mechanical Shock / Random Vibration / LLCR & Nanosecond Event Detection	✓ (40 G Peak, 11 ms, Half Sine & 12gRMS, 5 - 2,000 Hz, 1 Hr / Axis)	✓* (100 G Peak, 6 ms, Half Sine & 7.56gRMS Avg, 2 Hr / Axis)	✓ (100 G Peak, 6 ms, Half Sine & 7.56gRMS Avg, 2 Hr / Axis)
Temperature Cycling (500 Cycles)	✓	N/A	N/A
Non-Operating Class Temperature	✓	N/A	N/A
Electrostatic Discharge (ESD)	✓	N/A	N/A
10 Year MFG (Mixed Flowing Gas)	N/A	✓	N/A
Mating Cycles (250 to 2,500)	N/A	✓	N/A

* Completed as part of initial Design Qualification Testing (DQT). E.L.P.™ and SET testing are performed in addition to DQT.

POWER SERVICES

POWER INTEGRITY SERVICES

- Standard power test data, including current carrying capacity, working voltage, voltage drop and resistance, creepage and clearance, is available for select power systems
- Current Cycling Test Data, which demonstrates connector performance in realistic and common applications, is available for select series
- Power Integrity Guidelines are based on test data and proven design parameters, designed to help in connector selection and PCB design maximization
- Power Integrity Certified products undergo testing and additional requirements unique to Samtec. Products must pass Current Cycling Test EIA 365-55, have current carrying capacity, resistance vs. number of contacts data available and Power Integrity Guidelines developed
- Visit samtec.com/powerintegrity to learn more

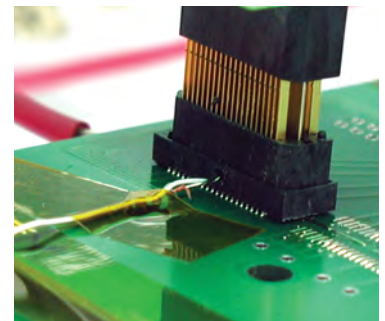
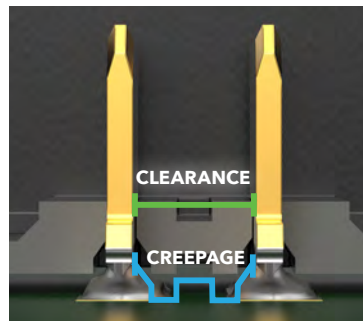
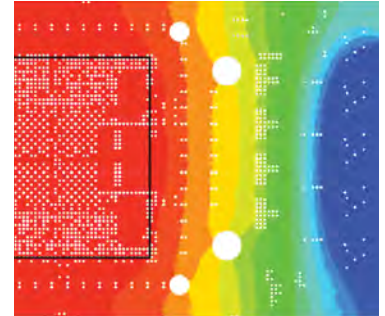

POWER ARCHITECTURE, SYSTEM DESIGN & ROUTING SERVICES

Samtec provides complete support and strategies for the optimization of system power architectures. Visit samtec.com/sig for more information.

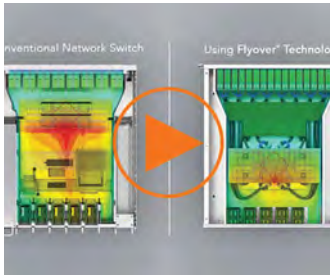

System Power Architectures & Design Solutions

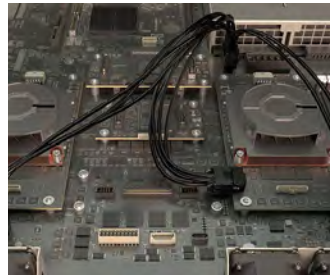

Reference Routing Development for Application-Specific Solutions

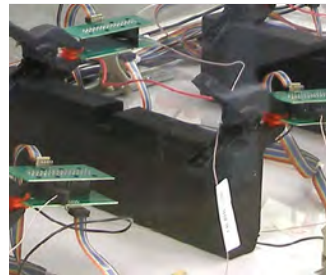

Safety and Reliability Design Assurance

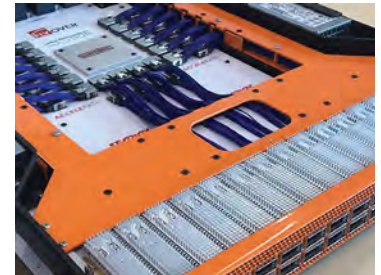

Recommendations for Customer-Specific Requirements

INTERACTIVE POWER CHART

Samtec offers power simulation that can calculate temperature increase in the connector area, in real time. Find this tool on samtec.com when searching a product for your specific application. Contact RuggedPower@samtec.com for assistance.



HIGH POWER SYSTEMS

UP TO 60 AMPS • ULTRA MICRO POWER • POWER/SIGNAL COMBINATIONS

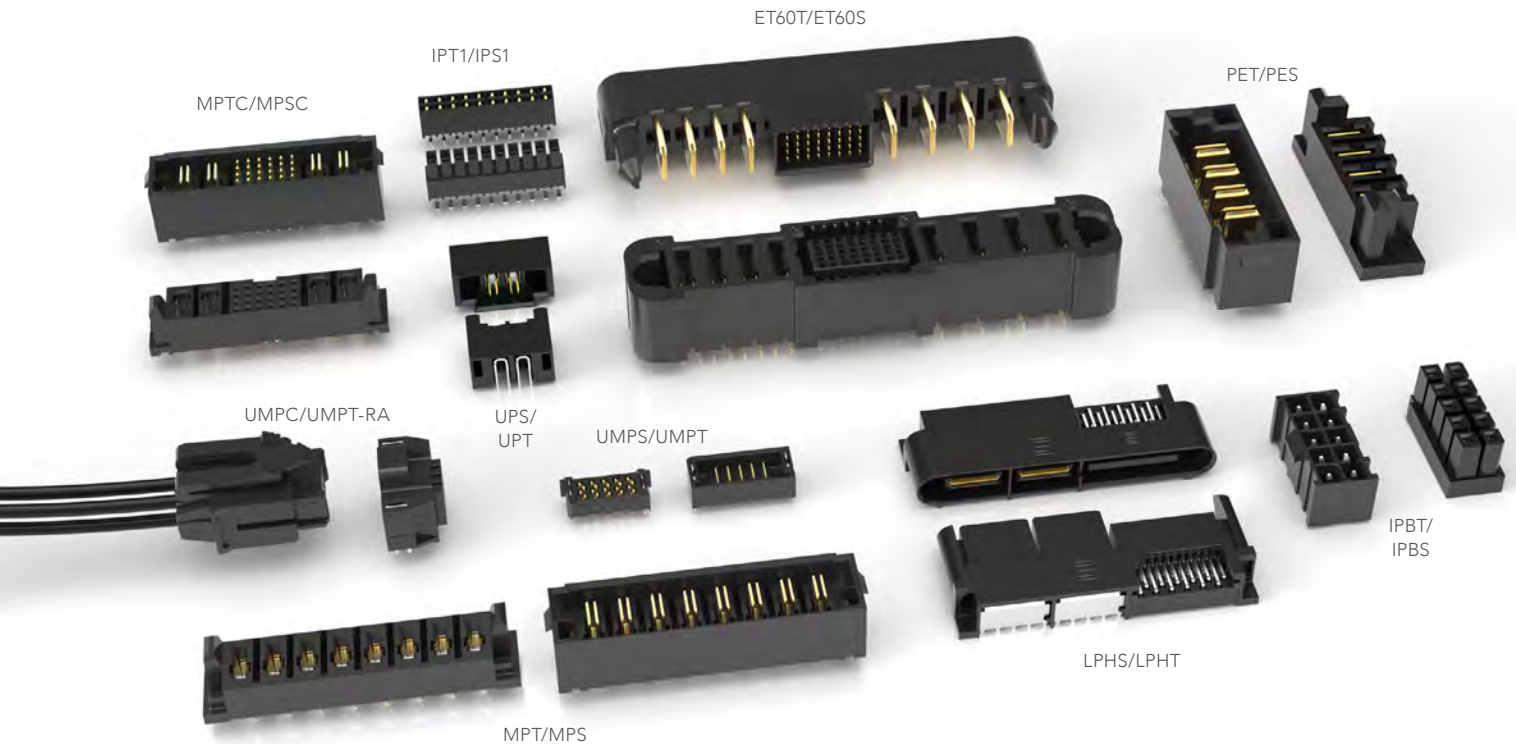

206-211

mPOWER® ULTRA MICRO POWER SYSTEMS

Socket & Terminal Board Connectors (UMPS, UMPT)	206-208
Cable-to-Board Assemblies & Components (UMPC(T), IMPC, CC489)	209
Cable-to-Cable Panel Mount Assemblies & Components (UMPE(T), UMPI(T), IMPE, IMPC, TC146, CC489) .	210-211

212-221

FLEX POWER SYSTEMS

EXTreme LPHPower™ Terminals and Sockets (LPHT, LPHS)	212-213
EXTreme Ten60Power™ Terminals and Sockets (ET60T, ET60S)	214-215
PowerStrip™/20 Headers & Sockets (UPS, UPT, UPPT)	216-217
PowerStrip™/30 Headers & Sockets (MPT, MPS, MPTC, MPSC)	218-219
PowerStrip™/40 Headers & Sockets (PET, PES, PETC, PES)	220-221

222-224

RUGGED POWER SYSTEMS

Mini Mate® Terminals & Sockets (IPT1, IPS1)	223
Power Mate® Terminals & Sockets (IPBT, IPBS)	224

ULTRA MICRO POWER SYSTEM

(2.00 mm) .0787" PITCH



MAX

18
A m p s

FEATURES & BENEFITS

- Board-to-board, cable-to-board and cable-to-cable
- Up to 18 A per blade (1 blade powered)
- Choice of 2 to 10 positions
- 5 mm to 20 mm stack heights; vertical and right-angle orientations
- Tin or 10 μ" Gold plated power blades; 30 μ" Gold plating available to meet specific regulations
- Optional weld tabs
- Mating cable assemblies with plastic top or metal side latching
- Severe Environment Testing qualified (UMPT/UMPS); aligns with MIL-DTL-55302. Visit samtec.com/set

KEY SPECIFICATIONS (UMPT/UMPS)

STACK HEIGHTS	INSULATOR MATERIAL	CONTACT MATERIAL	PLATING	OPERATING TEMP RANGE	VOLTAGE RATING	LEAD-FREE SOLDERABLE
5, 6, 7, 8, 9, 10, 11, 12, 13, 14, 15, 16, 18, 20 mm	Black LCP	Copper Alloy	Sn or Au over 50 μ" (1.27 μm) Ni	-55 °C to +105 °C with Tin -55 °C to +125 °C with Gold	460 VAC/ 651 VDC	Yes

CURRENT RATING (PER CONTACT)

PINS	UMPT/UMPS	
	-T	-L
1	17.8 A	17.5 A
2	15.5 A	16.3 A
3	13.5 A	13.9 A
4	12.9 A	13.2 A
10	9.8 A	8.9 A

Ratings are derated 20% with 30 °C rise to maximum allowable temperature.

CREEPAGE & CLEARANCE

UMPT/UMPS	
CREEPAGE	2.20 mm
CLEARANCE	1.65 mm

Selectively loading contacts achieves customer specific creepage and clearance requirements.

MAX
18
A m p s

ULTRA MICRO POWER SOCKET

UMPS	NO. OF POSITIONS	LEAD STYLE	PLATING OPTION	V	S	OPTION	"X"R
	-02, -03, -04, -05, -06, -07, -08, -09, -10	-03.5 = (03.5 mm) .138" -05.5 = (05.5 mm) .217" -07.5 = (07.5 mm) .295"	-L = 10 μ" (0.25 μm) Gold on contact, Matte Tin on tail -G = 10 μ" (0.25 μm) Gold on contact, Gold flash on tail -T = Matte Tin			-W = Weld Tab Through-hole (Leave blank for no weld tab)	-TR = Tape & Reel -FR = Full Reel Tape & Reel (must order max. quantity per reel; contact Samtec for quantity breaks)

UMPS
Board Mates:
UMPT
Standoffs:
GPSO

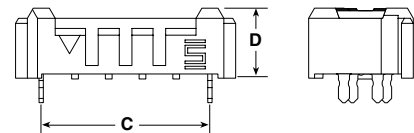
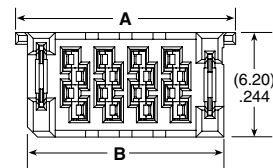

UMPS-04-03.5-X-V-S-W SHOWN

NO. OF POSITIONS	A	B	C
-02	(9.05) .356	(7.65) .301	(6.00) .236
-03	(11.05) .435	(9.65) .380	(8.00) .315
-04	(13.05) .514	(11.65) .459	(10.00) .394
-05	(15.05) .593	(13.65) .537	(12.00) .472
-06	(17.05) .671	(15.65) .616	(14.00) .551
-07	(19.05) .750	(17.65) .695	(16.00) .630
-08	(21.05) .829	(19.65) .774	(18.00) .709
-09	(23.05) .907	(21.65) .852	(20.00) .787
-10	(25.05) .986	(23.65) .931	(22.00) .866

LEAD STYLE	D
-03.5	(4.15) .163
-05.5	(6.15) .242
-07.5	(8.15) .321

UMPT LEAD STYLE	MATED HEIGHT		
	UMPS LEAD STYLE		
	-03.5	-05.5	-07.5
-01.5	(5.00) .197	(7.00) .276	(9.00) .354
-02.5	(6.00) .236	(8.00) .315	(10.00) .394
-06.5	(10.00) .394	(12.00) .472	(14.00) .551
-07.5	(11.00) .433	(13.00) .512	(15.00) .591
-12.5	(16.00) .630	(18.00) .709	(20.00) .787

UMPT/UMPS CURRENT RATING (PER CONTACT)

PINS	-T	-L
1	17.8 A	17.5 A
2	15.5 A	16.3 A
3	13.5 A	13.9 A
4	12.9 A	13.2 A
10	9.8 A	8.9 A

Ratings are derated 20% with 30 °C rise to maximum allowable temperature.

Notes:
Severe Environment
Testing qualified; aligns
with MIL-DTL-55302.
Visit samtec.com/set

Some lengths, styles and
options are non-standard,
non-returnable

View complete specifications at: samtec.com?UMPS

ULTRA MICRO POWER TERMINAL

UMPT	NO. OF POSITIONS	LEAD STYLE	PLATING OPTION	V	S	WELD TAB	LATCH OPTION	"X"R
UMPT Board Mates: -03, -04, -05, -06, -07, -08, -09, -10 UMPS Cable Mates: -09, -10 UMPC* (*UMPT requires -P or -M option for mating) Standoffs: GPSO	-02, -03, -04, -05, -06, -07, -08, -09, -10	-01.5 = (01.5 mm) .059" -02.5 = (02.5 mm) .098" -06.5 = (06.5 mm) .256" -07.5 = (07.5 mm) .295" -12.5 = (12.5 mm) .492" (-W option required)	-L = 10 μ" (0.25 μm) Gold on contact, Matte Tin on tail -G 10 μ" (0.25 μm) Gold on contact, Gold flash on tail -T = Matte Tin			(Leave blank for no weld tab) -W = Weld Tab Through-hole (Required for -12.5 lead style)	(Leave blank for no latch) (Only available on -02.5 lead style) (Weld tab required) -P = Plastic top latch -M = Metal side latches	-TR = Tape & Reel -FR = Full Reel Tape & Reel (must order max. quantity per reel; contact Samtec for quantity breaks)

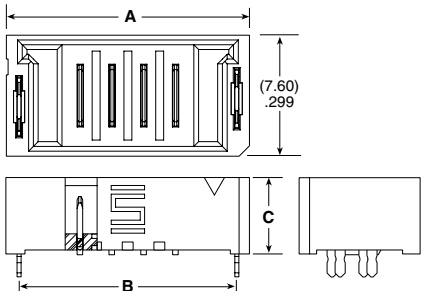



LEAD STYLE	C	NO. OF POSITIONS	
		A (-P & No latch)	B (-M latch)
-01.5	(4.80) .189	(11.30) .445	(9.70) .382
-02.5	(5.80) .228	(13.30) .524	(11.70) .460
-06.5	(9.55) .376	(15.30) .603	(13.70) .539
-07.5	(10.80) .425	(17.30) .681	(15.70) .618
-12.5	(15.80) .622	(19.30) .760	(17.70) .697
		(21.30) .839	(19.70) .776
		(23.30) .917	(21.70) .854
		(25.30) .996	(23.70) .933
		(27.30) 1.075	(25.70) 1.012
		(29.30) 1.154	(27.60) 1.087

UMPT-04-01.5-X-V-S-W SHOWN

Notes: Severe Environment Testing qualified; aligns with MIL-DTL-55302. Visit samtec.com/set
Some lengths, styles and options are non-standard, non-returnable. View complete specifications at: samtec.com?UMPT

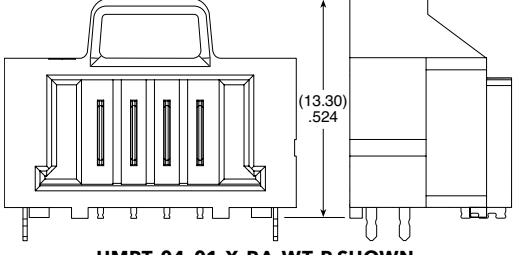
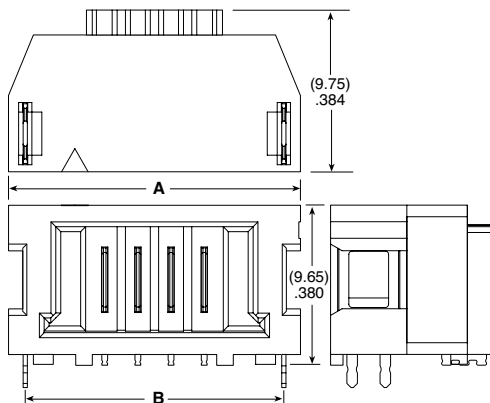
UMPT	NO. OF POSITIONS	01	PLATING OPTION	RA	WELD TAB	LATCH OPTION	"X"R
UMPT-RA Board Mates: -02, -03, -04, -05, -06, -07, -08, -09, -10 UMPS Cable Mates: -09, -10 UMPC* (*UMPT requires -P or -M option for mating)	-02, -03, -04, -05, -06, -07, -08, -09, -10		-L = 10 μ" (0.25 μm) Gold on contact, Matte Tin on tail -G 10 μ" (0.25 μm) Gold on contact, Gold flash on tail -T = Matte Tin		-WT = Weld Tab Through-hole	(Leave blank for no latch) -P = Plastic top latch -M = Metal side latches	-TR = Tape & Reel -FR = Full Reel Tape & Reel (must order max. quantity per reel; contact Samtec for quantity breaks)





NO. OF POSITIONS	A		B	
	(-P & No latch)	(-M latch)	(-P & No latch)	(-M latch)
-02	(13.60) .535	(11.10) .437	(11.55) .455	
-03	(15.60) .614	(13.10) .516	(13.55) .533	
-04	(17.60) .693	(15.10) .594	(15.55) .612	
-05	(19.60) .772	(17.10) .673	(17.55) .691	
-06	(21.60) .850	(19.10) .752	(19.55) .770	
-07	(23.60) .929	(21.10) .831	(21.55) .848	
-08	(25.60) 1.008	(23.10) .909	(23.55) .927	
-09	(27.60) 1.087	(25.10) .988	(25.55) 1.006	
-10	(29.60) 1.165	(27.10) 1.067	(27.55) 1.085	

UMPT-04-01-X-RA-WT-P SHOWN
UMPT-04-01-X-RA-WT-M SHOWN

Note: Some lengths, styles and options are non-standard, non-returnable. View complete specifications at: samtec.com?UMPT-RA

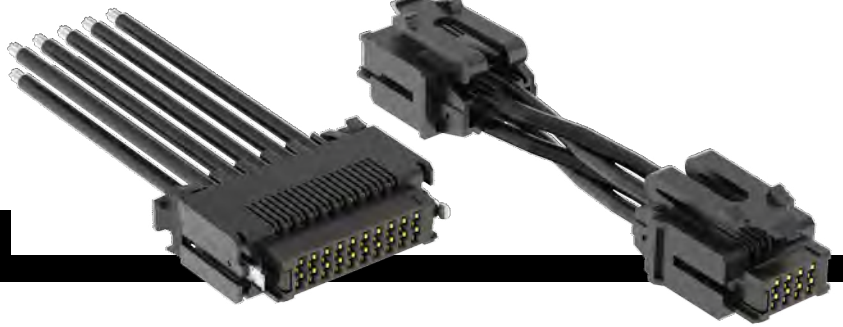
ULTRA MICRO POWER CABLE



SERIES	NO. OF POSITIONS	PLATING OPTION	WIRE GAUGE	LATCH OPTION	LENGTH	PINOUT
UMPC = Ultra Micro PVC Cable	-02, -03, -04, -05, -06, -07, -08, -09, -10	-L = 10 μ" (0.25 μm) Gold on contact, Tin on tail	-16 = 16 AWG	(Latching required)	-"XX.X" = Assembled Length in Inches	(Leave blank for Single ended)
UMPC(T) = Ultra Micro Blue *Teflon™ Fluoropolymer Cable		-T = Tin	-16C = Color Coded Cable (UMPC only)	-P = Plastic top latch	PVC Cable Single ended = (76.2 mm) 03.0" min. Double ended = (101.6 mm) 04.0" min. (2-4 positions) Double ended = (127.0 mm) 05.0" min. (5-10 positions)	-1 = Pin 01 to Pin 01
UMPT = Ultra Micro Tin Plating			-18 = 18 AWG	-M = Metal side latches	Teflon™ Fluoropolymer Double ended = (228.6 mm) 09.0" min. (2-4 positions) Double ended = (254.0 mm) 10.0" min. (5-10 positions)	-2 = Pin 01 to Pin N
			-18C = Color Coded Cable (UMPC only)			

UMPC(T)

Board Mates:

UMPT

(Plastic (-P) or metal (-M) latch required)

SPECIFICATIONS

Insulator Material:

Black LCP

Contact Material:

Copper Alloy

Plating:

Sn or Au over 50 μ" (1.27 μm) Ni

Wire:

16 or 18 AWG

Voltage Rating:

435 VAC/615 VDC

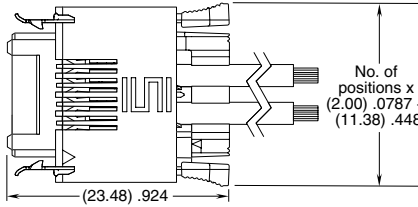

UMPC-04-X-XX-M-XX.X SHOWN

UMPC/UMPT (TIN PLATING)	
PINS	CURRENT RATING (PER CONTACT)
1	18.1 A
2	15.8 A
3	13.5 A
4	12.2 A
10	9.2 A

CABLE COLOR CODING	
PIN	COLOR
1	BROWN
2	RED
3	ORANGE
4	YELLOW
5	GREEN
6	BLUE
7	VIOLET
8	GRAY
9	WHITE
10	BLACK

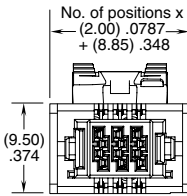

UMPC-03-X-XX-P-XX.X SHOWN

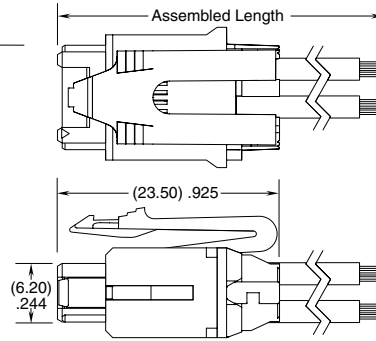

*Teflon™ is a trademark of The Chemours Company FC, LLC used under license by Samtec.

Note: For wiring option information refer to drawings on web.

View complete specifications at: samtec.com?UMPC & samtec.com?UMPT

UMPC CABLE HOLDER (Required for use with IMPC)

SERIES	NUMBER OF POSITIONS	LEAD STYLE
IMPC	-02, -03, -04, -05, -06, -07, -08, -09, -10	01 = 16 AWG
		02 = 18 AWG

IMPC	NO. OF POSITIONS	LATCH OPTION	CC489	01	PLATING	PACKAGING
	-02, -03, -04, -05, -06, -07, -08, -09, -10	-P = Plastic top latch			-L = 10 μ" (0.25 μm) Gold on contact, Tin on tail	-R = Full Reel (5,000 Contacts)
		-M = Metal side latches			-T = Tin	-M = Mini Reel (1,000 Contacts)
						-B = Bubble Bag (35 Contacts)

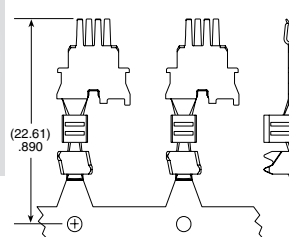
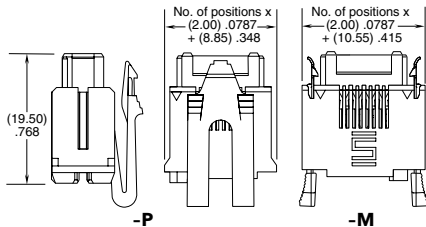

TOOLING

Hand Tool: CAT-HT-489-1618-13

Mini Applicator: CAT-MC-489-1618-XX-01

Note:

Some lengths, styles and options are non-standard, non-returnable.

View complete specifications at: samtec.com?IMPC & samtec.com?CC489

ULTRA MICRO CABLE-TO-CABLE

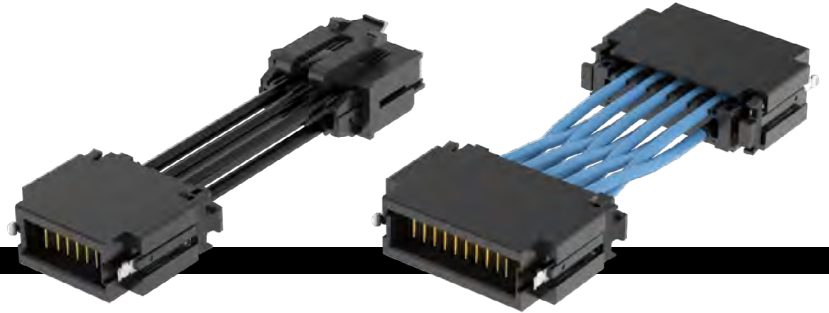

SERIES	NO. OF POSITIONS	PLATING OPTION	WIRE GAUGE	LENGTH	END 2 OPTION	PINOUT
UMPE = Ultra Micro PVC Cable UMPET = Ultra Micro Blue *Teflon™ Fluoropolymer Cable	-02, -03, -04, -05, -06, -07, -08, -09, -10	-L = 10 μ" (0.25 μm) Gold on contact, Tin on tail -T = Tin	-16 = 16 AWG -16C = 16 AWG Color Coded Cable (not available with UMPET) -18 = 18 AWG -18C = 18 AWG Color Coded Cable (not available with UMPET)	-"XX.X" = Assembled Length in Inches Single ended = (76.2 mm) 03.0" min. Double ended = (101.6 mm) 04.0" min. (2-4 positions) Double ended = (127.0 mm) 05.0" min. (5-10 positions)	(Leave blank for Single ended) -T = Terminal -S = Socket	(Leave blank for Single ended) -M1 = Metal Latch Pin 01 to Pin 01 -M2 = Metal Latch Pin 01 to Pin N -P1 = Plastic Latch Pin 01 to Pin 01 -P2 = Plastic Latch Pin 01 to Pin N (PX only available with -S end option)

UMPE(T)
Cable Mates:
UMPI(T)
End 2 Mates:
UMPI(T), UMPT

UMPET
PRELIMINARY

SPECIFICATIONS

Insulator Material: Black LCP
Contact Material: Copper Alloy
Plating: Sn or Au over 50 μ" (1.27 μm) Ni
Wire: 16 or 18 AWG
Current Rating: 16 AWG Tin = 18.5 A per pin
 18 AWG Tin = 17.5 A per pin
 16 AWG Gold = 22.5 A per pin
Voltage Rating: 445 VAC/629 VDC

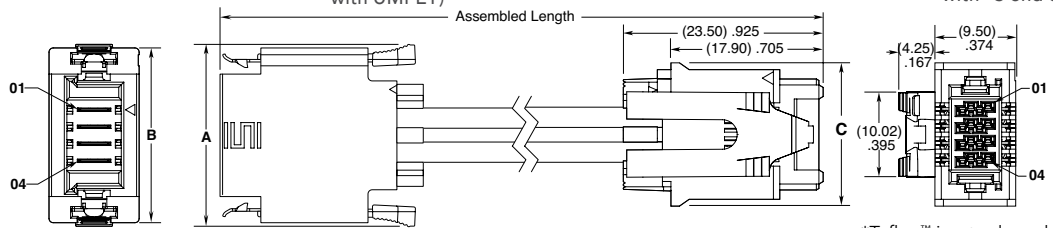

NO. OF POSITIONS	A	B	C
-02	(17.38) .684	(16.55) .652	(12.85) .506
-03	(19.38) .763	(18.55) .730	(14.85) .585
-04	(21.38) .842	(20.55) .809	(16.85) .663
-05	(23.38) .920	(22.55) .888	(18.85) .742
-06	(25.38) .999	(24.55) .967	(20.85) .821
-07	(27.38) 1.078	(26.55) 1.045	(22.85) .900
-08	(29.38) 1.157	(28.55) 1.124	(24.85) .978
-09	(31.38) 1.235	(30.55) 1.203	(26.85) 1.057
-10	(33.38) 1.314	(32.55) 1.281	(28.85) 1.136

CABLE COLOR CODING	
PIN	COLOR
1	BROWN
2	RED
3	ORANGE
4	YELLOW
5	GREEN
6	BLUE
7	VIOLET
8	GRAY
9	WHITE
10	BLACK

*Teflon™ is a trademark of The Chemours Company FC, LLC used under license by Samtec.

Notes: Teflon™ Fluoropolymer cable is intended for crimp only. Contact Samtec for solderable cable applications.



For wiring option information refer to drawings on web.

Some lengths, styles and options are non-standard, non-returnable

UMPE CABLE HOLDER (Required for use with UMPE)

SERIES	NUMBER OF POSITIONS	LEAD STYLE
IMPEC	-02, -03, -04, -05, -06, -07, -08, -09, -10	01 = 16 AWG 02 = 18 AWG

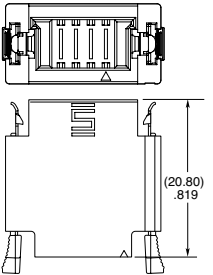
View complete specifications at: samtec.com?UMPE & samtec.com?UMPET

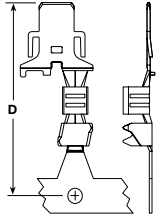
IMPE	NO. OF POSITIONS	LATCH OPTION	TC146	01	PLATING	HOT SWAP	PACKAGING						
	-02, -03, -04, -05, -06, -07, -08, -09, -10	-M = Metal Side Latches			-L = 10 μ" (0.25 μm) Gold on contact, Tin on tail -T = Tin	-1 = 6.60 -2 = 7.10	-R = Full Reel (5,000 Contacts) -M = Mini Reel (1,000 Contacts) -B = Bubble Bag (35 Contacts)						
							<table border="1"> <thead> <tr> <th>HOT SWAP</th> <th>D</th> </tr> </thead> <tbody> <tr><td>-1</td><td>(21.31) .839</td></tr> <tr><td>-2</td><td>(21.81) .859</td></tr> </tbody> </table>	HOT SWAP	D	-1	(21.31) .839	-2	(21.81) .859
HOT SWAP	D												
-1	(21.31) .839												
-2	(21.81) .859												

TOOLING

Hand Tool: CAT-HT-1146-1618-13

Mini Applicator: CAT-MC-489-1618-XX-01

View complete specifications at: samtec.com?IMPE & samtec.com?TC146

ULTRA MICRO CABLE-TO-CABLE

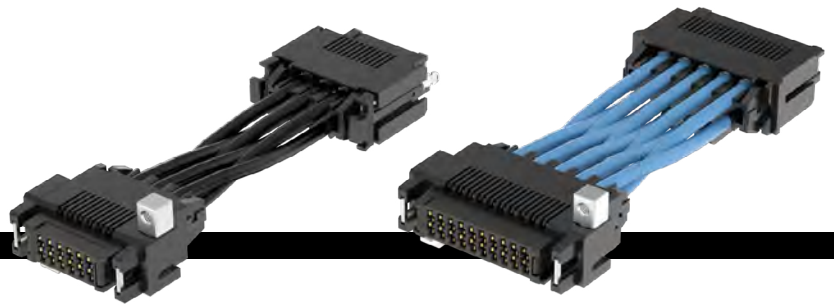

SERIES	NO. OF POSITIONS	PLATING OPTION	WIRE GAUGE	LENGTH	PINOUT
UMPI = Ultra Micro PVC Cable UMPIT = Ultra Micro Blue *Teflon™ Fluoropolymer Cable	-02, -03, -04, -05, -06, -07, -08, -09, -10	-L = 10 μ" (0.25 μm) Gold on contact, Tin on tail -T = Tin	-16 = 16 AWG -16C = 16 AWG Color Coded Cable (not available with UMPIT) -18 = 18 AWG -18C = 18 AWG Color Coded Cable (not available with UMPIT)	-"XX.X" = Assembled Length in Inches Single ended = (76.2 mm) 03.0" min. Double ended = (101.6 mm) 04.0" min. (2-4 positions) Double ended = (127.0 mm) 05.0" min. (5-10 positions)	(Leave blank for Single ended) -M1 = Metal Latch Pin 01 to Pin 01 -M2 = Metal Latch Pin 01 to Pin N -P1 = Plastic Latch Pin 01 to Pin 01 -P2 = Plastic Latch Pin 01 to Pin N

UMPT PRELIMINARY

UMPI(T)
Cable Mates:
UMPE(T)
End 2 Mates:
UMPE(T), UMPT

SPECIFICATIONS

Insulator Material:
Black LCP
Contact Material:
Copper Alloy
Plating:
Sn or Au over 50 μ" (1.27 μm) Ni
Wire:
16 or 18 AWG
Current Rating:
16 AWG Tin = 18.5 A per pin
18 AWG Tin = 17.5 A per pin
16 AWG Gold = 22.5 A per pin
Voltage Rating:
445 VAC/629 VDC

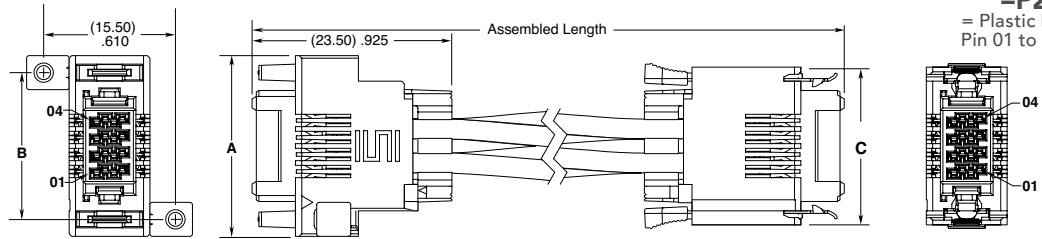

CABLE COLOR CODING	
PIN	COLOR
1	BROWN
2	RED
3	ORANGE
4	YELLOW
5	GREEN
6	BLUE
7	VIOLET
8	GRAY
9	WHITE
10	BLACK

NO. OF POSITIONS	A	B	C
-02	(17.25) .679	(13.25) .522	(14.55) .573
-03	(19.25) .758	(15.25) .600	(16.55) .652
-04	(21.25) .837	(17.25) .679	(18.55) .730
-05	(23.25) .915	(19.25) .758	(20.55) .809
-06	(25.25) .994	(21.25) .837	(22.55) .888
-07	(27.25) 1.073	(23.25) .915	(24.55) .967
-08	(29.25) 1.152	(25.25) .994	(26.55) 1.045
-09	(31.25) 1.230	(27.25) 1.073	(28.55) 1.124
-10	(33.25) 1.309	(29.25) 1.152	(30.55) 1.203

*Teflon™ is a trademark of The Chemours Company FC, LLC used under license by Samtec.

Notes:
Teflon™ Fluoropolymer cable is intended for crimp only. Contact Samtec for solderable cable applications.

For wiring option information refer to drawings on web.

Some lengths, styles and options are non-standard, non-returnable

View complete specifications at: samtec.com?UMPI & samtec.com?UMPIT

UMPI CABLE HOLDER (Required for use with IMPC)

SERIES	NUMBER OF POSITIONS	LEAD STYLE
IMPC	-02, -03, -04, -05, -06, -07, -08, -09, -10	01 = 16 AWG
		02 = 18 AWG

IMPC	NO. OF POSITIONS	LATCH OPTION	CC489	01	PLATING	PACKAGING
------	------------------	--------------	-------	----	---------	-----------

-02, -03, -04, -05, -06, -07, -08, -09, -10
-P1 = Panel Mount

-L = 10 μ" (0.25 μm) Gold on contact, Tin on tail
-R = Full Reel (5,000 Contacts)
-M = Mini Reel (1,000 Contacts)
-B = Bubble Bag (35 Contacts)

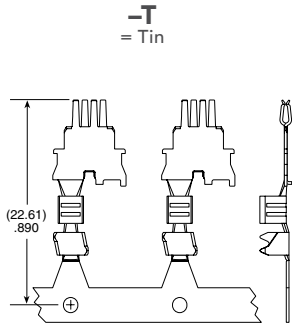
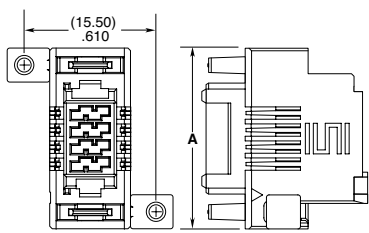
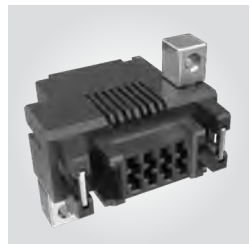

TOOLING

Hand Tool: CAT-HT-489-1618-13

Mini Applicator: CAT-MC-489-1618-XX-01

View complete specifications at: samtec.com?IMPC & samtec.com?CC489

Note:
Some lengths, styles and options are non-standard, non-returnable.

LOW PROFILE, EXTREME HIGH-POWER/SIGNAL COMBO

FEATURES & BENEFITS

- 30 A per power blade and 2.5 A per signal pin
- Low 7.5 mm profile design (right-angle) for improved system airflow and space savings
- Double-stacked power blades per bank for increased density and power
- Ideal for coplanar and perpendicular applications
- Rugged guide posts are standard for blind mating assistance
- Socket available as vertical with press-fit tails and right-angle through-hole; mates with terminal or standard .062" (1.60 mm) PCB card

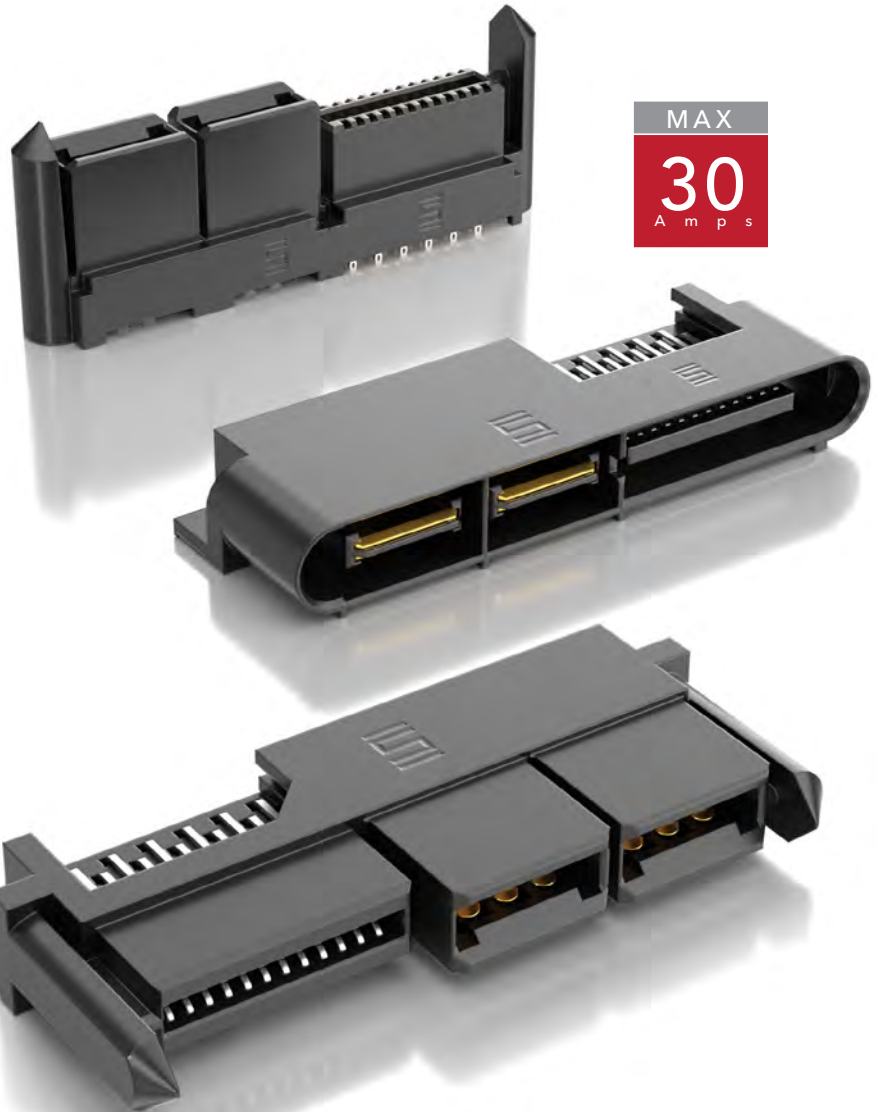

MAX
30
A m p s

Standard Creepage*	5.63 mm
Standard Clearance*	2.69 mm

*Selectively loading contacts achieves customer specific creepage and clearance requirements. Contact asp@samtec.com

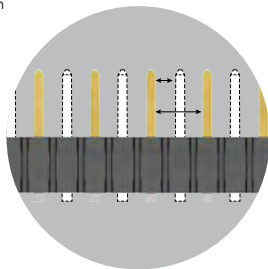

KEY SPECIFICATIONS (LPHT/LPHS)

PITCH	INSULATOR MATERIAL	TERMINAL MATERIAL	PLATING	OPERATING TEMP RANGE	CURRENT RATING	VOLTAGE RATING	MATING CYCLES	LEAD-FREE SOLDERABLE
(12.00 mm) .472" (pwr) (1.27 mm) .050" (sig)	Black LCP	Signal: Brass Power: Copper Alloy	Au or Sn over 50 μ" (1.27 μm) Ni	-40 °C to +105 °C	30 A (Power Blade) 2.5 A (Signal Pin)	250 VAC / 354 VDC	250 (MFG Tested)	Yes (RT1 & RT2 option)

Notes:

Series is rated up to 60 A per power bank.
Some lengths, styles and options are non-standard, non-returnable.
The Molex EXTreme LPHPower™ line is a second source to the Samtec LPHT/LPHS Series.
*EXTreme LPHPower™ is a trademark of Molex Incorporated.

30 A SIGNAL/POWER COMBO SYSTEM

SERIES	POWER POSITIONS	SIGNAL POSITIONS	PLATING OPTION	TAIL	GP
LPHT Terminal LPHS Socket	Total, 2 per power bank -02, -04, -06, -08, -10	Total -12, -16, -20, -24, -32	-L = 10 μ" (0.25 μm) Gold on contact, Matte Tin on tail	-VP1 = Vertical Press-fit (LPHS only) -RT1 = Right-angle Through-hole (Use with (1.60 mm) .062" thick board) -RT2 = Right-angle Through-hole (Use with (2.36 mm) .093" thick board)	

LPHT
Board Mates:
LPHS



SIGNAL POSITIONS	POWER POSITIONS				
	A (-02)	A (-04)	A (-06)	A (-08)	A (-10)
-16	(33.97) 1.337	(45.97) 1.810	(57.97) 2.282	(69.97) 2.755	(81.97) 3.227
-20	(36.51) 1.437	(48.51) 1.910	(60.51) 2.382	(72.51) 2.855	(84.51) 3.327
-24	(39.05) 1.537	(51.05) 2.010	(63.05) 2.482	(75.05) 2.955	(87.05) 3.427
-32	(44.13) 1.737	(56.13) 2.210	(68.13) 2.682	(80.13) 3.155	(92.13) 3.627

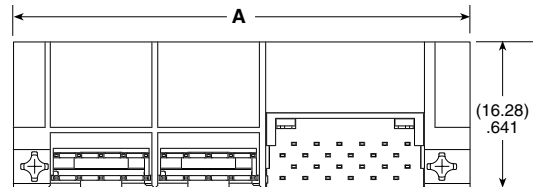
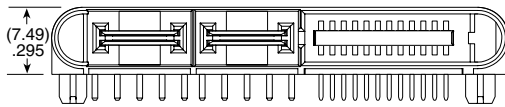

View complete specifications at: samtec.com?LPHT

LPHS
Board Mates:
LPHT

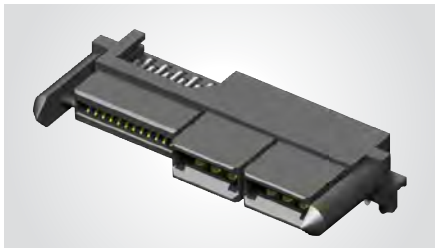

SIGNAL POSITIONS	POWER POSITIONS									
	A (-02)	B (-02)	A (-04)	B (-04)	A (-06)	B (-06)	A (-08)	B (-08)	A (-10)	B (-10)
-16	(31.64) 1.246	(25.88) 1.019	(43.64) 1.718	(37.88) 1.491	(55.64) 2.191	(49.88) 1.964	(67.64) 2.663	(61.88) 2.436	(79.64) 3.135	(73.88) 2.909
-20	(34.18) 1.346	(28.42) 1.119	(46.18) 1.818	(40.42) 1.591	(58.18) 2.291	(52.42) 2.064	(70.18) 2.763	(64.42) 2.536	(82.18) 3.235	(76.42) 3.009
-24	(36.72) 1.446	(30.96) 1.219	(48.72) 1.918	(42.96) 1.691	(60.72) 2.391	(54.96) 2.164	(72.72) 2.863	(66.96) 2.636	(84.72) 3.335	(78.96) 3.109
-32	(41.80) 1.646	(36.04) 1.419	(53.80) 2.118	(48.04) 1.891	(65.80) 2.591	(60.04) 2.364	(77.80) 3.063	(72.04) 2.836	(89.80) 3.535	(84.04) 3.309

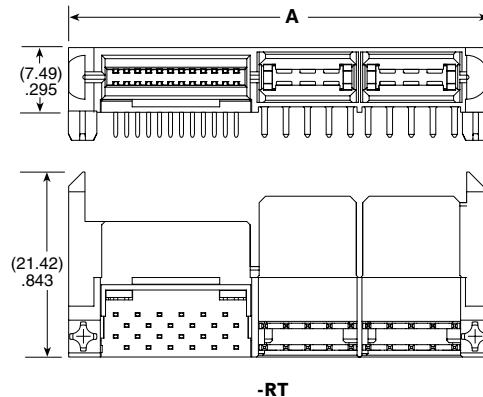
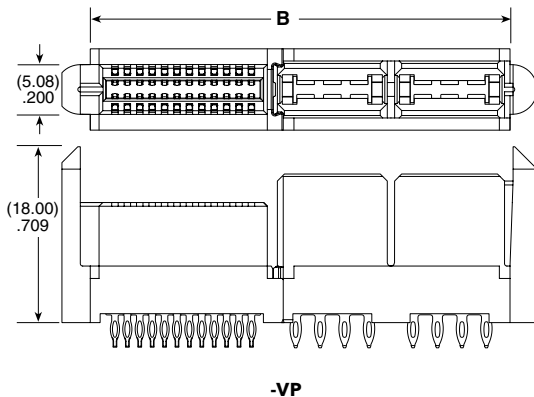

-VP

-RT

View complete specifications at: samtec.com?LPHS

POWER™ EXTreme STRIP Ten60

EXTREME HIGH-POWER 60 A SYSTEMS

FEATURES & BENEFITS

- Up to 60 A per power blade (2 blades powered)
- Split Power Option: 30 A/30 A for a total of 60 A
- Low 10 mm profile (right-angle) for enhanced system airflow
- Power only, or power/signal combinations
- 3 or 5 signal rows in the same form factor
- AC power, DC power, power/signal combinations and split power options available
- Coplanar and perpendicular solutions supporting mid-board or backplane applications
- Modules can be configured to accommodate most any design
- Rugged guide posts are standard; top design for board space savings
- Press-fit (ET60S only) and hot swap (ET60T only) options available



Standard Creepage*	3.02 mm
Standard Clearance*	1.87 mm

*Selectively loading contacts achieves customer specific creepage and clearance requirements. Contact asp@samtec.com

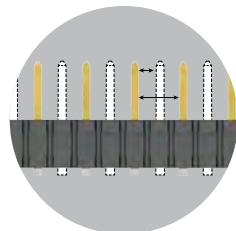

SPLIT POWER

8 mm (.315") pitch
Blade: 30 A / 30 A

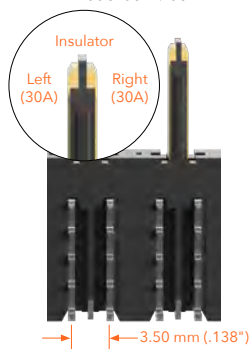

DC POWER

5.50 mm (.217") pitch
Blade: 60 A



AC POWER

7.50 mm (.295") pitch
Blade: 60 A



BOTTOM VIEW

KEY SPECIFICATIONS (ET60T/ET60S)

	PITCH	INSULATOR MATERIAL	TERMINAL MATERIAL	PLATING	OPERATING TEMP RANGE	CURRENT RATING	VOLTAGE RATING	MATING CYCLES	LEAD-FREE SOLDERABLE
Power	(5.50 mm) .217" (DC) (7.50 mm) .295" (AC) (8.00 mm) .315" (SP)	Black LCP	Signal: Phosphor Bronze Power: Copper Alloy	Au or Sn over 50 μ" (1.27 μm) Ni	-40 °C to +105 °C	60 A (Power Pin) 30 A/30 A (Split Power) 3.3 A (Signal Pin)	300 VAC/ 424 VDC	500	Yes
Signal	(2.00 mm) .097" (5 row) (2.54 mm) .100" (3 row)								

Notes:

Some lengths, styles and options are non-standard, non-returnable.
*EXTreme Ten60Power™ is a trademark of Molex Incorporated and is dual sourced by Molex®

60 A SIGNAL/POWER COMBO SYSTEM

SERIES	POWER OPTION (R)	ROWS	SIGNAL POS. PER ROW	POWER OPTION (L)	PLATING	TAIL	GUIDE POST	OPTION
ET60T Terminal	-AXX = AC Power Positions (02 - 06)	-0 = No Signal	-00 = No Signal	-AXX = AC Power Positions (02 - 06)	-L = 10 μm (0.25 μm) Gold on contact, Matte Tin on tail (Not available for 5 rows)	-R1 = Right-angle Through-hole (Use with (1.60 mm) .062" thick card)	(Required callout)	(Leave blank for no hot swap)
ET60S Socket	-DXX = DC Power Positions (02 - 10)	-3	-08 = 3 Row only	-DXX = DC Power Positions (02 - 10)		-VP = Vertical Press-fit (Not available with ET60T)	-S = Side Guide Post	-H = Hot Swap (ET60T only)
	-SXX = Split Power (01 - 03)	-5	-01, -02, -03, -04, -05, -06, -07, -08 = 5 Row only	-SXX = Split Power (01 - 03)		-V1 = Vertical Through-hole (Use with (1.60 mm) .062" thick card) (-0 and -3 Row only) (Not available with ET60T)	-T = Top Guide Post (Not available with -SXX)	
	-000 = No Power			-000 = No Power				

ET60T
Board Mates:
ET60S

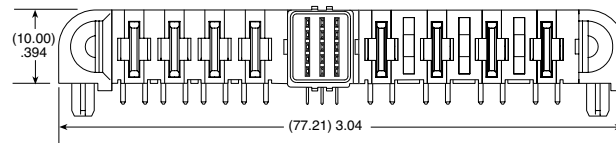
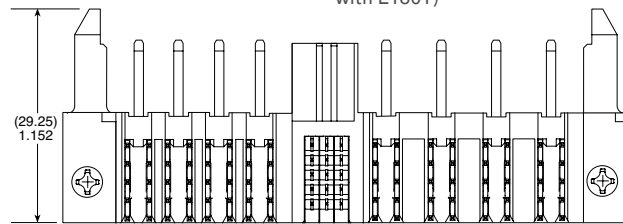
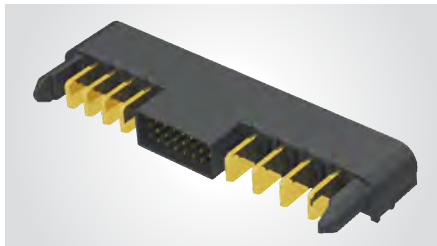

ET60T-D04-5-03-A04-X-R1-S SHOWN

View complete specifications at: samtec.com?ET60T

ET60S
Board Mates:
ET60T

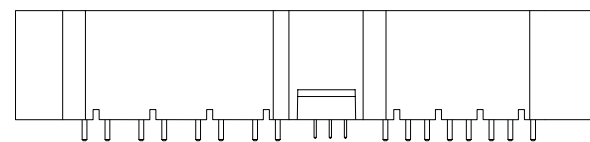
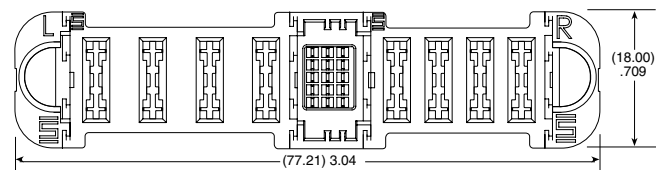

VERTICAL

ET60S-D04-5-03-A04-X-VP-S SHOWN

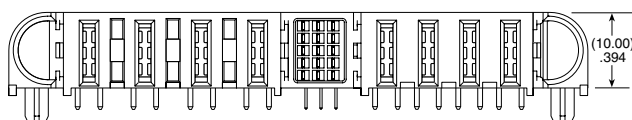

RIGHT-ANGLE

ET60S-D04-5-03-A04-X-R1-S SHOWN

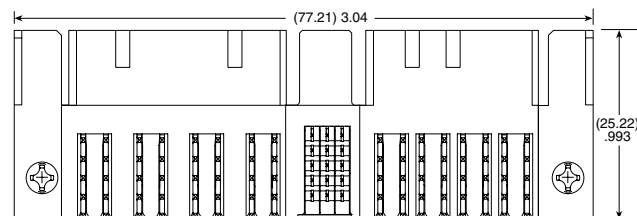

View complete specifications at: samtec.com?ET60S

HIGH POWER SYSTEMS

20-60 A
per blade

FEATURES & BENEFITS

- Current Rating: 23 A - 58.7 A per power blade
- 3.81 mm, 5.00 mm and 6.35 mm pitch
- Dual blade contact system
- Power only or power/signal combinations available
- Right-angle and vertical orientations
- Rugged screw down and locking clip options
- Wire to board assemblies with 10-16 AWG wire (see pages 262-264)
- "Hinged" for unique mating in any orientation from 0° to 90° and space confined applications

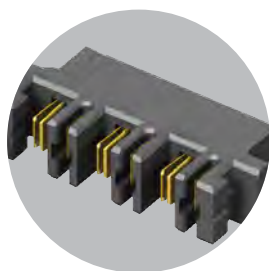

Hermaphroditic options
samtec.com?MPPT and
samtec.com?UPPT

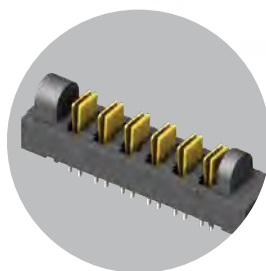

Hinging options available
samtec.com?FMPT and
samtec.com?FMPS

CREEPAGE & CLEARANCE

SERIES	CREEPAGE	CLEARANCE
UPT/UPS/UPPT	5.50 mm	1.51 mm
MPT/MPS/MPTC/MPSC	2.95 mm	2.71 mm
PET/PES/PETC/PESC	3.66 mm	3.31 mm

Selectively loading contacts achieves customer specific creepage and clearance requirements.

KEY SPECIFICATIONS

SERIES	PITCH	INSULATOR MATERIAL	CONTACT MATERIAL	PLATING	OPERATING TEMP RANGE	CURRENT RATING	VOLTAGE RATING	LEAD-FREE SOLDERABLE
UPT/UPS	(3.81 mm) .150"	Black LCP	BeCu	Sn or Au over 50 μ" (1.27 μm) Ni	-55 °C to +105 °C (Sn) -55 °C to +125 °C (Au)	23 A (1 pin powered)	438 VAC/619 VDC	Yes
UPPT	(3.81 mm) .150"	Black LCP	Copper Alloy	Sn or Au over 50 μ" (1.27 μm) Ni	-55 °C to +105 °C (Sn) -55 °C to +125 °C (Au)	21.4 A (1 pin powered)	425 VAC/601 VDC	Yes
MPT/MPS	(5.00 mm) .1969"	Black LCP	Copper Alloy	Sn or Au over 50 μ" (1.27 μm) Ni	-55 °C to +105 °C (Sn) -55 °C to +125 °C (Au)	28 A (1 pin powered)	575 VAC/813 VDC	Yes
MPTC/MPSC	(5.00 mm) .197" (pwr) (2.00 mm) .079" (sig)	Black LCP	Signal: Phosphor Bronze Terminal: Copper Alloy	Sn or Au over 50 μ" (1.27 μm) Ni	-55 °C to +105 °C (Sn) -55 °C to +125 °C (Au)	28 A (pwr - 1 pin powered) 5 A (sig - 4 pins powered)	250 VAC/353 VDC	Yes
PET/PES	(6.35 mm) .250"	Black LCP	Copper Alloy	Sn or Au over 50 μ" (1.27 μm) Ni	-55 °C to +105 °C (Sn) -55 °C to +125 °C (Au)	58.7 A (1 pin powered)	450 VAC/636 VDC	Yes
PETC/PESC	(6.35 mm) .250" (pwr) (2.54 mm) .100" (sig)	Black LCP	Copper Alloy	Sn or Au over 50 μ" (1.27 μm) Ni	-55 °C to +105 °C (Sn) -55 °C to +125 °C (Au)	31 A (pwr - 1 pin powered) 5.7 A (sig - 4 pins powered)	650 VAC/920 VDC (pwr) 450 VAC/636 VDC (sig)	Yes

(3.81 mm) .150" PITCH • 20 A DUAL BLADE/LEAF POWER SYSTEMS

SERIES	POWER PINS	LEAD STYLE	TAIL LENGTH	PLATING OPTION	TAIL	OTHER OPTION	"X"R
UPT Terminal	-02	-01 = RA only	-01 = Use with (1.60 mm) .062" Thick PCB (-V & -RA only)	-L = 10 μ" (0.25 μm) Gold on contact, Matte Tin on tail	-V = Vertical (Not available with -T plating)	-LC = Locking Clip (Manual placement required) Not available with -PV option	Leave blank for tube packaging
	-04	-03.0 = (03.0 mm) .118" (UPT-V & UPT-PV only)	-03 = Use with (1.60 mm) .062" Thick PCB (-PV only)	-T = Matte Tin (-RA & -PV options only)	-RA = Right-angle		-TR = Tape & Reel
UPS Socket	-06	-04.0 = (04.0 mm) .157" (UPS-V & UPS-PV only)			-PV = Press-fit, Vertical		-FR = Full Reel Tape & Reel (must order max. quantity per reel; contact Samtec for quantity breaks)
	-08	-07.0 = (07.0 mm) .276" (UPS-V & UPS-PV only)					

UPT
Board Mates:
UPS

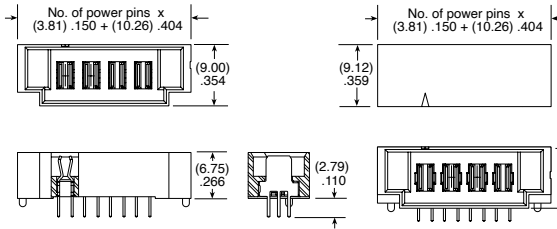

MATED HEIGHT*	
UPS LEAD STYLE	UPT LEAD STYLE
-03.0	-03.0
-04.0	(7.00) .276
-07.0	(10.00) .394

UPS
Board Mates:
UPT

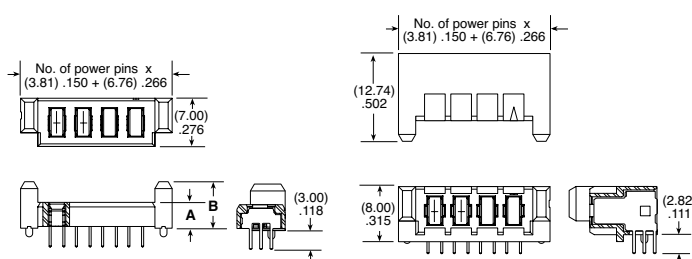
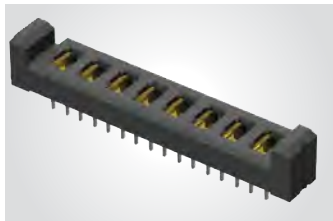

LEAD STYLE	A	B
-04.0	(3.75) .148	(6.75) .266
-07.0	(6.75) .266	(9.75) .384

*Processing conditions will affect mated height.

View complete specifications at: samtec.com?UPT & samtec.com?UPS

SERIES	NO. OF POSITIONS	01	TAIL LENGTH	PLATING OPTION	RA	SD	"X"R
UPPT Hermaphroditic	-02, -04, -06, -08		-01 = (1.60 mm) .062" Thick PCB	-L = 10 μ" (0.25 μm) Gold on contact, Matte Tin on tail			Leave blank for tube packaging
UPPT Board Mates: UPPT				-T = Matte Tin			-TR = Tape & Reel
							-FR = Full Reel Tape & Reel (must order max. quantity per reel; contact Samtec for quantity breaks)

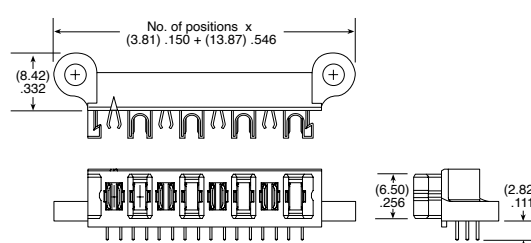
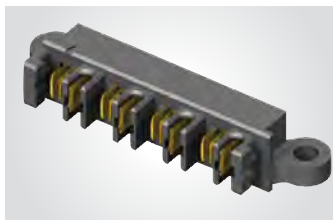

Note:
Some lengths, styles and options are non-standard, non-returnable

View complete specifications at: samtec.com?UPPT

(5.00 mm) .1969" PITCH • 30 A DUAL BLADE/LEAF SYSTEMS

SERIES	POWER PINS	LEAD STYLE	TAIL LENGTH	PLATING OPTION	TAIL
MPT Terminal	-02, -03, -04, -06, -08	-6.30 = (6.30 mm) 0.248" (MPT only)	-01 = Use with (1.60 mm) .062" Thick PCB -03 = Use with (2.36 mm) .093" Thick PCB	-L = 10 μ" (0.25 μm) Gold on contact, Matte Tin on tail -T = Matte Tin	(Required Callout) -V = Vertical
MPS Socket		-7.70 = (7.70 mm) 0.303" (MPS only)			

MPT

Board Mates:

MPS

Cable Mates:

MPSS

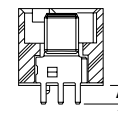
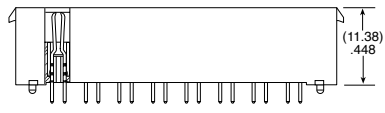
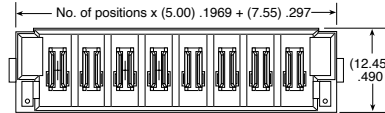

TAIL LENGTH	A
-01	(2.72) .107
-03	(3.51) .138

MATED HEIGHT

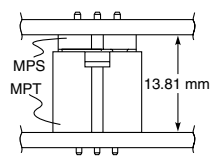

MPS

Board Mates:

MPT

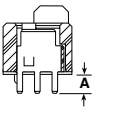
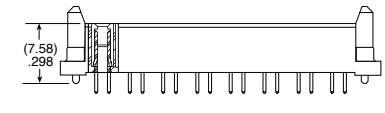
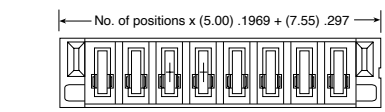
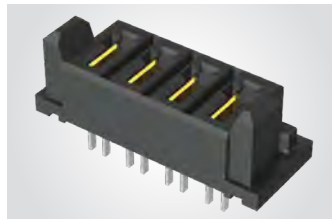

TAIL LENGTH	A
-01	(2.72) .107
-03	(3.52) .139

View complete specifications at: samtec.com?MPT & samtec.com?MPS

SERIES	POWER PINS	01	TAIL LENGTH	PLATING OPTION	RA	SD
MPT Terminal	-02, -04, -06, -08		-01 = Use with (1.60 mm) .062" Thick PCB -03 = Use with (2.36 mm) .093" Thick PCB	-L = 10 μ" (0.25 μm) Gold on contact, Matte Tin on tail -T = Matte Tin		
MPS Socket						

MPT-RA

Board Mates:

MPS

Cable Mates:

MPSS

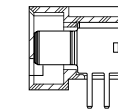
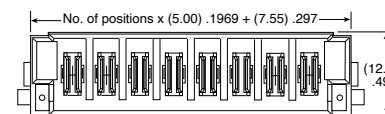
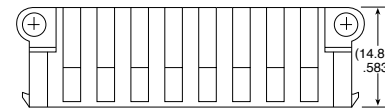

TAIL LENGTH	A
-01	(2.72) .107
-03	(3.51) .138

MPS-RA

Board Mates:

MPT

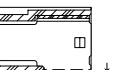
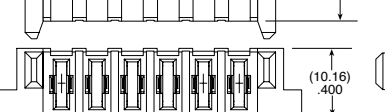
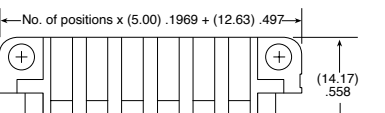

TAIL LENGTH	A
-01	(2.72) .107
-03	(3.52) .139

Note:
Some lengths, styles and options are non-standard, non-returnable

View complete specifications at: samtec.com?MPT & samtec.com?MPS

(5.00 mm) .197"(PWR) / (2.00 mm) .079"(SIG) • 30 A SIGNAL/POWER COMBO SYSTEMS

SERIES	POWER PINS	SIGNAL PINS	POWER PINS	LEAD STYLE	TAIL LENGTH	PLATING OPTION	V	OTHER OPTION
MPTC Terminal	Per end -01	-16 -24	Per end -01	-6.30 = (6.30 mm) 0.248" (MPTC only)	-01 = Use with (1.60 mm) .062" Thick PCB	-L = 10 μ" (0.25 μm) Gold on contact, Matte Tin on tail (Power & Signal)		-LC = Locking Clip (Manual placement required)
MPSC Socket	-02	-40 -80	-02	-7.70 = (7.70 mm) 0.303" (MPSC only)	-03 = Use with (2.36 mm) .093" Thick PCB	-T = Matte tin on contact and tail (power), Gold on contact, Matte tin on tail (Signal)		

MPTC

Board Mates:
MPSC
Cable Mates:
MPCC

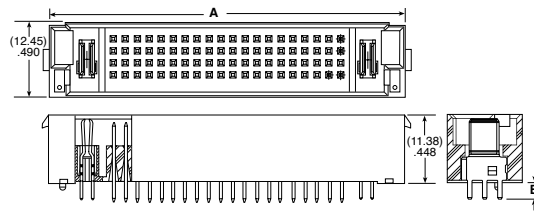

TAIL LENGTH	B
-01	(2.72) .107
-03	(3.51) .138

POWER PINS/ENDS	A			
	16 SIGNAL PINS	24 SIGNAL PINS	40 SIGNAL PINS	80 SIGNAL PINS
-01	(27.44) 1.081	(31.45) 1.238	(39.44) 1.553	(59.44) 2.340
-02	(37.44) 1.474	(41.45) 1.632	(49.44) 1.946	(69.44) 2.734

MPSC

Board Mates:
MPTC

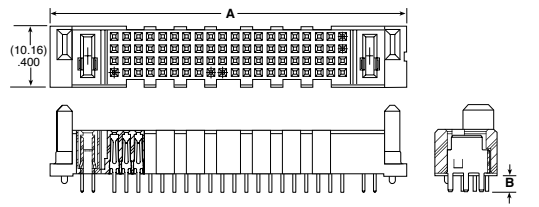
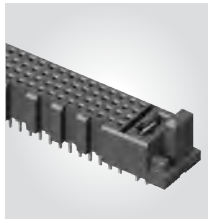

TAIL LENGTH	B
-01	(2.72) .107
-03	(3.52) .139

View complete specifications at: samtec.com?MPTC & samtec.com?MPSC

SERIES	POWER PINS	SIGNAL PINS	POWER PINS	01	TAIL LENGTH	PLATING OPTION	RA	OTHER OPTION
MPTC Terminal	Per end -01	-24 -80	Per end -01		-01 = Use with (1.60 mm) .062" Thick PCB	-L = 10 μ" (0.25 μm) Gold on contact, Matte Tin on tail (Power & Signal)		-SD or -LC is a required callout
MPSC Socket	-02		-02		-03 = Use with (2.36 mm) .093" Thick PCB	-T = Matte Tin on contact and tail (power), Gold on contact, Matte tin on tail (Signal)		-SD = Screw Down
								-LC = Locking Clip (Manual placement required)

MPTC-RA

Board Mates:
MPSC
Cable Mates:
MPCC

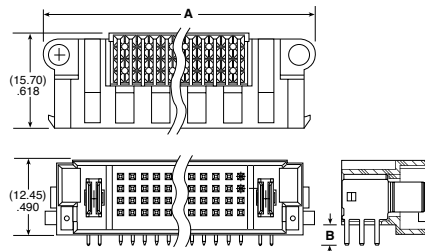
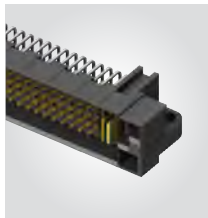

TAIL LENGTH	B
-01	(2.72) .107
-03	(3.51) .138

POWER PINS/ENDS	A	
	24 SIGNAL PINS	80 SIGNAL PINS
-01	(35.25) 1.388	(63.25) 2.490
-02	(45.25) 1.781	(73.25) 2.884

MPSC-RA

Board Mates:
MPTC

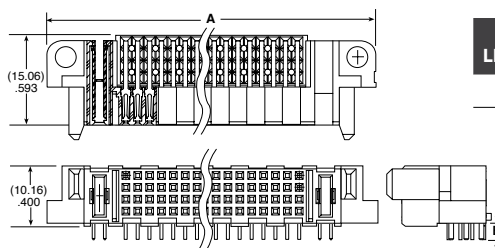

TAIL LENGTH	B
-01	(2.20) .087
-03	(3.00) .118

POWER PINS/ENDS	A	
	24 SIGNAL PINS	80 SIGNAL PINS
-01	(36.52) 1.438	(64.52) 2.540
-02	(46.52) 1.831	(74.52) 2.934

Note: Some lengths, styles and options are non-standard, non-returnable

View complete specifications at: samtec.com?MPTC & samtec.com?MPSC

(6.35 mm) .250" PITCH • 40 A HIGH-POWER SYSTEM

PET	NO. PINS PER ROW	LEAD STYLE	PLATING OPTION	TAIL OPTION	OTHER OPTION
	-02, -04, -06, -08	-01 = Use with (1.60 mm) .062" Thick PCB -02 = Use with (3.18 mm) .125" Thick PCB	-L = 10 μ" (0.25 μm) Gold on contact, Matte Tin on tail -T = Matte Tin	-VT = Vertical -RA = Right-angle (Screw Down option required)	-SD = Screw Down (Right-angle only)

PET

Board Mates:
PES
Cable Mates:
PESS

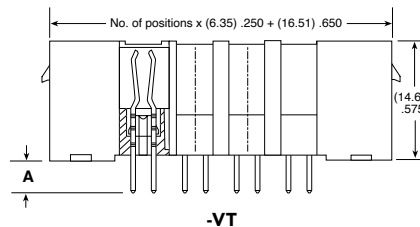

TAIL LENGTH	A
-01	(2.35) .093
-02	(3.95) .156

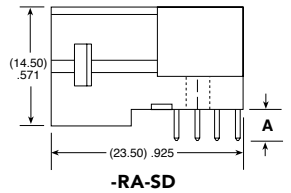

Note: Some lengths, styles and options are non-standard, non-returnable

View complete specifications at: samtec.com?PET

PES	NO. PINS PER ROW	LEAD STYLE	PLATING OPTION	TAIL OPTION	OTHER OPTION
	-02, -04, -06, -08	-01 = Use with (1.60 mm) .062" Thick PCB -02 = Use with (3.18 mm) .125" Thick PCB	-L = 10 μ" (0.25 μm) Gold on contact, Matte Tin on tail -T = Matte Tin	-VT = Vertical -RA = Right-angle (Screw Down option required)	-SD = Screw Down (Right-angle only)

PES

Board Mates:
PET

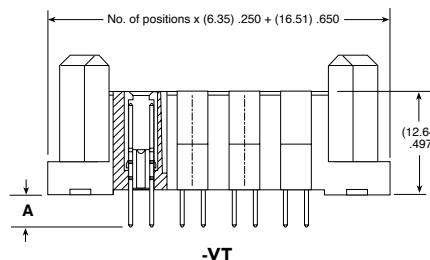

TAIL LENGTH	A	B
-01	(2.47) .097	(2.35) .093
-02	(4.07) .160	(3.95) .156

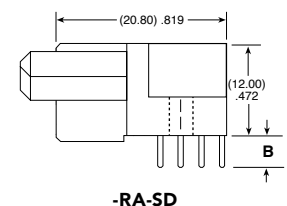

Note: Some lengths, styles and options are non-standard, non-returnable

View complete specifications at: samtec.com?PES

(6.35 mm) .250" PITCH • 40 A HIGH POWER/SIGNAL SYSTEM

PETC	POWER PINS	SIGNAL PINS	POWER PINS	01	PLATING OPTION	TAIL	OTHER OPTION
	-01, -02, -04	-12, -40	-01, -02, -04		-L = 10 μ" (0.25 μm) Gold on contact, Matte Tin on tail -T = Matte Tin	-VT = Vertical -RA = Right-angle	-SD = Screw Down (Right-angle only) -LC = Locking Clip (Manual placement required)

PETC
Board Mates:
PESC

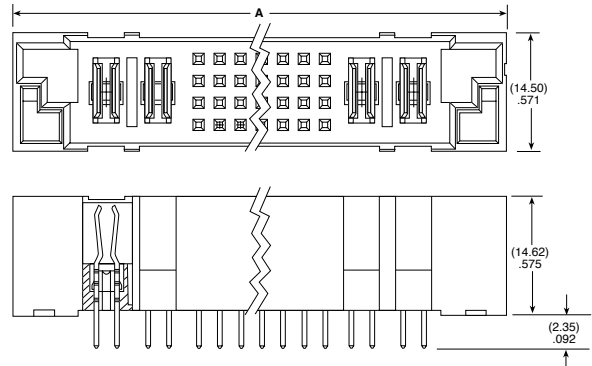

POWER PINS/ENDS	A	
	12 SIGNAL PINS	40 SIGNAL PINS
-01	(39.37) 1.550	(57.15) 2.250
-02	(52.07) 2.050	(69.85) 2.750
-04	(77.47) 3.050	(95.25) 3.750

Note:
Some lengths, styles and options are non-standard, non-returnable

View complete specifications at: samtec.com?PETC

PESC	POWER PINS	SIGNAL PINS	POWER PINS	01	PLATING OPTION	TAIL	OTHER OPTION
	-01, -02, -04	-12, -40	-01, -02, -04		-L = 10 μ" (0.25 μm) Gold on contact, Matte Tin on tail -T = Matte Tin	-VT = Vertical -RA = Right-angle	-SD = Screw Down (Right-angle only) -LC = Locking Clip (Manual placement required)

PESC
Board Mates:
PETC

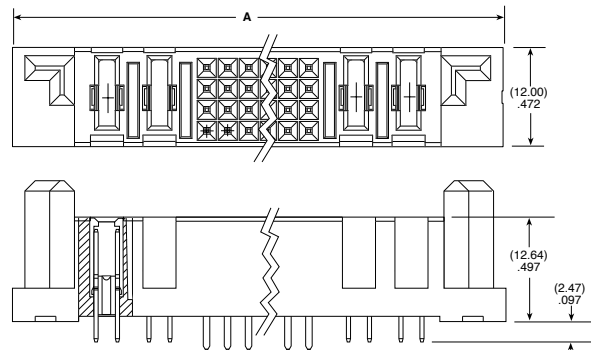
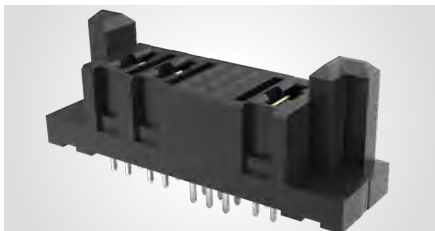

POWER PINS/ENDS	A	
	12 SIGNAL PINS	40 SIGNAL PINS
-01	(39.37) 1.550	(57.15) 2.250
-02	(52.07) 2.050	(69.85) 2.750
-04	(77.47) 3.050	(95.25) 3.750

Note:
Some lengths, styles and options are non-standard, non-returnable

View complete specifications at: samtec.com?PESC

ISOLATED POWER SYSTEMS

FEATURES & BENEFITS

- Individually shrouded contacts for electrical and mechanical protection
- .100" (2.54 mm) and .165" (4.19 mm) pitch
- Surface mount or through-hole
- Vertical and right-angle for parallel, perpendicular and coplanar applications
- Locking clip, key polarization and guide post options
- Wire to board assemblies with 16-30 AWG PVC or Teflon™ fluoropolymer wire.
- Metal or plastic rugged latching system

*Teflon™ is a trademark of The Chemours Company FC, LLC used under license by Samtec

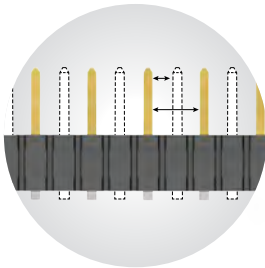

Selectively loading contacts achieves customer specific creepage and clearance requirements.

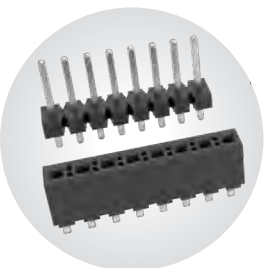

Flexible standard or high-power stacking systems with Power Eye three-finger BeCu contacts for reliable connection. For available series, visit samtec.com/flexiblestrips

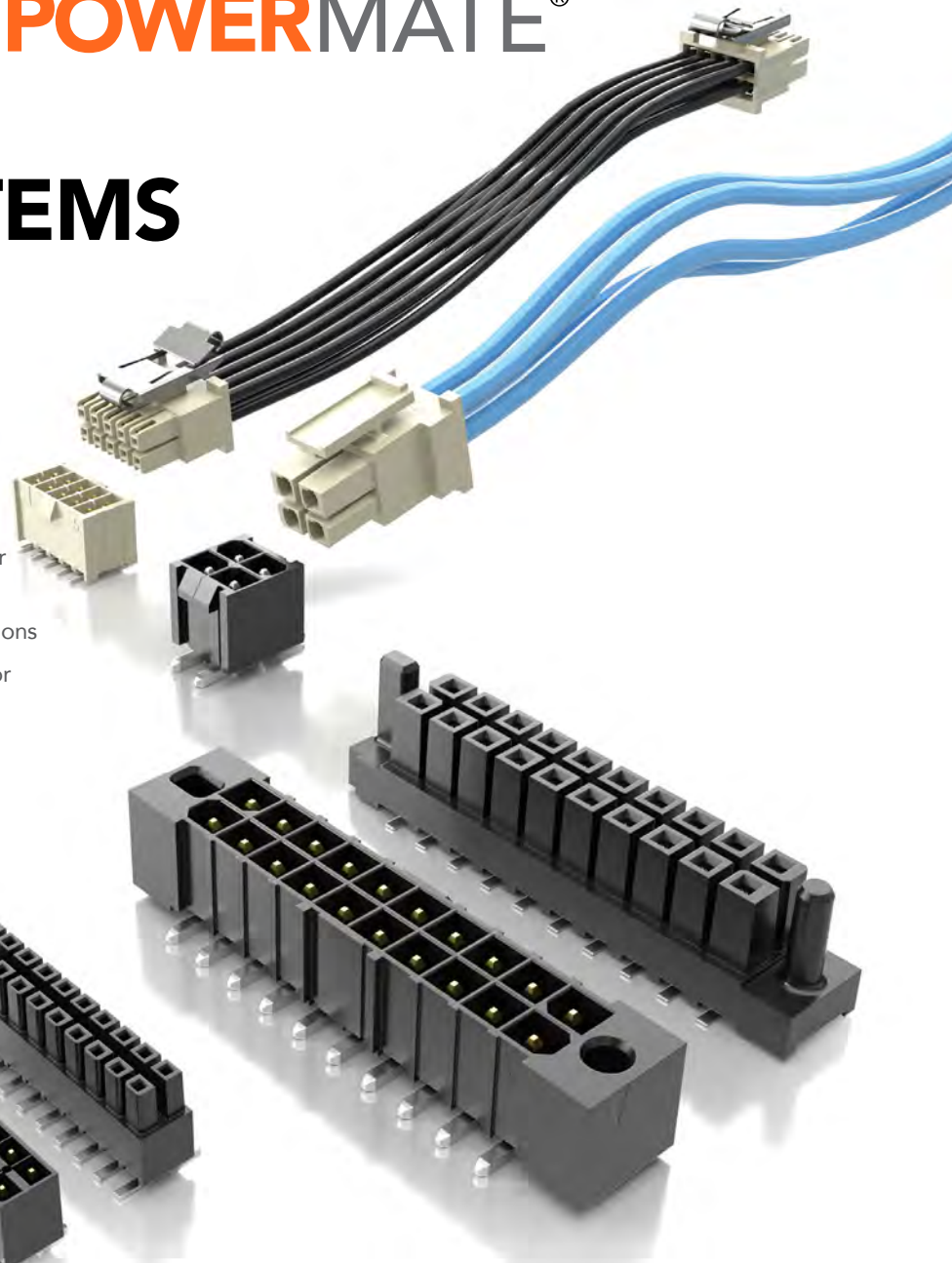

CREEPAGE & CLEARANCE

	CREEPAGE	CLEARANCE
IPT1/IPS1 MMSS(T)/MMSD(T)/IPL1	2.54 mm	1.91 mm
IPBT/IPBS PMSS(T)/PMSD(T)	4.27 mm	3.05 mm

Selectively loading contacts achieves customer specific creepage and clearance requirements.

KEY SPECIFICATIONS

SERIES	PITCH	INSULATOR MATERIAL	CONTACT MATERIAL	PLATING	OPERATING TEMP RANGE	CURRENT RATING	VOLTAGE RATING	LEAD-FREE SOLDERABLE
IPT1/IPS1	.100" (2.54 mm)	Black LCP	Phosphor Bronze	Sn or Au over 50 μ" (1.27 μm) Nickel	-55 °C to +125 °C	5.9 A (2 pins power)	700 VAC/ 990 VDC	Yes
IPBT/IPBS	.165" (4.19 mm)	Black LCP	High Copper Alloy (IPBT) Phosphor Bronze (IPBS)	Sn over 50 μ" (1.27 μm) Nickel	-55 °C to +105 °C	9.3 A (2 pins power)	400 VAC/ 566 VDC	Yes

(2.54 mm) .100" PITCH • SHROUDED POWER CONNECTOR SET

IPT1	1	NO. PINS PER ROW	LEAD STYLE	PLATING OPTION	D	TAIL OPTION	OTHER OPTIONS
		05 10 15 20 25 (Standard Sizes)	Specify LEAD STYLE from chart	-L = 10 μ" (0.25 μm) Gold on contact, Matte Tin on tail		Requires -01 Lead Style (Leave blank for Through-hole) -RA = Right-angle -VS = Surface Mount	-A = Alignment Pin (-VS only) (N/A with -LC) -LC = Locking Clip (Manual placement required) (-VS only) (N/A with -A) -K = (6.00 mm) .236" DIA Polyimide film Pick & Place Pad (-VS only) -TR = Tape & Reel (-VS only) -FR = Full Reel Tape & Reel (must order max. quantity per reel; contact Samtec for quantity breaks) (-VS only)

IPT1
Board Mates:
IPS1

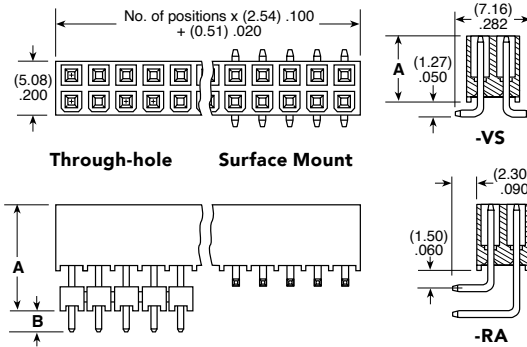
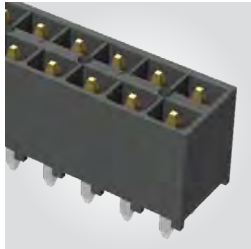

LEAD STYLE	MATED HEIGHT	A	B
-01	(11.05) .435	(6.35) .250	(2.16) .085
-01-VS	(13.59) .535	(6.35) .250	N/A
-02	(14.00) .551	(9.30) .366	(2.64) .104
-03	(16.00) .630	(11.30) .445	(2.16) .085
-04	(17.00) .669	(12.30) .484	(2.69) .106
-05	(19.00) .748	(14.30) .563	(2.46) .097
-06	(20.00) .787	(15.30) .602	(2.35) .093
-07	(25.00) .984	(20.30) .799	(2.31) .091
-08	(30.00) 1.181	(25.30) .996	(2.39) .094
-09	(35.00) 1.378	(30.30) 1.193	(2.46) .097

IPT1/IPS1	
PINS	CURRENT RATING (PER CONTACT)
2	5.9 A
4	4.8 A
6	4.1 A
8	3.6 A
50	2.3 A

IPS1	1	NO. PINS PER ROW	01	PLATING OPTION	D	TAIL OPTION	OTHER OPTIONS
		05 10 15 20 25 (Standard Sizes)		-L = 10 μ" (0.25 μm) Gold on contact, Matte Tin on tail		Leave blank for Through-hole -RA = Right-angle -VS = Surface Mount	-LC = Locking Clip (Manual placement required) (-VS only) -K = (5.50 mm) .217" DIA Polyimide film Pick & Place Pad (-VS only) -TR = Tape & Reel (-VS only) -FR = Full Reel Tape & Reel (must order max. quantity per reel; contact Samtec for quantity breaks) (-VS only)

IPS1
Board Mates:
IPT1

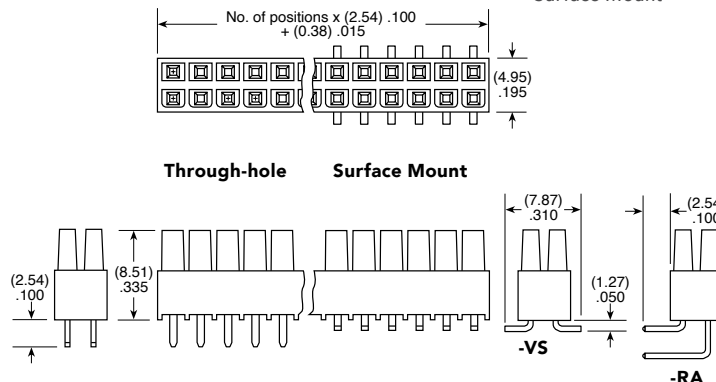
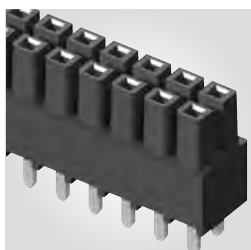

Note:
Some lengths, styles and options are non-standard, non-returnable.

View complete specifications at: samtec.com?IPT1 & samtec.com?IPS1

(4.19 mm) .165" PITCH • ISOLATED POWER CONNECTOR SET

IPBT	1	NO. OF POSITIONS PER ROW	LEAD STYLE	PLATING OPTION	ROW OPTION	OPTIONS
		02, 03, 04, 05, 08, 10 15 (-D Only) (Standard Sizes)	-H1 = Through-hole -H2 = Surface Mount	-T = Matte Tin	-S = Single Row -D = Double Row	-RA = Right-angle (Lead Style -H1 only) -GP = Guide Post Holes (Not available with -K) -K = Keyed Polarization (Not available with -GP option, is required callout if -GP not called out)

IPBT
Board Mates:
IPBS
Cable Mates:
PMMSD, PMSS

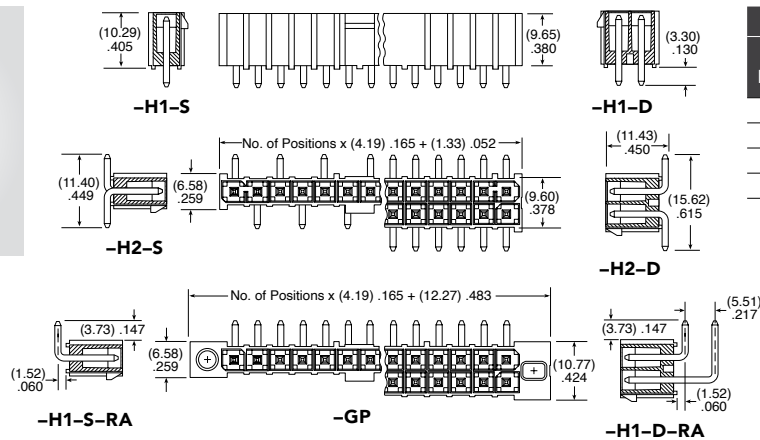
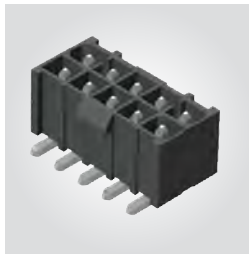

IPBT/IPBS	
PINS POWERED	CURRENT RATING (PER CONTACT)
2	9.3 A
4	7.4 A
6	6.4 A
8	5.9 A
30	4.4 A

IPBS	1	NO. OF POSITIONS PER ROW	LEAD STYLE	PLATING OPTION	ROW OPTION	OPTION
		02, 03, 04, 05, 08, 10 15 (-D Only) (Standard Sizes)	-01 = Standard Power -02 = Standard Power Surface Mount	-T = Matte Tin	-S = Single Row -D = Double Row	-GP = Guide Post

IPBS
Board Mates:
IPBT

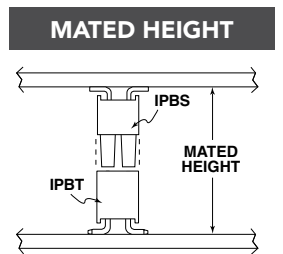
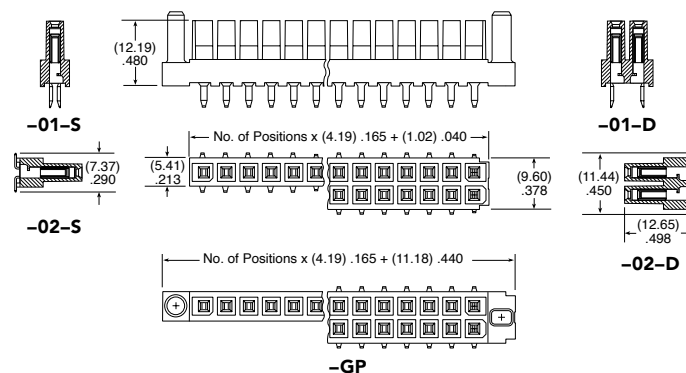
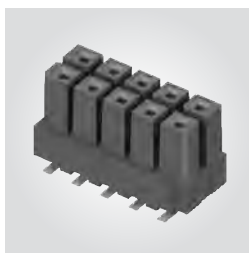

IPBT/IPBS LEAD STYLE	MATED HEIGHT*
H1/-01	(15.25) .600
-H2/-02	(16.84) .663

*Processing conditions will affect mated height.

Note:
Some lengths, styles and options are non-standard, non-returnable.

View complete specifications at: samtec.com?IPBT & samtec.com?IPBS

RUGGED I/O SYSTEMS

POWER I/O • MICRO-HYPERBOLOID CONTACT • SEALED CIRCULARS & RECTANGULARS



ACP/ACR

P1SM/B1SM

B1SDT/P1M

MCP/MCR

RCU/RPBU

ACCLIMATE™

BCU/BPCU/BRU

SCRES/SCPE

226-231

URSA® I/O ULTRA RUGGED POWER CABLE SYSTEMS

Socket Cables and Components (B1SD(T), B1SDS, IBT1, CC508)	227
Panel Mount Terminal Cables and Components (P1PD(T), P1PDS, IPP1, TC145)	228
Board Mount I/O Connector (P1M)	229
SMPM Ganged Cable Assembly (B1SM/P1SM)	230
Ultra Rugged I/O Combinations	231

232-234

FLEXIBLE SEALED SYSTEMS

AccliMate™ IP67 & IP68 Sealed Circular & Rectangular Systems	232-234
--	---------

ULTRA RUGGED I/O SYSTEMS

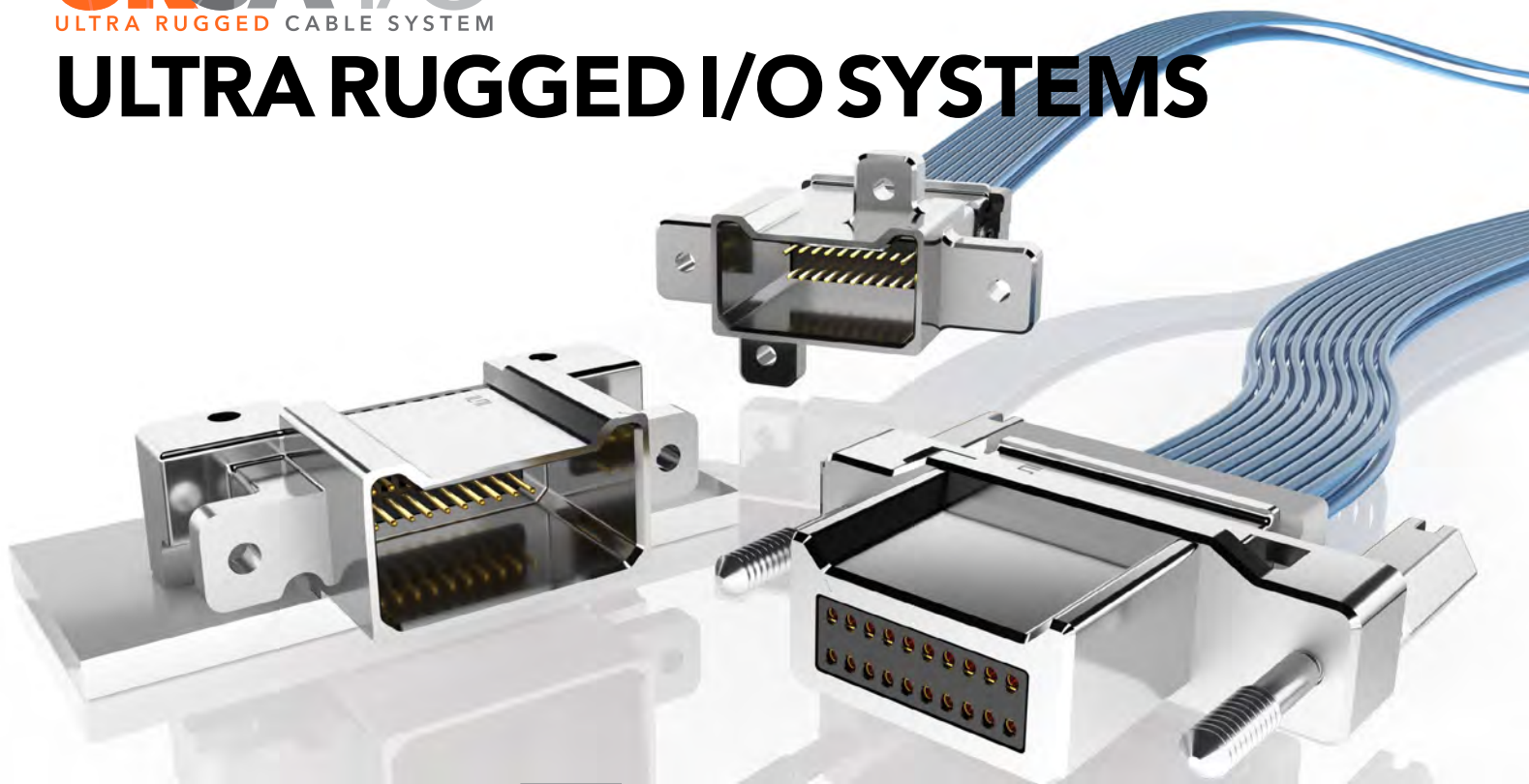

FEATURES & BENEFITS

MAX
3.8
A m p s

- Small form factor
- Four points of contact for a reliable connection and high mating cycles
- Up to 40 positions per row
- Cable-to-cable & cable-to-board solutions
- EMI shielding limits signal degradation and optimizes performance
- Through-hole or surface mount
- 28 & 30 AWG cable
- Availability of contacts (high-speed, RF, power) in 1 to 5 block configurations (See page 231)



Shown actual size at 20 total positions

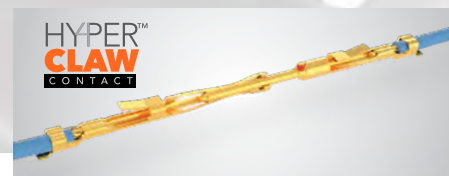

Hyper Claw™ Hyperboloid-type contact for extreme high mating cycles



Extreme density with up to 1,450 total I/Os in a 1RU panel (29 cables at 50 total I/Os each)

KEY SPECIFICATIONS

SERIES	INSULATOR MATERIAL	CONTACT MATERIAL	SHIELD MATERIAL	PLATING	OPERATING TEMP RANGE	CURRENT RATING	VOLTAGE RATING
P1PD(X), B1SD(X), P1M	Liquid Crystal Polymer	Beryllium Copper	Zinc Alloy	Au over 50 μ" (1.27 μm) Ni	-10 °C to +80 °C (PVC) -40 °C to +125 °C (*Teflon™ Fluoropolymer)	3.8 A per pin (2 pins powered)	200 VAC/ 282 VDC
B1SM		Copper Alloy		50 μ" (1.27 μm) Au center contact	Testing Now!	Testing Now!	Testing Now!
P1SM		30 μ" (0.76 μm) Au center contact					

*Teflon™ is a trademark of The Chemours Company FC, LLC used under license by Samtec.

(1.00 mm) .0394" PITCH • NON-PANEL MOUNT I/O CABLE/COMPONENTS

SERIES	NO. OF POSITIONS	WIRE GAUGE	COLOR CODE	PLATING	ASSEMBLED LENGTH	EMI SHIELD	PINOUT
--------	------------------	------------	------------	---------	------------------	------------	--------

B1SD
= Double Row Non-Panel Mount PVC Cable

B1SDT
= Double Row Non-Panel Mount Blue *Teflon™ Fluoropolymer Cable

B1SD
-10, -15, -25, -30
(Per Row)

-28
= 28 AWG

-30
= 30 AWG

(Leave blank for standard wire)

C
= Color Code Wire (Not available with B1SDT)

-H
= 30 μm (0.76 μm) Gold on contact area, Gold flash on tail

-"XX.X"
= Length in inches 06.0" (152.4 mm) minimum

(Leave blank for non-EMI shield)

-E
= EMI Shield (Not available with single ended)

(Leave blank for single ended)

1
= Pin 1 to Pin 1

2
= Pin 1 to Pin 2

3
= Pin 1 to Pin N

4
= Pin 1 to Pin N-1

B1SD PRELIMINARY

B1SD, B1SDT Cable Mates:
P1PD, P1PDT

Board Mates:
P1M

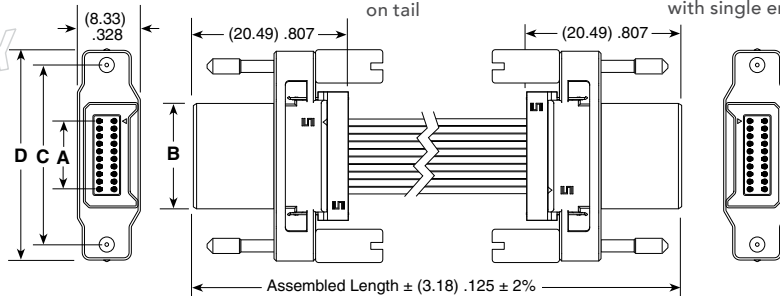

B1SDX-10-XXX-H-XX.X-3 SHOWN

NO. OF POSITIONS	A	B	C	D
-10	(9.00) .354	(13.94) .549	(23.75) .935	(27.75) 1.093
-15	(14.00) .551	(18.94) .746	(28.75) 1.132	(32.75) 1.289
-25	(24.00) .945	(28.94) 1.139	(38.75) 1.526	(42.75) 1.683
-30	(29.00) 1.142	(33.94) 1.336	(43.75) 1.722	(47.75) 1.880

*Teflon™ is a trademark of The Chemours Company FC, LLC used under license by Samtec.

Notes:
Teflon™ Fluoropolymer Cable is intended for crimp only. Contact Samtec for solderable cable applications.

Some lengths, styles and options are non-standard, non-returnable.

B1SD & B1SDT CABLE HOLDER (Required for use with IBT1)

SERIES	NUMBER OF POSITIONS
B1SDR	-10, -15, -25, -30

View complete specifications at: samtec.com?B1SD & samtec.com?B1SDT

B1SDS	NO. OF POSITIONS	N	OPTION
-------	------------------	---	--------

-10, -15, -25, -30

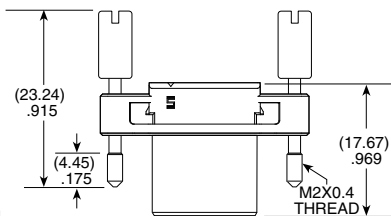
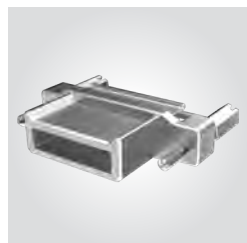

NO. OF POSITIONS	A
-10	(27.75) 1.093
-15	(32.75) 1.289
-25	(42.75) 1.683
-30	(47.75) 1.880

Note:
Some lengths, styles and options are non-standard, non-returnable.

TOOLING

Hand Tool: CAT-HT-508-2830-12 Mini Applicator: CAT-MC-508-2830-XX-03

For more tooling information, visit samtec.com/tooling

IBT1	NO. OF POSITIONS	1
------	------------------	---

-10, -15, -25, -30

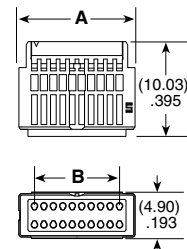

NO. OF POSITIONS	A	B
-10	(12.290) .484	(9.00) .354
-15	(17.290) .681	(14.00) .551
-25	(27.290) 1.074	(24.00) .945
-30	(32.290) 1.271	(29.00) 1.142

CC508	01	PLATING	PACKAGING
-------	----	---------	-----------



-H
= 30 μm (0.76 μm) Gold on contact area, Gold flash on tail

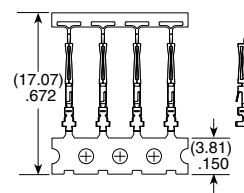

-R
= Full Reel (25,000 Contacts Per Reel)

-M
= Mini Reel (1,000 to 5,000 Contacts Per Reel)

-B
= Bubble Bag (35 Contacts)

View complete specifications at: samtec.com?B1SDS, samtec.com?IBT1 & samtec.com?CC508

(1.00 mm) .0394" PITCH • PANEL MOUNT I/O CABLE/COMPONENTS

SERIES	NO. OF POSITIONS	WIRE GAUGE	COLOR CODE	PLATING	ASSEMBLED LENGTH	END OPTION	PINOUT
--------	------------------	------------	------------	---------	------------------	------------	--------

P1PD
= Double Row Panel Mount PVC Cable

P1PDT
= Double Row Panel Mount Blue *Teflon™ Fluoropolymer Cable

-10, -15, -25, -30
(Per Row)

-28
= 28 AWG

-30
= 30 AWG

(Leave blank for standard wire)

C
= Color Code Wire (Not available with P1PDT)

-H
= 30 μ" (0.76 μm) Gold on contact area, Gold flash on tail

-"XX.X"
= Length in inches 06.0" (152.4 mm) minimum

(Leave blank for single ended)

-B
= B1SD & B1SDT

-S
= SFSD & SFSDT

(Leave blank for single ended)

1
= Pin 1 to Pin 1

2
= Pin 1 to Pin 2

3
= Pin 1 to Pin N

4
= Pin 1 to Pin N-1

P1PD PRELIMINARY

P1PD, P1PDT Cable Mates:
B1SD, B1SDT

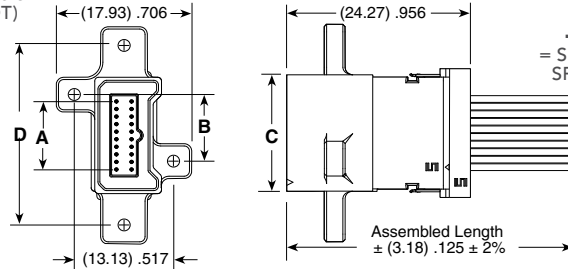
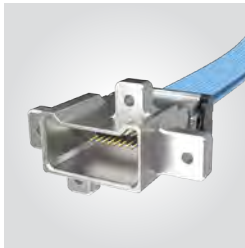

P1PDX-10-XXX-H-XX.X SHOWN

NO. OF POSITIONS	A	B	C	D
-10	(9.00) .354	(8.79) .346	(15.39) .606	(23.75) .935
-15	(14.00) .551	(13.79) .543	(20.39) .803	(28.75) 1.132
-25	(24.00) .945	(23.79) .937	(30.39) 1.196	(38.75) 1.526
-30	(29.00) 1.142	(28.79) 1.133	(35.39) 1.393	(43.75) 1.722

*Teflon™ is a trademark of The Chemours Company FC, LLC used under license by Samtec.

Notes:
Teflon™ Fluoropolymer Cable is intended for crimp only. Contact Samtec for solderable cable applications.

Some lengths, styles and options are non-standard, non-returnable.

P1PD & P1PDT CABLE HOLDER (Required for use with IPP1)

SERIES	NUMBER OF POSITIONS
P1PDR	-10, -15, -25, -30

View complete specifications at: samtec.com?P1PD & samtec.com?P1PDT

P1PDS	NO. OF POSITIONS	N
-------	------------------	---

-10, -15, -25, -30

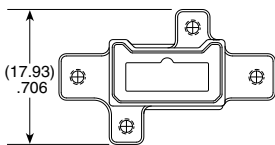
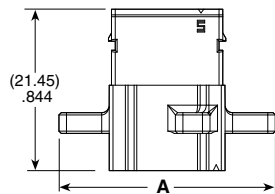
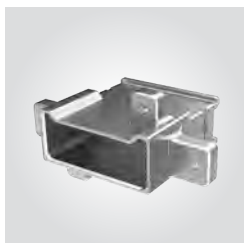

NO. OF POSITIONS	A
-10	(28.75) 1.132
-15	(33.75) 1.329
-25	(43.75) 1.722
-30	(48.75) 1.920

Note:
Some lengths, styles and options are non-standard, non-returnable.

TOOLING

Hand Tool:
CAT-HT-1145-2830-12

Mini Applicator:
CAT-MC-1145-2830-XX-03

For more tooling information, visit samtec.com/tooling

IPP1	NO. OF POSITIONS	1
------	------------------	---

-10, -15, -25, -30

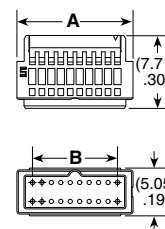

NO. OF POSITIONS	A	B
-10	(12.290) .484	(9.00) .354
-15	(17.290) .681	(14.00) .551
-25	(27.290) 1.074	(24.00) .945
-30	(32.290) 1.271	(29.00) 1.142

TC145	01	PLATING	PACKAGING
-------	----	---------	-----------



-H
= 30 μ" (0.76 μm) Gold on contact area, Gold flash on tail

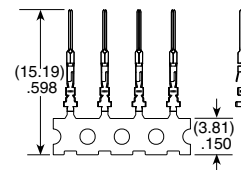

-R
= Full Reel (25,000 Terminals Per Reel)

-M
= Mini Reel (1,000 to 5,000 Terminals Per Reel)

-B
= Bubble Bag (35 Terminals)

View complete specifications at: samtec.com?P1PDS, samtec.com?IPP1 & samtec.com?TC145

(1.00 mm) .0394" PITCH • I/O BOARD MOUNT

P1M	NO. OF POSITIONS	LEAD STYLE	PLATING	D	RA	PIN LENGTH	"X"R
	-10, -15, -25, -30 (Per Row)	-01 = Surface Mount -02 = Through-hole (1.57 mm PCB) -03 = Through-hole (2.36 mm PCB)	-S = 30 μ" (0.76 μm) Gold on contact area, Matte Tin on tail -STL = 30 μ" (0.76 μm) Gold on contact area, Tin/Lead on tail (-01 lead style only)			(Leave blank for standard) -H = Hot Swap	-TR = Tape & Reel -FR = Full Reel Tape & Reel (must order max. quantity per reel; contact Samtec for quantity breaks)

P1M
Cable Mates:
B1SD, B1SDT

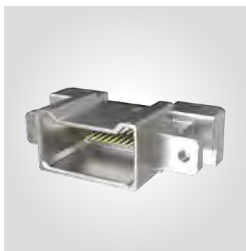

P1M-10-01-S-D-RA SHOWN (SURFACE MOUNT)

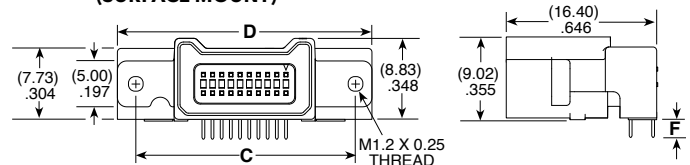

NO. OF POSITIONS	A	B	C	D	E
-10	(9.00) .354	(15.39) .606	(23.75) .935	(27.75) 1.093	(18.80) .740
-15	(14.00) .551	(20.39) .803	(28.75) 1.132	(32.75) 1.289	(23.80) .937
-25	(24.00) .945	(30.39) 1.196	(38.75) 1.526	(42.75) 1.683	(33.80) 1.331
-30	(29.00) 1.142	(35.39) 1.393	(43.75) 1.722	(47.75) 1.880	(38.80) 1.528

LEAD STYLE	F
-02	(1.98) .078
-03	(2.82) .111

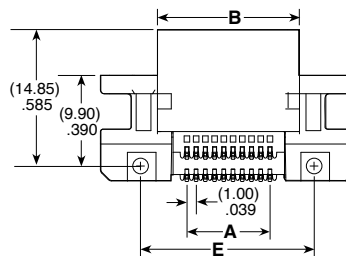

P1M-10-02-S-D-RA SHOWN (THROUGH-HOLE)

Note:
Some lengths, styles and options are non-standard, non-returnable.

View complete specifications at: samtec.com?P1M

P1M	NO. OF POSITIONS	LEAD STYLE	PLATING	DV	PIN LENGTH	PICK & PLACE OPTION	"X"R
	-10, -15, -25, -30 (Per Row)	-01 = Surface Mount -02 = Through-hole (1.57 mm PCB) -03 = Through-hole (2.36 mm PCB)	-S = 30 μ" (0.76 μm) Gold on contact area, Matte Tin on tail -STL = 30 μ" (0.76 μm) Gold on contact area, Tin/Lead on tail		(Leave blank for standard) -H = Hot Swap	(Leave blank for no pad) -K = (8.25 mm) .315" DIA Polyimide Film Pick & Place Pad	-TR = Tape & Reel -FR = Full Reel Tape & Reel (must order max. quantity per reel; contact Samtec for quantity breaks)

P1M
Cable Mates:
B1SD, B1SDT

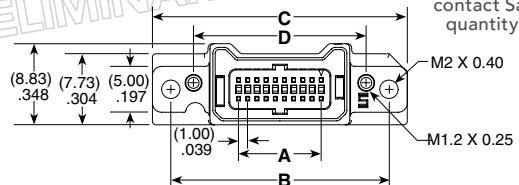

P1M-10-01-S-DV SHOWN

NO. OF POSITIONS	A	B	C	D	E
-10	(9.00) .354	(23.75) .935	(27.75) 1.093	(18.80) .740	(15.22) .599
-15	(14.00) .551	(28.75) 1.132	(32.75) 1.289	(23.80) .937	(20.22) .796
-25	(24.00) .945	(38.75) 1.526	(42.75) 1.683	(33.80) 1.331	(30.22) 1.190
-30	(29.00) 1.142	(43.75) 1.722	(47.75) 1.880	(38.80) 1.528	(35.22) 1.387

Note:
Some lengths, styles and options are non-standard, non-returnable.

View complete specifications at: samtec.com?P1M

SMPM GANGED CABLE ASSEMBLY

B1SM	NO. OF POSITIONS	END 2 CONNECTOR	CABLE LENGTH
	-02, -04, -06	(Refer to RF047-A)	-"XXXX" = Length in millimeters 0100 mm MIN

B1SM
Cable Mates:
P1SM

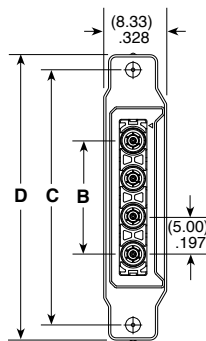

NO. OF POSITIONS	A	B	C	D
-02	(13.94) .354	(5.00) .197	(23.75) .935	(27.75) 1.093
-04	(23.94) .943	(15.00) .594	(33.75) 1.330	(37.75) 1.487
-06	(33.94) 1.337	(25.00) .985	(43.75) 1.724	(47.75) 1.881

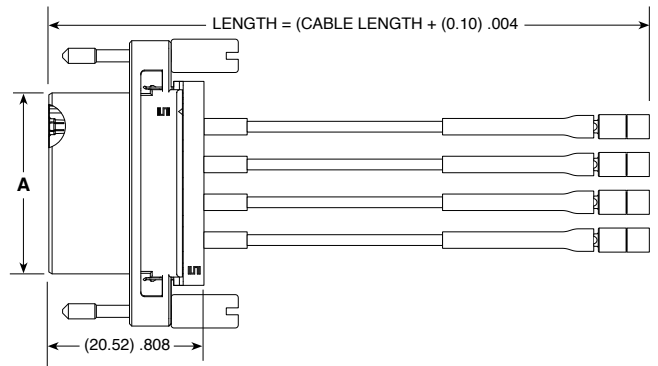

B1SM-04-XXXX-XXXX SHOWN

Notes:
Cable lengths longer than 1000 millimeter are not supported with S.I. test data.

Some sizes, styles and options are non-standard, non-returnable.

View complete specifications at: samtec.com?B1SM

P1SM	NO. OF POSITIONS	END 2 CONNECTOR	CABLE LENGTH
	-02, -04, -06	(Refer to RF047-A)	-"XXXX" = Length in millimeters 0100 mm MIN

P1SM
Cable Mates:
B1SM

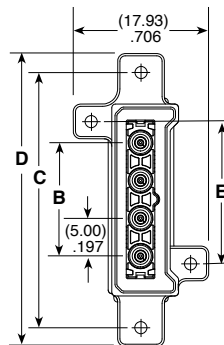
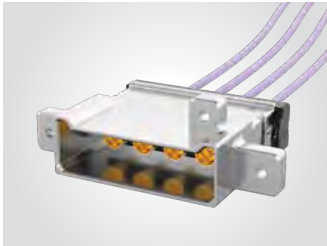

NO. OF POSITIONS	A	B	C	D	E
-02	(15.39) .606	(5.00) .197	(23.75) .936	(25.75) 1.015	(8.79) .346
-04	(25.39) 1.000	(15.00) .591	(33.75) 1.330	(35.75) 1.409	(18.79) .740
-06	(35.39) 1.394	(25.00) .985	(43.75) 1.724	(45.75) 1.803	(28.79) 1.134

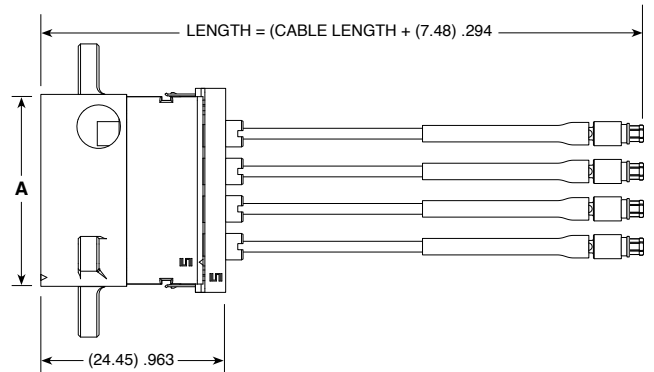

P1SM-04-XXXX-XXXX SHOWN

Notes:
Cable lengths longer than 1000 millimeter are not supported with S.I. test data.

Some sizes, styles and options are non-standard, non-returnable.

View complete specifications at: samtec.com?P1SM

IN DEVELOPMENT: ULTRA RUGGED I/O COMBINATIONS

POWER, RF AND HIGH-SPEED COMBO ASSEMBLIES

FEATURES & BENEFITS

- The ultra rugged features of URSA® I/O combined with a variety of contacts for high-reliability in harsh environments
 - Micro-miniature, push-on SMPM style contacts with frequency to 40 GHz
 - AcceleRate® contacts to 64 Gbps PAM4 performance
 - Hyper Claw™ hyperboloid-style power contacts to 3.8 A max
- Contact combinations in 1, 2, 3, 4 or 5 banks
- Rugged captive panel screws and strain relief
- EMI shielding to limit signal degradation and optimize performance
- 28 and 30 AWG PVC or Teflon™ fluoropolymer wire; color coded available
- For more information, contact RuggedPower@samtec.com

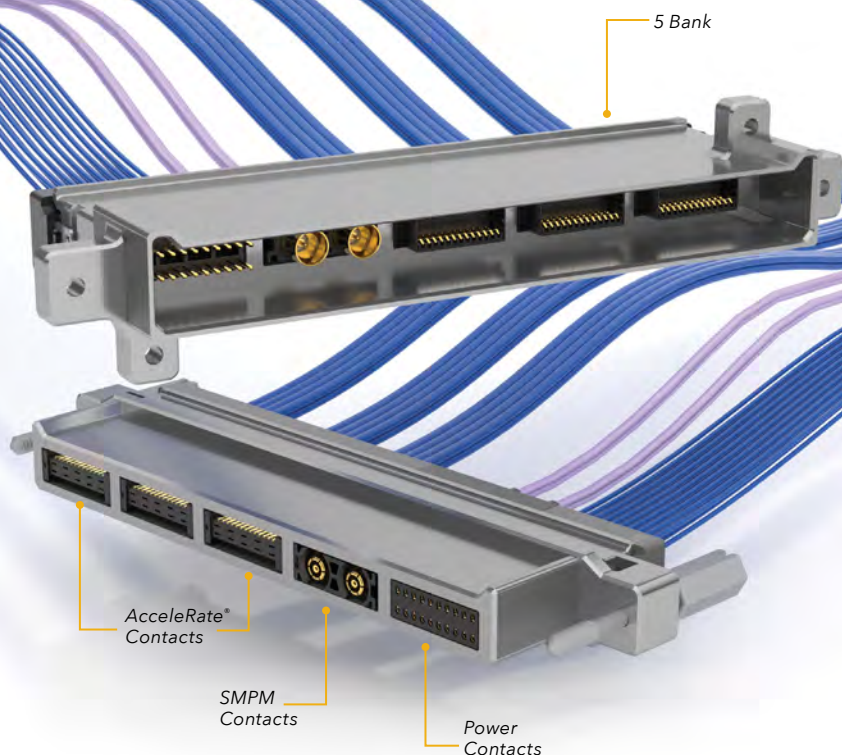

DC TO 40 GHz	PAM 4 64 G b p s	MAX 3.8 A m p s
---------------------------	-------------------------------	------------------------------

CONTACT FLEXIBILITY

Mix and match contact types with any number of housing banks to create a solution for any application.



*Teflon™ is a trademark of The Chemours Company FC, LLC used under license by Samtec.

RUGGED SEALED I/O SYSTEMS



FEATURES & BENEFITS

- Meets IP68 & IP67 requirements for dust and waterproof sealing
- Ideal for high reliability in harsh environments
- Bayonet circulars in 12 mm, 16 mm and 22 mm shell sizes with choice of pin configuration and gender (ACX)
- Lightweight plastic mini push-pull system in a small form factor for increased panel density (MCP/MCR)
- Threaded sealed circular systems available with USB or Ethernet
- Rectangular systems offer a 25-45% panel area savings
- Rugged dust caps available

KEY SPECIFICATIONS

SERIES	TYPE	INSULATOR MATERIAL	TERMINAL MATERIAL	CONTACT MATERIAL	OPERATING TEMP RANGE
ACP-12/ACR-12	Bayonet Circular	Thermoplastic	Brass	Brass/BeCu	-10 °C to +80 °C
ACP-16/ACR-16					-10 °C to +105 °C
ACP-22/ACR-22					-10 °C to +105 °C
MCP/MCR	Mini Push-Pull	PPS	Phosphor Bronze	Phosphor Bronze	-20 °C to +80 °C
BCU/BPCU/BRU	Threaded Circular	Thermoplastic	--	Copper Alloy	-40 °C to +80 °C
SCRUS/SCRES		PBT	--	Phosphor Bronze	-20 °C to +75 °C (SCRUS) -40 °C to +70 °C (SCRES)
RPBE/RPCE		Black LCP (RPBE)	--	Phosphor Bronze	-40 °C to +75 °C
RPBU/RPCU	Rectangular	Glass Filled Thermoplastic (RPCE)	--	Phosphor Bronze	-20 °C to +80 °C
		Black LCP	--	Phosphor Bronze	-20 °C to +80 °C

IP68 SEALED BAYONET CIRCULAR - 12 mm SHELL



Series	Gender	Current Carrying Capacity	Housing	Web Address
ACP-12	Terminal	MAX 5.0 A m p s	Metal or Plastic	samtec.com?acp-12
ACR-12	Socket			samtec.com?acr-12

Kitted components available for field assembly, visit samtec.com/acpk-12 or samtec.com/acrk-12

IP68 SEALED BAYONET CIRCULAR - 16 mm SHELL



Series	Gender	Current Carrying Capacity	Housing	Web Address
ACP-16	Terminal	MAX 11.6 A m p s	Metal or Plastic	samtec.com?acp-16
ACR-16	Socket			samtec.com?acr-16

Kitted components available for field assembly, visit samtec.com/acpk-16 or samtec.com/acrk-16

IP68 SEALED BAYONET CIRCULAR - 22 mm SHELL



Series	Gender	Current Carrying Capacity	Housing	Web Address
ACP-22	Terminal	MAX 8.3 A m p s	Metal or Plastic	samtec.com?acp-22
ACR-22	Socket			samtec.com?acr-22

Kitted components available for field assembly, visit samtec.com/acpk-22 or samtec.com/acrk-22

IP67 SEALED MINI PUSH-PULL - 8 SERIES



Series	Gender	Current Carrying Capacity	Housing	Web Address
MCP	Terminal	MAX 3.4 A m p s	Plastic	samtec.com?mcp
MCR	Socket			samtec.com?mcr

Dust caps: DCA-MCR-8 and DCA-MCP-8

IP67 THREADED CIRCULAR SYSTEM - USB TYPE C



Series	Gender	Current Carrying Capacity	Housing	Web Address
BCU	Terminal (Cable)	Supports 100 W power delivery (5 A @ 20 V)	Plastic	samtec.com?bcu
BPCU	Socket (Cable)			samtec.com?bpcu
BRU	Socket (Board Mount)			samtec.com?bru

Dust cap: DCA-BRU-C-01

IP68 SEALED THREADED CIRCULAR SYSTEM - USB TYPE A/B & ETHERNET



Series	Gender	Current Carrying Capacity	Housing	Mates With	Web Address
SCRUS	Socket (USB)	4.3 Amps MAX	Plastic	SCPU	samtec.com?scrus
SCRES	Socket (Ethernet)	3.8 Amps MAX		SCPE	samtec.com?scres

Dust caps: DCA-17-03, DCA-17-01 and SCPPA-17-01 (panel plug)

IP68 SEALED RECTANGULAR SYSTEM - ETHERNET



Series	Gender	Housing	Mates With	Web Address
RPBE	Socket	Plastic	RCE	samtec.com?rpbe
RPCE	Socket		RCE	samtec.com?rpce

Dust caps: DCA-RPBE-01-01-P (no latch) and DCA-RPBE-XX-01-L (latching)

IP68 SEALED RECTANGULAR SYSTEM - USB TYPE A/B



Series	Gender	Current Carrying Capacity	Housing	Mates With	Web Address
RPBU	Socket	4.5 Amps MAX	Plastic	RCU (Single Port Only)	samtec.com?rpbu
RPCU	Socket			RCU	samtec.com?rpcu

Dust caps: DCA-RPBU-XX-01-X

RUGGED TIGER EYE™ SYSTEMS

HIGH-RELIABILITY • MULTI-FINGER BeCu CONTACT • HIGH MATING CYCLES

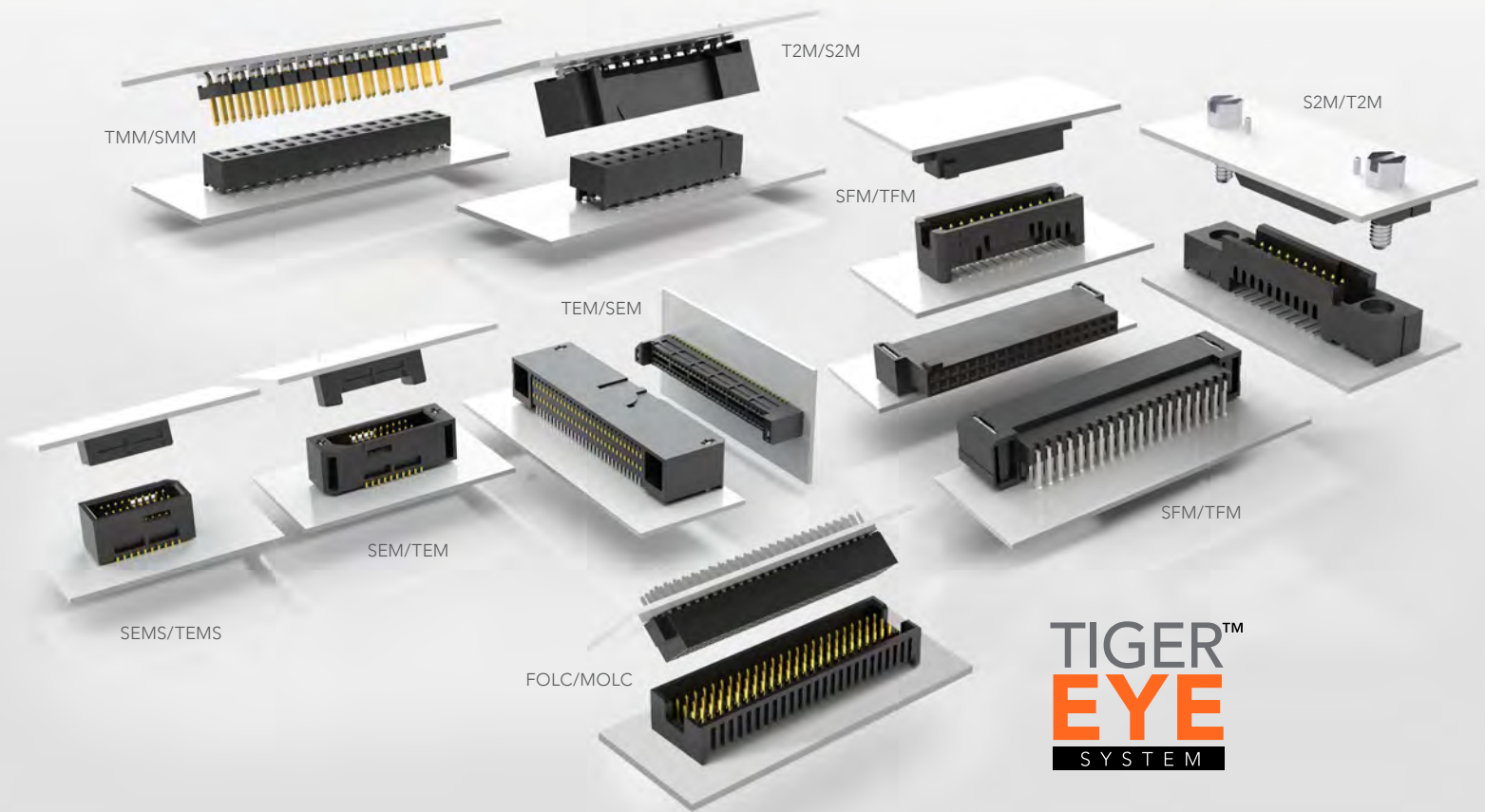

236-241

.050" (1.27 mm) PITCH TIGER EYE™ SYSTEMS

Standard Pitch Sockets & Terminals (SFM, TFM)	236-238
Cost-Effective Tiger Eye™ Lite Sockets & Terminals (SFC, TFC)	239
Quad Row Strips (MOLC, FOLC)	240
Flexible Pin Count Tiger Eye™ Sockets (SFMC)	241

242-243

0.80 mm PITCH TIGER EYE™ SYSTEMS

Micro Pitch Sockets & Terminals (SEM, SEMS, TEM, TEMS)	242-243
--	---------

244-246

2.00 mm PITCH TIGER EYE™ SYSTEMS

2.00 mm Pitch Sockets & Terminals (S2M, T2M)	244-245
2.00 mm Pitch Flex Stack & IDC Cable Socket (SMM)	246

RUGGED TIGER EYE™ SYSTEMS

(1.27 mm) .050" PITCH

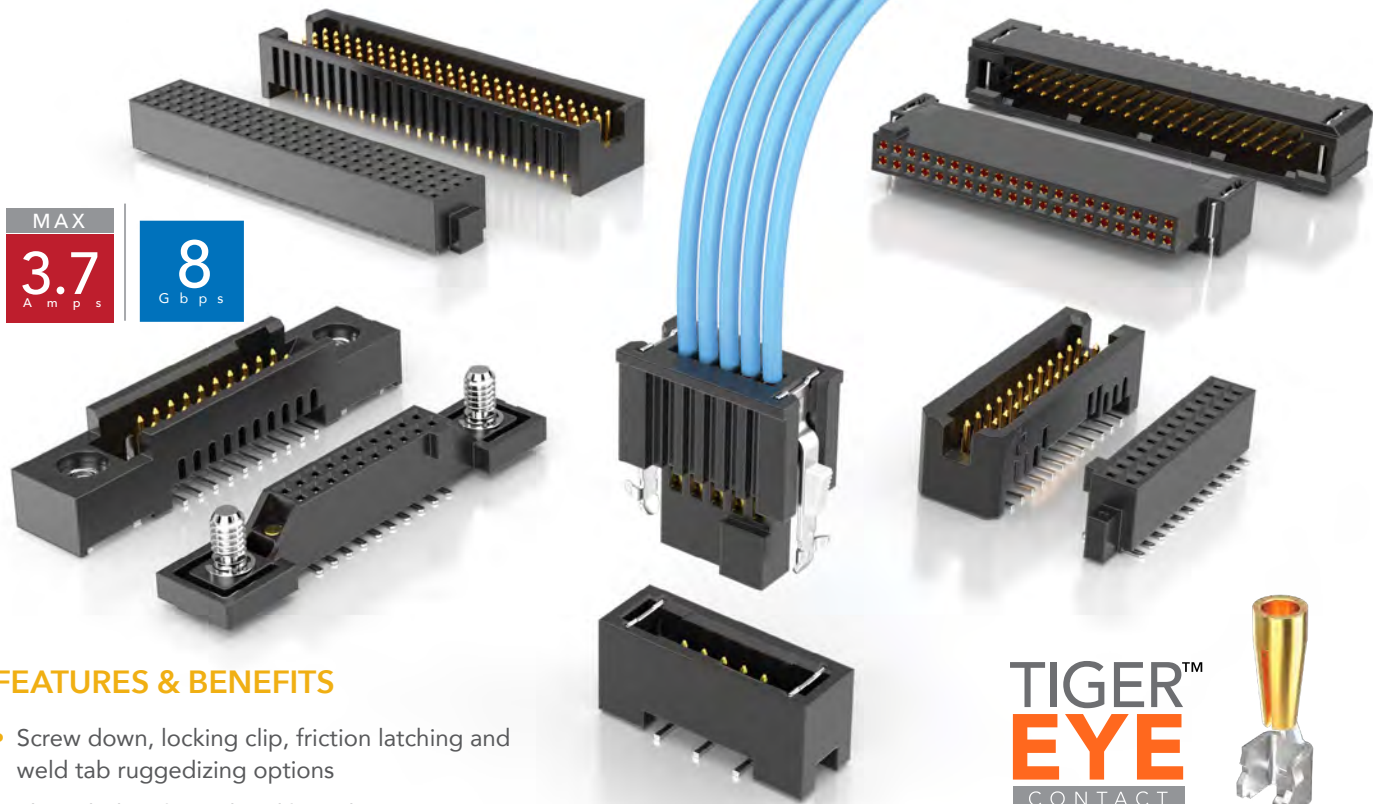

MAX
3.7
A m p s

8
G b p s

FEATURES & BENEFITS

- Screw down, locking clip, friction latching and weld tab ruggedizing options
- Shrouded, polarized and keyed
- Surface mount or through-hole tails
- High-density, four row design (FOLC/MOLC Series)
- Wire to board assemblies available in single or double row, 28 and 30 AWG PVC or *Teflon™ Fluoropolymer (See pages 254-255). Contact asp@samtec.com for custom solutions.
- Cable components (ISDF/CC03) and tooling available: samtec.com/tooling
- Severe Environment Testing qualified (SFM/TFM); aligns with MIL-DTL-55302. Visit samtec.com/set

*Teflon™ is a trademark of The Chemours Company FC, LLC used under license by Samtec.

**TIGER™
EYE**
CONTACT



IDC cable assemblies with rugged strain relief (FFSD/FFMD, FFTP/FMTP)

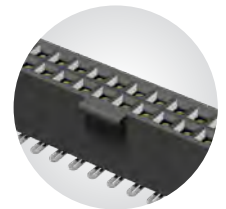

Locking for increased unmating force (SFML/TFML)

KEY SPECIFICATIONS

SERIES	STACK HEIGHTS	INSULATOR MATERIAL	CONTACT MATERIAL	PLATING	OPERATING TEMP RANGE	CURRENT RATING	VOLTAGE RATING	MAX. CYCLES	LEAD-FREE SOLDERABLE
SFM/TFM	6 to 12 mm	Black LCP	BeCu (SFM) Phosphor Bronze (TFM)	Au or Sn over 50 μ" (1.27 μm) Ni	-55 °C to +125 °C	3.7 A per pin (2 pins powered)	250 VAC/ 354 VDC	10,000 with 30 μ" (0.76 μm) Au	Yes
SFC/TFC	6 to 12 mm	Black LCP	Phosphor Bronze	Au or Sn over 50 μ" (1.27 μm) Ni	-55 °C to +125 °C	2.9 A per pin (2 pins powered)	275 VAC/ 389 VDC	(Call Samtec for E.L.P.™ plating option)	Yes

(1.27 mm) .050" PITCH • SMT/THROUGH-HOLE SOCKET

SERIES	1	NO. PINS PER ROW	LEAD STYLE	PLATING OPTION	ROW OPTION	OPTIONS
SFM = Standard		03, 04, 06, 08 (SFM only)	(Surface Mount) (Through-hole) -02 = Tiger Eye™ Contact (BeCu) -L2 = Low Insertion Force Tiger Eye™ Contact (BeCu) -T2 = Tiger Eye™ LITE Contact (Phosphor Bronze)	-F = Gold flash on contact, Matte Tin on tail -L = 10 μ" (0.25 μm) Gold on contact, Matte Tin on tail (Call Samtec for E.L.P.™ plating option)	-S = Single Row (SFM only) -D = Double Row -SH = Single Horizontal (05 thru 30 positions only) (SFM only) (Lead style -02 only) -DH = Double Horizontal (05 thru 30 positions only) (SFM only) (Lead style -02 only)	Specify only -A, -LC or -DS (Not available with -DH, -SH) -A = Alignment Pin -LC = Locking Clip (Manual placement required) -DS = Dual Screw Down for (1.60 mm) .062" PCB (05 thru 40 positions only) (Lead styles -01, -02 & -03 only) (Requires -D row option) (Not available with SFML) (Mates with TFM-DS option) (Not available with -A, -LC, -K, -P, -XR) Specify only -K or -P (Lead styles -02, -L2, -T2 only) -K = Polyimide film Pick & Place Pad (Not available with -DH, -SH) -P = Plastic Pick & Place Pad (Not available with -DH, -SH) Specify -TR or -FR last; Required for -DH & -SH. (Lead styles -02, -L2 & -T2 only) -TR = Tape & Reel -FR = Full Reel Tape & Reel (must order max. quantity per reel; contact Samtec for quantity breaks)
SFML = Locking		05, 07, 10, 15, 20, 25, 30, 35, 40, 45, 50 (Standard sizes)	-01, -03 = Tiger Eye™ Contact (BeCu) -L1, -L3 = Low Insertion Force Tiger Eye™ Contact (BeCu) -T1 = Tiger Eye™ LITE Contact (Phosphor Bronze)			

SFM
Board Mates:
TFM
Cable Mates:
TFSD, TFSS

SFML
Board Mates:
TFML
Cable Mates:
TFSD

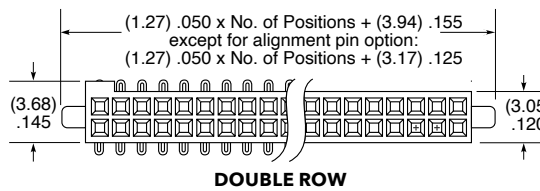
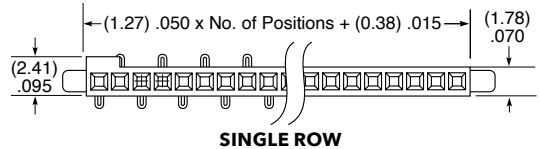
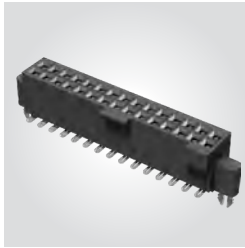

LEAD STYLE	A	B
-01, -L1, -T1	(3.05) .120	(0.51) .020
-03, -L3	(1.91) .075	(0.41) .016

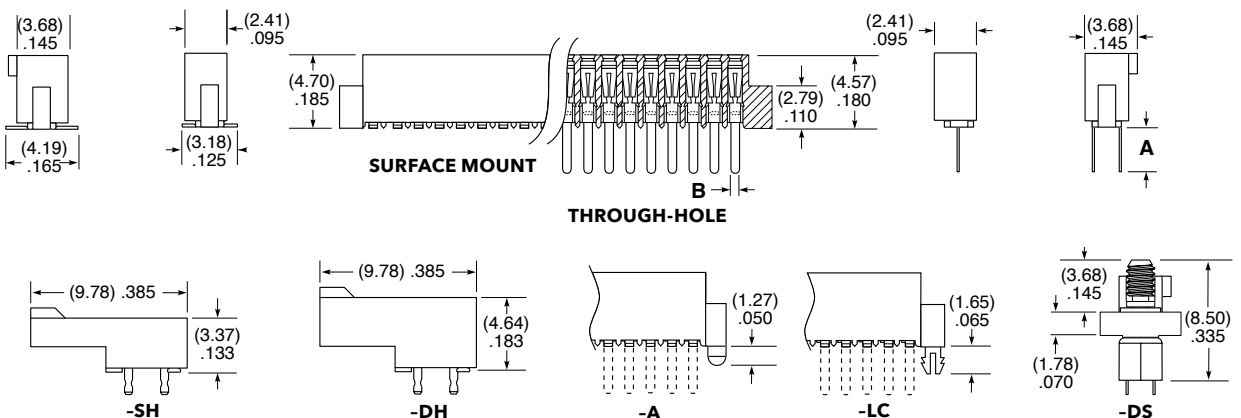

Notes:
Severe Environment Testing qualified (SFM); aligns with MIL-DTL-55302. Visit samtec.com/set

Some lengths, styles and options are non-standard, non-returnable.

View complete specifications at: samtec.com?SFM & samtec.com?SFML

(1.27 mm) .050" • SMT/THROUGH-HOLE HEADER

SERIES	1	NO. PINS PER ROW	LEAD STYLE	PLATING OPTION	ROW OPTION	OPTIONS
--------	---	------------------	------------	----------------	------------	---------

TFM
= Standard

TFML
= Locking
(-01 & -02 lead style only)

03, 04, 06, 08
(TFM -01 & -02 only)

05, 07, 10, 15, 20, 25, 30, 35, 40, 45, 50
(Standard sizes)

Specify **LEAD STYLE** from chart

-F
= Gold flash on contact, Matte Tin on tail

-L
= 15 μm (0.38 μm)
Gold on post, Matte Tin on tail (Call Samtec for E.L.P.™ plating option)

-S
= Single Row (TFM only)

-D
= Double Row

-DH*
= Double Horizontal (TFM lead style -02 only) (05 thru 50 positions only) (-TR or -FR option only available)

Specify only -RA, -RE1 or -RE2

-RA
= Right-angle (Lead style -01 only)

-RE1
= Right-angle Elevated for (1.60 mm) .062" PCB (Requires TFM lead style -01, -D row and -WT)

-RE2
= Right-angle Elevated for (2.36 mm) .093" PCB (Requires TFM lead style -01, -D row and -WT)

Specify only -A, -LC, -DS or -WT
Not available with -RA, -RE1 and -RE2 unless otherwise noted.

-A
= Alignment Pin

-LC
= Locking Clip (Manual Placement required)

-DS
= Dual Screw Down for (1.60 mm) .062" PCB (05, 07, 10, 15, 20, 25, 30, 35, 40 positions only) (TFM lead styles -01 and -02 only) (Requires -D row option) (Mates with SFM-DS option and SFSD/SFSDT -SS and -DS option only) (Not available with -A, -LC, -WT, -K, -P, -XR)

SMT lead styles only
Specify only -K or -P

-K
= Polyimide Film Pick & Place Pad

-P
= Plastic Pick & Place Pad (5 positions min.) (Not available with 5 position with -WT)

Specify -TR or -FR last (Not available with -DS)

-TR
= Tape & Reel

-FR
= Full Reel Tape & Reel (must order max. quantity per reel; contact Samtec for quantity breaks)

TFM

Board Mates: SFM, SFMC
Cable Mates: SFSD, SFSS



TFML

Board Mates: SFML
Cable Mates: SFSD, TFSD, TFSD (-T end option)

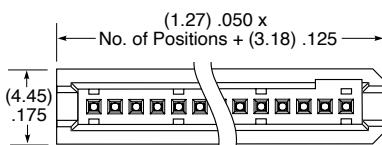

SINGLE ROW

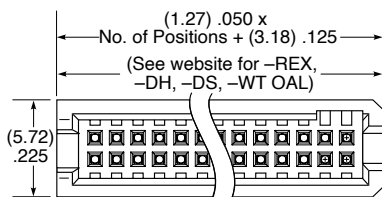

DOUBLE ROW

MATED HEIGHTS*		
LEAD STYLE (SMT)		MATED HEIGHT*
TFM	SFM	
-02	-02	(6.35) .250
-12		(8.13) .320
-22		(9.91) .390
-32		(11.81) .465
LEAD STYLE (T/H)		MATED HEIGHT*
TFM	SFM	
-01	-01	(5.97) .235
-03		(5.97) .235
-11		(7.75) .305
-13		(7.75) .305
-21		(9.53) .375
-23		(9.53) .375
-31		(11.43) .450

*Processing conditions will affect mated height.

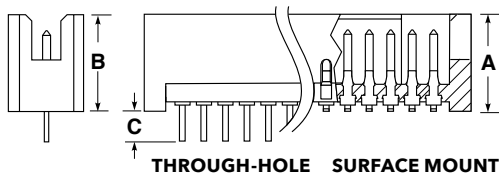

THROUGH-HOLE SURFACE MOUNT

LEAD STYLE (SMT)	A
-02	(5.72) .225
-12*	(7.49) .295
-22*	(9.27) .365
-32*	(11.18) .440

* N/A with 07, -DH or -S row option

LEAD STYLE (T/H)	B	C
-01	(5.59) .220	(1.97) .078
-03*	(5.59) .220	(2.77) .109
-11*	(7.37) .290	(1.97) .078
-13*	(7.37) .290	(2.77) .109
-21*	(9.14) .360	(1.97) .078
-23*	(9.14) .360	(2.77) .109
-31*	(11.05) .435	(1.97) .078

* Not Available with 07 or -S row option

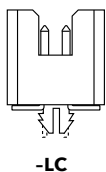

-LC

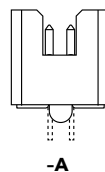

-A

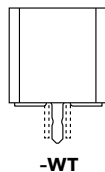

-WT

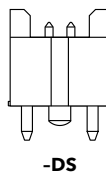

-DS

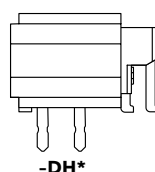

-DH*

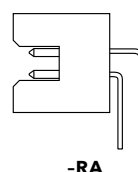

-RA

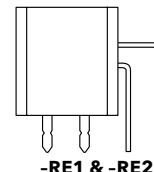

-RE1 & -RE2

Notes:

Severe Environment Testing qualified (TFM); aligns with MIL-DTL-55302. Visit samtec.com/set

Some lengths, styles and options are non-standard, non-returnable.

View complete specifications at: samtec.com?TFM & samtec.com?TFML

(1.27 mm) .050" PITCH • COST-EFFECTIVE HEADER/SOCKET

SFC	1	NO. PINS PER ROW	LEAD STYLE	PLATING OPTION	D	OPTIONS
		04, 05, 10, 15, 20, 25, 30, 35, 40, 45, 50 (Standard sizes)	-T1 = Through-hole Tiger Eye™ LITE -T2 = Surface Mount Tiger Eye™ LITE	-F = Gold flash on contact, Matte Tin on tail -L = 10 μ" (0.25 μm) Gold on contact, Matte Tin on tail		-A = Alignment Pin -K = (4.00 mm) .157" DIA Polyimide film Pick & Place Pad -TR = Tape & Reel (-T2 only) -FR = Full Reel Tape & Reel (must order max. quantity per reel; contact Samtec for quantity breaks) (-T2 only)

SFC
Board Mates:
TFC
Cable Mates:
TFS, TFSDT

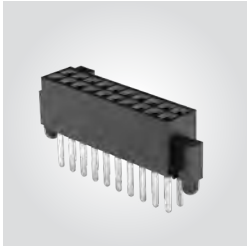
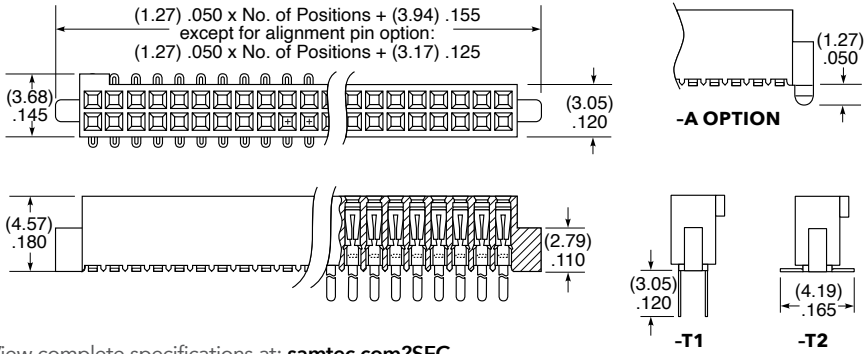
View complete specifications at: samtec.com?SFC

TFC	1	NO. PINS PER ROW	LEAD STYLE	PLATING OPTION	D	OPTIONS
		03, 04, 06, 08 (Lead Style -01 & -02 only) 05, 07, 10, 15, 20, 25, 30, 35, 40, 45, 50 (Standard sizes)	-X1 = Through-hole -X2 = Surface Mount	-F = Gold flash on post, Matte Tin on tail -L = 15 μ" (0.38 μm) Gold on post, Matte Tin on tail		-RA = Right-angle (-01 only) -A = Alignment Pin -LC = Locking Clip (Manual Placement required) (not available with -RA) -K = (6.75 mm) .266" DIA Polyimide film Pick & Place Pad (not available with -RA) -P = Plastic Pick & Place Pad (5 positions min.) (not available with -RA) -TR = Tape & Reel (-X2 only) (not available with -RA) -FR = Full Reel Tape & Reel (must order max. quantity per reel; contact Samtec for quantity breaks) (-X2 only) (not available with -RA)

TFC
Board Mates:
SFC
Cable Mates:
SFS, SFSDT

SMT LEAD STYLE	A	B	TH LEAD STYLE	A	B
-02	(5.72) .225	(3.38) .133	-01	(5.59) .220	(3.38) .133
-12	(7.49) .295		-11	(7.37) .290	
-22	(9.27) .365	(3.30) .130	-21	(9.14) .360	(3.30) .130
-32	(11.18) .440		-31	(11.05) .435	

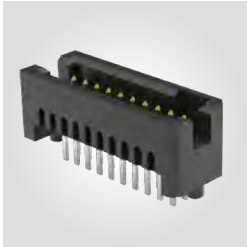
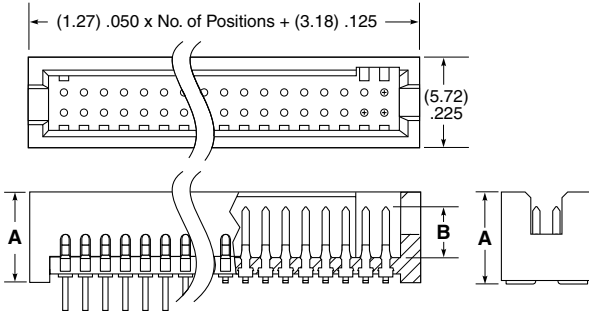
View complete specifications at: samtec.com?TFC

Note:
Some lengths, styles and options are non-standard, non-returnable.

QUAD ROW TERMINAL/SOCKET

(1.27 mm) .050" PITCH • FOLC/MOLC SERIES

MAX
2.6
A m p s

8
G b p s

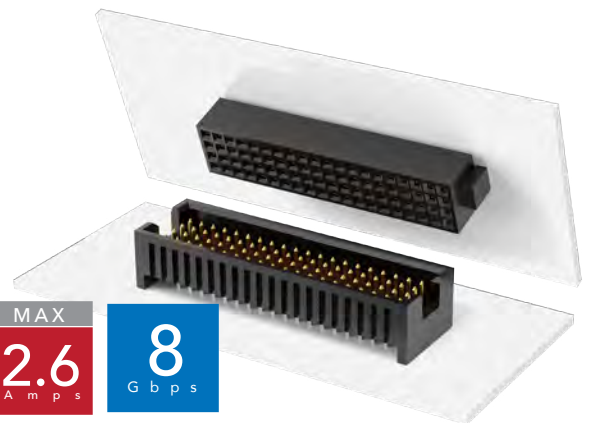

FOLC
Board Mates:
MOLC

MOLC
Board Mates:
FOLC

FOLC	1	NO. PINS PER ROW	LEAD STYLE	PLATING OPTION	Q	OPTION	PACKAGING
------	---	------------------	------------	----------------	---	--------	-----------

20, 25,
30, 35,
40, 45, 50
(Standard sizes)

-01 & -04
= Through-hole

-M1 & -M2
= Mixed Technology

-L1 & -L4
= Low Insertion Force Through-hole

-L
= 10 μm
(0.25 μm)
Gold on contact,
Matte Tin on tail

-LC
= Locking Clip
(Manual placement required)

Leave blank for tubes

-TR
= Tape & Reel
(-MX only)

-FR
= Full Reel Tape & Reel
(must order max. quantity per reel; contact Samtec for quantity breaks)
(-MX only)

SPECIFICATIONS

Insulator Material:
Black Liquid Crystal Polymer

Contact Material (FOLC):
BeCu

Terminal Material (MOLC):
Phosphor Bronze

Plating:
Au or Sn over
50 μm (1.27 μm) Ni

Operating Temp Range:
-55 °C to +125 °C

Current Rating:
2.6 A per pin
(4 pins powered)

Voltage Rating:
165 VAC/233 VDC

Insertion Depth (FOLC):
(3.30 mm) .130" to
(4.06 mm) .160"

Max Cycles (FOLC):
100

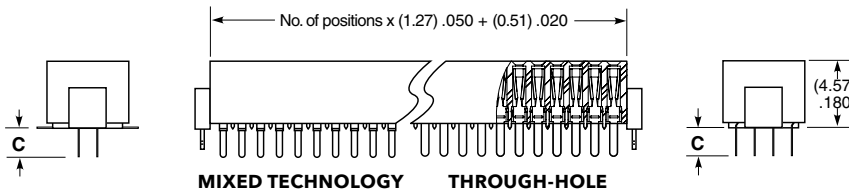
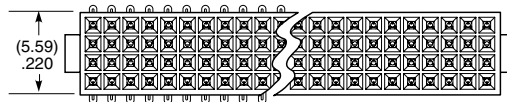

LEAD STYLE	C
-01, -M1	(1.91) .075
-04, -M2	(3.04) .120

View complete specifications at: samtec.com?FOLC

PROCESSING

Lead-Free Solderable:
Yes

SMT Lead Coplanarity (MOLC):
(0.10 mm) .004" max (20-25)
(0.15 mm) .006" max (30-50)*
*(.004" stencil solution may be available; contact ipg@samtec.com)

MOLC	1	NO. PINS PER ROW	LEAD STYLE	PLATING OPTION	Q	OPTION	PACKAGING
------	---	------------------	------------	----------------	---	--------	-----------

20, 25,
30, 35,
40, 45, 50
(Standard sizes)

-'X'1
= Through-hole
(Specify from chart)

-02
= Surface Mount

-M1
= Mixed Technology

-L
= 10 μm
(0.25 μm)
Gold on post,
Matte Tin on tail

-LC
= Locking Clip
(Manual placement required)

-P
= Pick & Place Pad
(-02 only)

Leave blank for tubes

-TR
= Tape & Reel
(-02 & -M1 only)

-FR
= Full Reel Tape & Reel
(must order max. quantity per reel; contact Samtec for quantity breaks)
(-02 & -M1 only)

APPLICATIONS

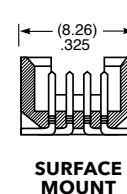
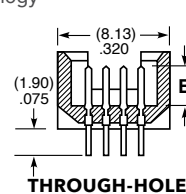
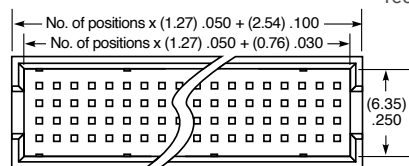
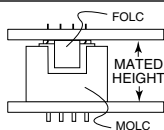

LEAD STYLE		MATED HEIGHT*
MOLC	FOLC	
-01		(5.97) .235
-11	-01	(7.75) .305
-31		(11.43) .450

*Processing conditions will affect mated height.

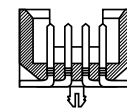
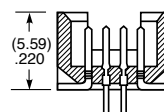
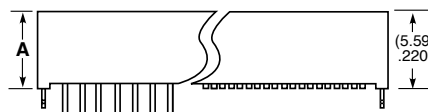

LEAD STYLE	A	B
-01	(5.59) .220	(3.38) .133
-11	(7.34) .289	(3.66) .144
-31	(11.05) .435	

View complete specifications at: samtec.com?MOLC

FLEXIBLE PIN COUNT TIGER EYE™ SOCKET

(1.27 mm) .050" PITCH • SFMC SERIES

MAX
2.9
A m p s

8
G b p s

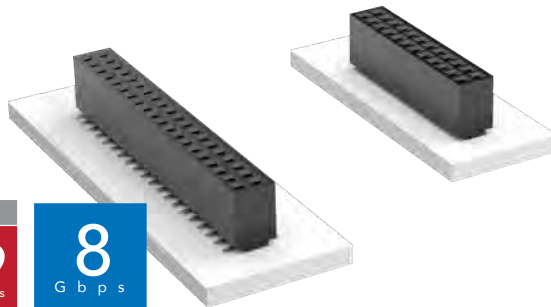

SFMC Board Mates: TFM

Cable Mates:
FMTP, FFMD*

*Note: Standard FFMD callout will not mate with FLE, SFMC. Must use gold plated callouts. (See drawing on web.)

SPECIFICATIONS

Insulator Material:
Black Liquid Crystal Polymer

Contact Material:
Tiger Eye™ = BeCu
Tiger Eye™ LITE =
Phosphor Bronze

Plating:
Au or Sn over
50 μ" (1.27 μm) Ni

Current Rating:
2.9 A per pin
(2 pins powered)

Voltage Rating:
219 VAC/310 VDC

Operating Temp Range:
-55 °C to +125 °C

Insertion Depth:
(3.05 mm) .120" to
(4.06 mm) .160"

Max Cycles:
10,000 with 30 μ" (0.76 μm) Au

PROCESSING

Lead-Free Solderable:
Yes

SMT Lead Coplanarity:
(0.10 mm) .004" max (02-26)
(0.15 mm) .006" max (27-50)*
*(.004" stencil solution
may be available; contact
ipg@samtec.com)

ALSO AVAILABLE
Contact Samtec

Other plating

SFMC	1	NO. PINS PER ROW	LEAD STYLE	PLATING OPTION	D	OPTIONS
		02 thru 50	-01, -03 = Through-hole -L1, -L3 = Low Insertion Force Through-hole -02 = Surface Mount -L2 = Low Insertion Force Surface Mount -T1 = Through-hole Tiger Eye™ LITE -T2 = Surface Mount Tiger Eye™ LITE	-F = Gold flash on contact, Matte Tin on tail -L = 10 μ" (0.25 μm) Gold on contact, Matte Tin on tail		-K = (4.00 mm) .157" DIA Polyimide film Pick & Place Pad (4 positions min.) -P = Plastic Pick & Place Pad (5 positions min.) -TR = Tape & Reel -FR = Full Reel Tape & Reel (must order max. quantity per reel; contact Samtec for quantity breaks)

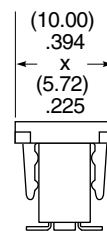
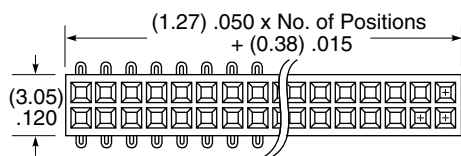

-P OPTION

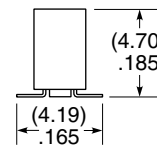
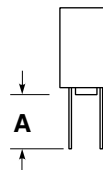
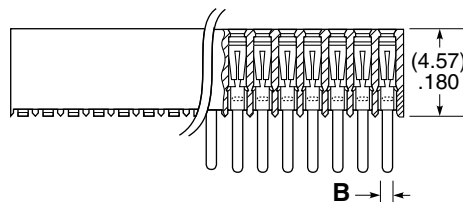

LEAD STYLE	A	B
-01, -L1, -T1	(3.05) .120	(0.51) .020
-03, -L3	(1.91) .075	(0.41) .016

Note:
Some lengths, styles and options are non-standard, non-returnable.

View complete specifications at: samtec.com?SFMC

RUGGED TIGER EYE™ SYSTEMS

(0.80 mm) .0315" PITCH



FEATURES & BENEFITS

- High-reliability, multi-finger BeCu contact
- Micro pitch and slim body for space savings
- 6 mm, 7 mm and 10 mm stack heights
- Locking clip, alignment pins and weld tab ruggedizing features
- Rugged latching system for increased withdrawal force
- Vertical and right-angle mating headers
- Wire to board assembly available with 32 AWG *Teflon™ Fluoropolymer (See page 257). Contact asp@samtec.com for custom solutions.
- Extended Life Product™ testing available

*Teflon™ is a trademark of The Chemours Company FC, LLC used under license by Samtec.

MAX
2.9
A m p s

8
G b p s

**TIGER™
EYE**
CONTACT



Locking for increased unmating force
(Visit samtec.com?SEML for more information)



Components (ISDE/CC396) and tooling available:
samtec.com/tooling

KEY SPECIFICATIONS (SEM/TEM)

STACK HEIGHTS	INSULATOR MATERIAL	CONTACT MATERIAL	PLATING	OPERATING TEMP RANGE	CURRENT RATING	VOLTAGE RATING	MAX. CYCLES	LEAD-FREE SOLDERABLE
6 - 10 mm	Black LCP	BeCu (SEM) Phosphor Bronze (TEM)	Au or Sn over 50 μ" (1.27 μm) Ni	-55 °C to +125 °C	2.9 A per pin (2 pins powered)	235 VAC/332 VDC	100 with 10 μ" (0.25 μm) Au	Yes

(0.80 mm) .0315" PITCH • MICRO TIGER EYE™ SOCKET AND HEADER

SERIES	1	NO. PINS PER ROW	02	STACK HEIGHT	PLATING OPTION	D	OPTIONS	OTHER OPTIONS
SEM Socket		05, 10, 15, 20, 25 (SEM, SEMS, TEM, TEMS only)		-03.0 = 6 mm Stack Height (-03.0 required for SEM/SEMS Series)	-FG = Gold Flash		Leave blank for SEMS/TEMS	-K = (3.50 mm) .138" DIA Polyimide film Pick & Place Pad (Required for SEMS)
SEMS Slim Socket		30, 35, 40, 45, 50 (SEM/TEM only) (Standard sizes)		-04.0 = 7 mm Stack Height (TEM/TEMS only)	-G = 10 μm (0.25 μm) Gold on contact, Gold Flash on tail		-A = Alignment Pin (Not available with -LC or -WT)	= (5.50 mm) .217" DIA Polyimide film Pick & Place Pad (Required for TEMS)
TEM Header				-07.0 = 10 mm Stack Height (TEM/TEMS only)	-H = 30 μm (0.76 μm) Gold on contact, Gold Flash on tail		-LC = Locking Clip (Not available with -A or -WT) (Manual placement required)	-TR = Tape & Reel
TEMS Slim Header							-WT = Weld Tab (Not available with -A or -LC)	-FR = Full Reel Tape & Reel (must order max. quantity per reel; contact Samtec for quantity breaks)

SEM
Board Mates:
TEM

SEMS
Board Mates:
TEMS

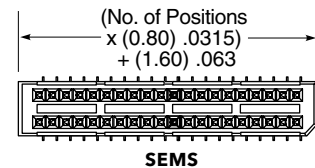
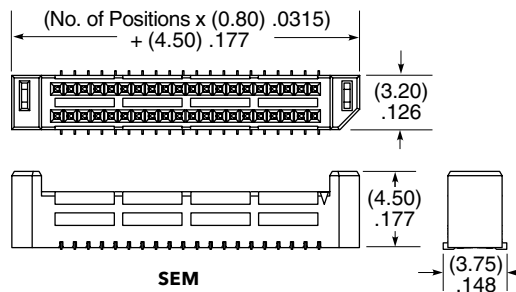

View complete specifications at: samtec.com?SEM & samtec.com?SEMS

TEM
Board Mates:
SEM, SEML

TEMS
Board Mates:
SEMS

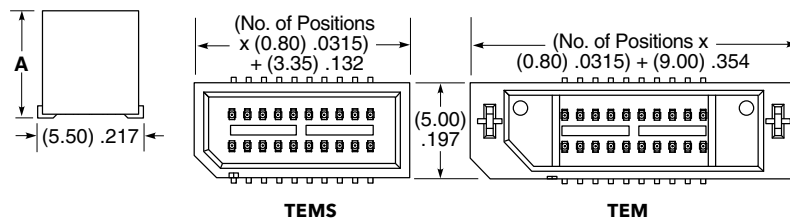

MATED HEIGHTS		
STACK HEIGHT	A	MATED HEIGHT*
-03.0	(5.610) .2209	6 mm
-04.0	(6.610) .2602	7 mm
-07.0	(9.610) .3783	10 mm

*Processing conditions will affect mated height.

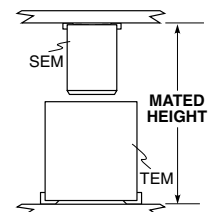

Note:
Some lengths, styles and options are non-standard, non-returnable.

View complete specifications at: samtec.com?TEM & samtec.com?TEMS

RUGGED TIGER EYE™ SYSTEMS

(2.00 mm) .0787" PITCH

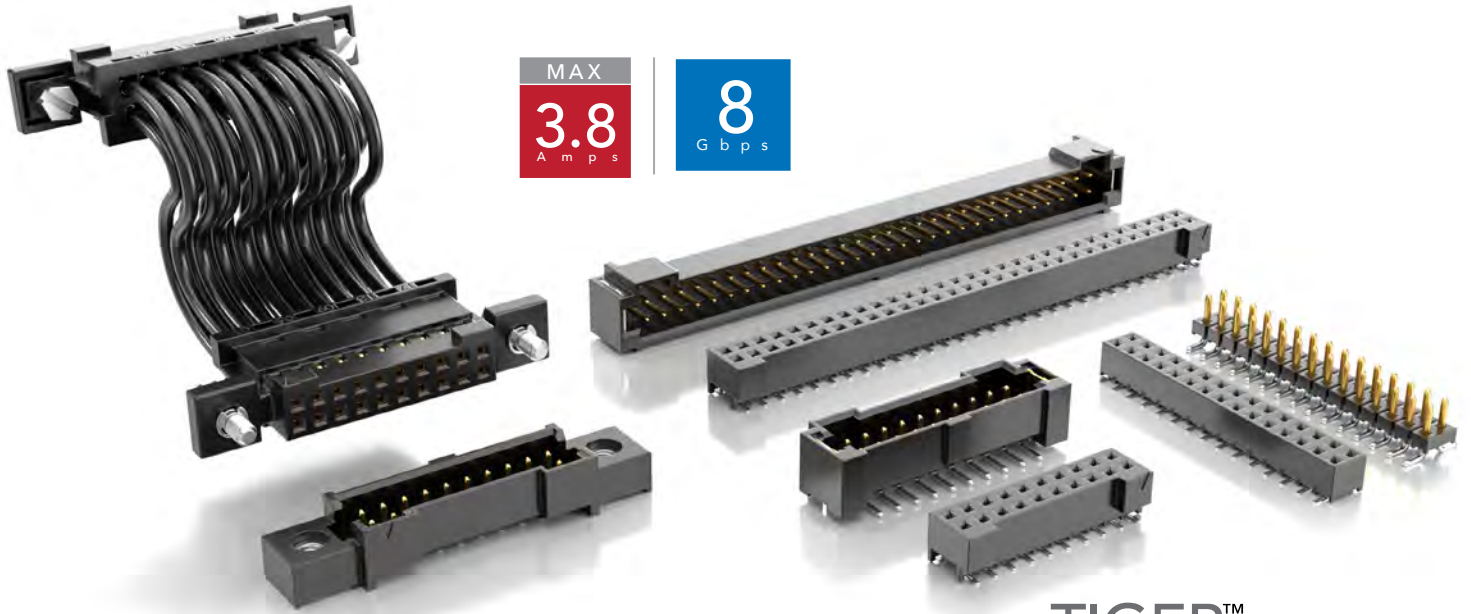

MAX	8
3.8 A m p s	G b p s

FEATURES & BENEFITS

- Rugged Tiger Eye™ contact system for high reliability
- Wide range of stack heights (SMM/TMM Series)
- Right-angle mating headers available
- Optional metal latching, screw downs, weld tabs and locking clips
- Surface mount or through-hole
- Single or double row
- Wire to board assemblies available in 24-30 AWG PVC or *Teflon™ Fluoropolymer (See page 256). Contact asp@samtec.com for custom solutions
- Severe Environment Testing qualified (S2M/T2M); aligns with MIL-DTL-55302. Visit samtec.com/set

*Teflon™ is a trademark of The Chemours Company FC, LLC used under license by Samtec.



Optional strain relief and variety of wiring options



Components (ISD2/CC81) & tooling available: samtec.com/tooling

KEY SPECIFICATIONS (S2M/T2M)

STACK HEIGHTS	INSULATOR MATERIAL	CONTACT MATERIAL	PLATING	OPERATING TEMP RANGE	CURRENT RATING	VOLTAGE RATING	MAX. CYCLES	LEAD-FREE SOLDERABLE
6 & 7 mm	Black LCP	BeCu (S2M) Phosphor Bronze (T2M)	Au or Sn over 50 μ" (1.27 μm) Ni	-55 °C to +125 °C	2.6 A (2 pins powered)	350 VAC/ 495 VDC	100 with 10 μ" (0.25 μm) Au	Yes

(2.00 mm) .0787" PITCH • HIGH-RELIABILITY INTERCONNECTS

SERIES	1	NO. OF POSITIONS	LEAD STYLE	PLATING OPTION	ROW OPTION	OPTIONS	PACKAGING
S2M Socket		(Per Row) 05, 07, 10, 15, 20 25, 30 (Available with -D row option only)	-01 = Through-hole -02 = Surface Mount	-F = Gold flash on contact, Matte Tin on tail -L = 10 μ" (0.25 μm) Gold on contact, Matte Tin on tail	-D = Double row -S = Single row	-K = (5.50 mm) .217" DIA Polyimide film Pick & Place Pad (-02 only) -LC = Locking Clip (Manual placement required) (-02 only) -DS = Screw Down (N/A with -LC) (mates with -T2M-DS)	Leave blank for tube packaging -TR = Tape & Reel (-02 only) -FR = Full Reel Tape & Reel (must order max. quantity per reel; contact Samtec for quantity breaks) (-02 only)

S2M Board Mates: T2M
Cable Mates: T2SD, T2SDT

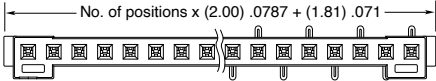
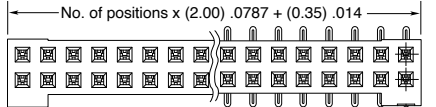
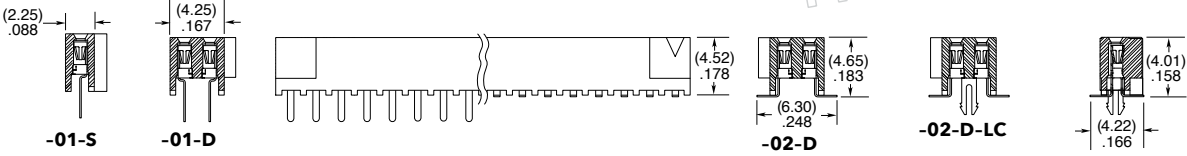





View complete specifications at: samtec.com?S2M

-S-DS PRELIMINARY

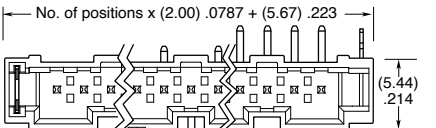
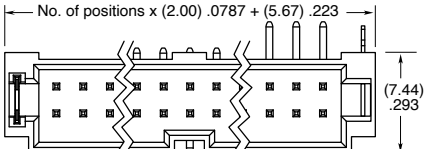
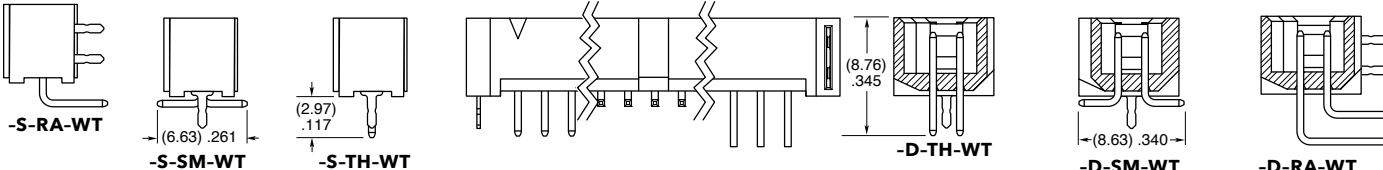
SERIES	1	NO. OF POSITIONS	01	PLATING OPTION	ROW OPTION	TAIL OPTION	OTHER OPTIONS	PACKAGING
T2M Header		(Per Row) 05, 07, 10, 15, 20 25, 30 (Available with -D row option only)		-L = 10 μ" (0.25 μm) Gold on contact, Matte Tin on tail	-D = Double row -S = Single row	-TH = Through-hole -RA = Right-angle -SM = Surface Mount	-WT = Weld Tab (S2SD & S2SDT, -SR/-DR required mate) -DS = Screw Down (N/A with -RA) (mates with -S2M-DS, S2SX/S2SXT -SS/-DS option) -K = (7.50 mm) .295" DIA Polyimide film Pick & Place Pad (-SM only)	Leave blank for tube packaging -TR = Tape & Reel (-SM only) -FR = Full Reel Tape & Reel (must order max. quantity per reel; contact Samtec for quantity breaks) (-SM only)

T2M Board Mates: S2M
Cable Mates: S2SD, S2SDT, S2SS, S2SST







MATED HEIGHT
SM = (7.06 mm) .278"
TH = (6.17 mm) .243"

Note: Some lengths, styles and options are non-standard, non-returnable.

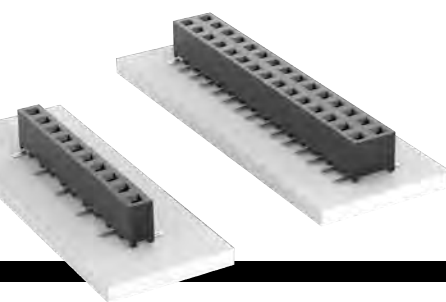
View complete specifications at: samtec.com?T2M

-S-RA & S-DS PRELIMINARY



SMM	1	NO. PINS PER ROW	02	PLATING OPTION	ROW OPTION	OTHER OPTIONS
-----	---	------------------	----	----------------	------------	---------------

02 thru 40

-F
= Gold flash on contact, Matte Tin on tail

-S
= Single Row

-"XX"
= Polarized Position

SMM

Board Mates:

TMM, TMMH, MTMM, MMT, LTMM, TW, PTT, ZLTMM

Cable Mates:

TCMD

-L
= 10 μ" (0.25 μm) Gold on contact, Matte Tin on tail

-D
= Double Row

-K
= (5.50 mm) .217" DIA Polyimide Film Pick & Place Pad (2 positions minimum, -02 thru -05 requires -TR)

-P
= Plastic Pick & Place Pad (-02 thru -05 requires -TR)

-TR
= Tape & Reel Packaging (27 positions maximum)

-FR
= Full Reel Tape & Reel (must order maximum quantity per reel; contact Samtec for quantity breaks) (27 positions maximum)

SPECIFICATIONS

Insulator Material:

Black Liquid Crystal Polymer

Contact Material:

BeCu

Plating: Sn or Au over

50 μ" (1.27 μm) Ni

Current Rating (TMM/SMM):

3.3 A per pin

(2 pins powered)

Voltage Rating:

375 VAC/530 VDC

Operating Temp Range:

-55 °C to +125 °C

Insertion Depth:

(3.05 mm) .120" to

(3.25 mm) .128"

Max Cycles:

100 with 10 μ" (0.25 μm) Au

PROCESSING

Lead-Free Solderable:

Yes

SMT Lead Coplanarity:

(0.10 mm) .004" max

ALSO AVAILABLE

Contact Samtec

Locking Clip

(Manual placement required)

Other platings

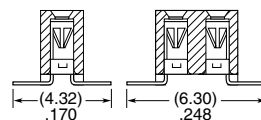
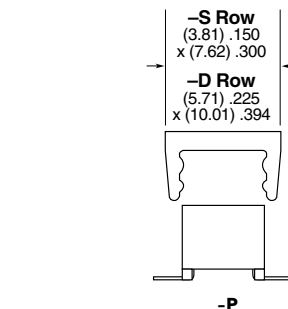
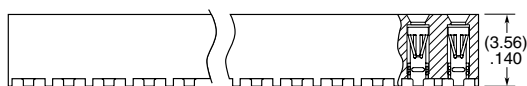
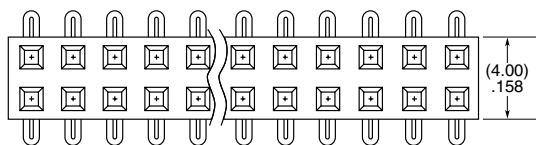
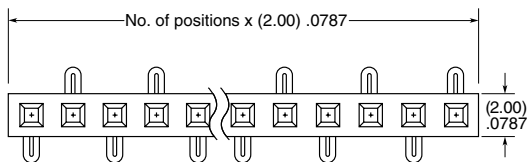

Note:

Some lengths, styles and options are non-standard, non-returnable.

View complete specifications at: samtec.com?SMM

WIRE TO BOARD SYSTEMS

MICRO PITCH • HIGH-CYCLE CONTACTS • ISOLATED POWER • COMPONENTS & TOOLING



248-253

1.00 mm PITCH MICRO MATE™ SYSTEMS

Socket Wire To Board Assemblies/Components (T1M, S1SS(T), S1SD(T), ISS1, ISD1, CC09)	248-251
Single Row Terminal Wire To Board Assemblies/Components (T1SS(T), T1PS(T), IST1, ISP1, TC37)	252
Double Row Terminal Wire To Board Assemblies/Components (T1SD(T), T1PD(T), IDT1, IDP1, TC37)	253

254-258

TIGER EYE™ SYSTEMS

1.27 mm Pitch Socket Wire To Board Assembly/Components (SFSS(T), SFSD(T), ISDF, CC03)	254-255
2.00 mm Pitch Socket Wire To Board Assembly/Components (S2SD(T), S2SS(T), ISD2, CC81)	256
0.80 mm Pitch Socket Wire To Board Assembly/Components (SESdT, ISDE, CC396, TEM)	257-258

259-261

RUGGED POWER SYSTEMS

Power Mate® Wire To Board Assemblies & Components (PMSS(T), PMSD(T), IPBD, CC69)	259
Mini Mate® Wire To Board System (MMSD(T) MMSS(T), IPD1, CC79, IPL1)	260-261

262-264

FLEX POWER SYSTEMS

PowerStrip™/30 Wire To Board Assembly & Components (MPSS, IMS5, CC46)	262
PowerStrip™/30 Signal/Power Combo Wire To Board Assembly & Components (MPCC, IMSC5, CC46, CC81)	263
PowerStrip™/40 Wire To Board Assembly & Components (PESS, IPS6, CC10)	264

MICROMATE™

RUGGED MICRO WIRE TO BOARD SYSTEMS

(1.00 mm) .0394" PITCH

MAX
2.7
A m p s

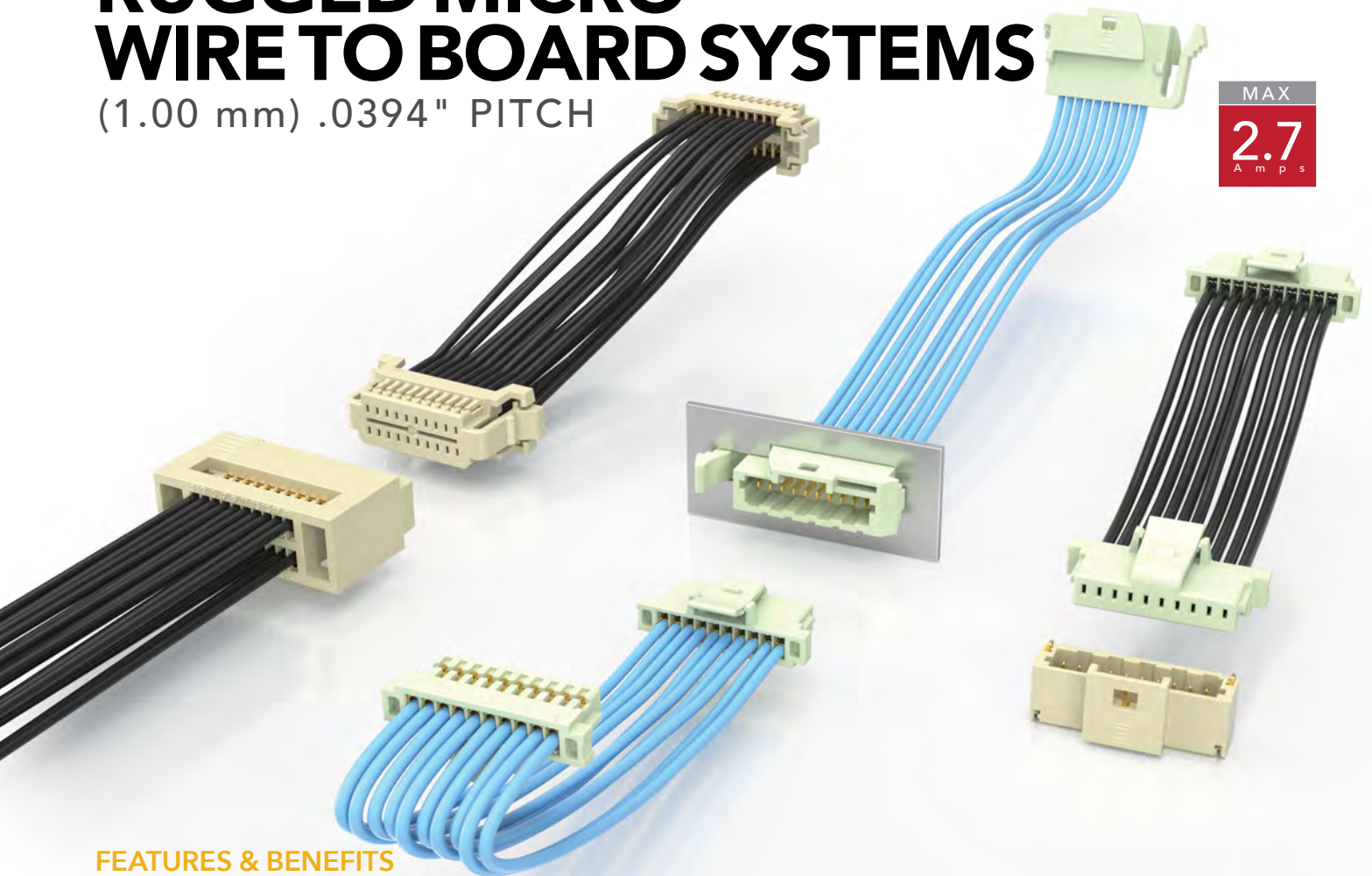

FEATURES & BENEFITS

- Cable-to-cable, panel-to-board and cable-to-board applications
- Extremely small form factors
- 28 and 30 AWG wire options in PVC or Teflon™ Fluoropolymer
- Rugged positive latching for increased retention
- Socket or terminal, single or double row assemblies
- Vertical and right-angle mating headers

Teflon™ is a trademark of The Chemours Company FC, LLC used under license by Samtec.



Dual leaf contact system for a reliable connection

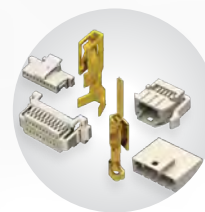

Components and tooling available:
samtec.com/tooling

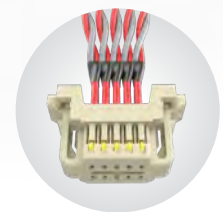

Custom solutions available contact:
asp@samtec.com

KEY SPECIFICATIONS (S1SX(T)/T1M, T1SX(T) & T1PX(T))

PITCH	INSULATOR MATERIAL	CONTACT MATERIAL	PLATING	OPERATING TEMP RANGE
1.00 mm	Black Nylon (S1SS(T) without latch) Natural LCP (T1M) Natural Nylon (S1SD(T), T1XD(T)) Nylon, Light Green (S1SS(T) with latch & T1XS(T))	Phosphor Bronze	Au or Sn over 50 μ" (1.27 μm) Ni	-10 °C to +85 °C (PVC) -40 °C to +125 °C (Teflon™ Fluoropolymer)

(1.00 mm) .0394" PITCH • WIRE TO BOARD TERMINAL

SERIES	NO. OF POSITIONS	PLATING OPTION	ROW OPTION	LATCH	OPTIONS	"X"R
T1M	-02, -03, -05, -07, -10, -15, -20	-F = 3 μ" (0.07 μm) Gold on contact, Matte Tin on tail	-SH = Single Row Horizontal -SV = Single Row Vertical	(Required in callout) -L = Positive Latch	-K = (4.00 mm) .157" DIA Polyimide Film Pick & Place Pad (-SH only) -P = Pick & Place Pad (-SV only)	(Leave blank for Tape & Reel) -FR = Full Reel Tape & Reel (must order max. quantity per reel; contact Samtec for quantity breaks)

T1M-SH/SV
Cable Mates:
S1SS(T)

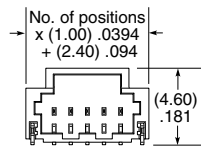
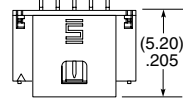
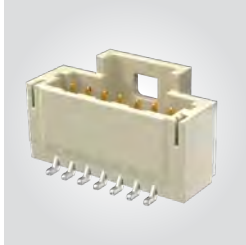

-SH

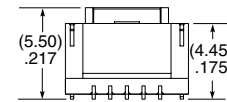
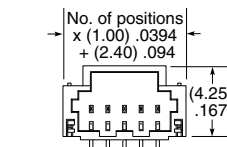
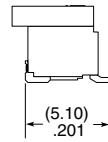

-SV

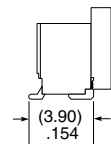

SPECIFICATIONS

Insulator Material:
Natural LCP
Terminal Material:
Phosphor Bronze
Plating: Sn or Au over
50 μ" (1.27 μm) Ni
Operating Temp Range:
-55 °C to +125 °C
(Component only)
Current Rating (T1M/S1SS(T)):
2.2 A per pin
(3 adjacent pins powered)
Voltage Rating:
250 VAC/354 VDC

View complete specifications at: samtec.com?T1M

SERIES	NO. OF POSITIONS	PLATING OPTION	ROW OPTION	OPTION	"X"R
T1M	-02, -03, -04, -05, -10, -15, -20 (Per Row)	-GF = 3 μ" (0.07 μm) Gold contact and tail	-DH = Double Row Horizontal -DV = Double Row Vertical	-K = (4.00 mm) .157" DIA Polyimide Film Pick & Place Pad (-DV only)	(Leave blank for Tape & Reel) -FR = Full Reel Tape & Reel (must order max. quantity per reel; contact Samtec for quantity breaks)

T1M-DH/DV
Cable Mates:
S1SD(T)

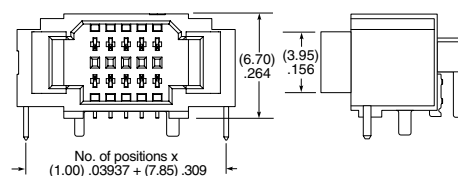
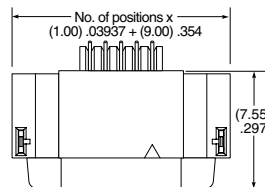
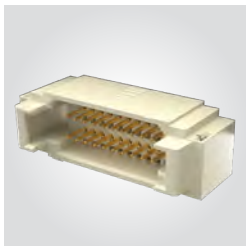

-DH

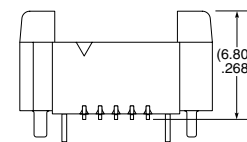
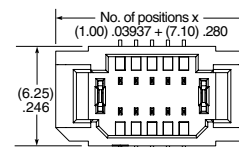

-DV

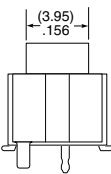

SPECIFICATIONS

Insulator Material:
Natural LCP
Terminal Material:
Phosphor Bronze
Plating: Sn or Au over
50 μ" (1.27 μm) Ni
Operating Temp Range:
-55 °C to +125 °C
(Component only)
Current Rating (T1M/S1SD):
2.5 A per pin
(2 pins powered)
Voltage Rating: 250 VAC/354 VDC

View complete specifications at: samtec.com?T1M

Note:
Some lengths, styles and options
are non-standard, non-returnable.

(1.00 mm) .0394" PITCH • SINGLE ROW WIRE TO BOARD SOCKET



SERIES	PINS PER ROW	WIRE GAUGE	PLATING OPTION	ASSEMBLED LENGTH	OPTION
S1SS = Single Row PVC Cable	-02, -03, -05, -07, -10 -15, -20 (Standard sizes)	-28 = 28 AWG -28C = 28 AWG Color Coded Cable (S1SS only)	-GF = 3 μ" (0.07 μm) Gold on contact and tail	-"XX.XX" = Assembled Length in Inches (45.72 mm) 01.80" min.	(Required Callout) -L = Single Ended With Latch -L1 = Double Ended Latch down, straight (Pin 1 to Pin 1) -L3 = Double Ended Latch up, straight (Pin 1 to Pin N) -S = Single Ended No Latch -D-NUS = Double Ended No Latch, "N" up, straight -D-NDS = Double Ended No Latch, "N" down, straight

S1SS(T)

Board Mates:

T1M

Cable Mates:

T1SS(T), T1PS(T)

SPECIFICATIONS

Insulator Material:

Nylon, Light Green (with latch)
Nylon, Black (without latch)

Contact Material:

Phosphor Bronze

Plating:

Au over 50 μ" (1.27 μm) Ni

Operating Temp Range (S1SS(T)/T1M):

-10 °C to +85 °C (PVC)
-40 °C to +125 °C

(*Teflon™ Fluoropolymer)

Current Rating (S1SS(T)/T1M):

2.2 A per pin
(3 adjacent pins powered)

Voltage Rating:

250 VAC/354 VDC

Wire:

28 or 30 AWG

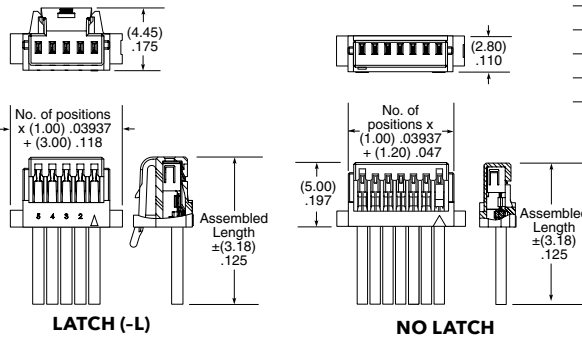



S1SS CABLE COLOR CODING

PIN	COLOR
1	BROWN
2	RED
3	ORANGE
4	YELLOW
5	GREEN
6	BLUE
7	VIOLET
8	GRAY
9	WHITE
10	BLACK
ETC	REPEAT

*Teflon™ is a trademark of The Chemours Company FC, LLC used under license by Samtec.

Note: Teflon™ Fluoropolymer cable is intended for crimp only. Contact Samtec for solderable cable applications.

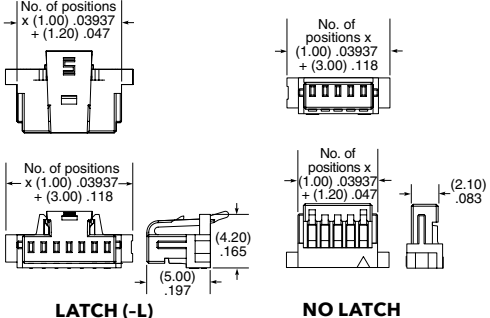
View complete specifications at: samtec.com?S1SS & samtec.com?S1ST

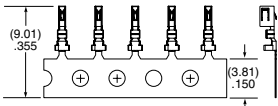
SERIES	NO. OF POSITIONS	LATCH	SERIES	01	PLATING
ISS1 = Single Row Body	-02, -03, -05, -07, -10, -15, -20	(Leave blank for no latch) -L = Positive Latch	CC09R = Contact, Full Reel (25,000 Parts per Reel)		-GF = 3 μ" (0.07 μm) Gold contact and tail
					

TOOLING

Hand Tool: CAT-HT-309-2830-12

Clamp for mounting hand tool: CAT-HT-MNT-01

Mini Applicator: CAT-MC-309-2830-XX-01

Note:

Some lengths, styles and options are non-standard, non-returnable.

View complete specifications at: samtec.com?ISS1, samtec.com?CC09R & samtec.com?CC09M



(1.00 mm) .0394" PITCH • DOUBLE ROW WIRE TO BOARD SOCKET

SERIES	PINS PER ROW	WIRE GAUGE	PLATING OPTION	ASSEMBLED LENGTH	WIRING OPTION
S1SD = Double Row PVC Cable S1SDT = Double Row Blue *Teflon™ Fluoropolymer Cable	-02, -03 -04, -05, -10, -15, -20 (Standard sizes)	-28 = 28 AWG -30 = 30 AWG	-GF = 3 μ" (0.07 μm) Gold on contact and tail	-"XX.XX" = Assembled Length in Inches (45.72 mm) 01.80" min.	Double Ended Assemblies -L1 = Pin 1 to Pin 1 -L2 = Pin 1 to Pin 2 -L3 = Pin 1 to Pin N -L4 = Pin 1 to Pin N-1 Single Ended Assembly -L = Latching

S1SD(T)
Board Mates:
 T1M
Cable Mates:
 T1SD(T), T1PD(T)

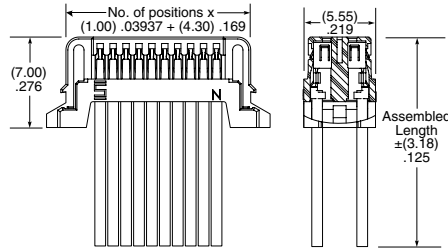
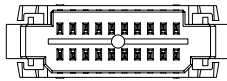



SPECIFICATIONS

Insulator Material:
White Nylon
Contact Material:
Phosphor Bronze
Plating:
Au over 50 μ" (1.27 μm) Ni
Operating Temp Range (S1SD(T)/T1M):
 -10 °C to +85 °C (PVC)
 -40 °C to +125 °C (*Teflon™ Fluoropolymer)
Current Rating (S1SD/T1M):
 2.5 A per pin
 (2 pins powered)
Voltage Rating:
 250 VAC/354 VDC
Wire:
 28 or 30 AWG

*Teflon™ is a trademark of The Chemours Company FC, LLC used under license by Samtec.

Note:
Teflon™ Fluoropolymer cable is intended for crimp only. Contact Samtec for solderable cable applications.

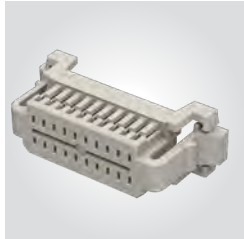
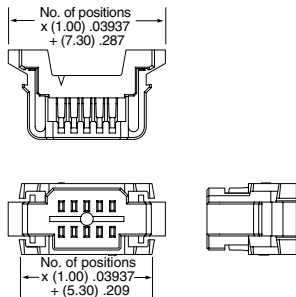
View complete specifications at: samtec.com?S1SD & samtec.com?S1SDT

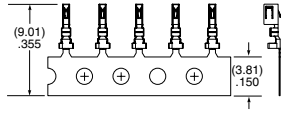
SERIES	NO. OF POSITIONS	SERIES	01	PLATING
ISD1 = Double Row Body	-02, -03, -04, -05, -10, -15, -20 (Per Row)	CC09R = Contact, Full Reel (25,000 Parts per Reel) CC09M = Contact, Mini Reel (5,000 Parts per Reel)		-GF = 3 μ" (0.07 μm) Gold contact and tail
				

TOOLING

Hand Tool: CAT-HT-309-2830-12

Clamp for mounting hand tool: CAT-HT-MNT-01

Mini Applicator: CAT-MC-309-2830-XX-01

Note:
Some lengths, styles and options are non-standard, non-returnable.

View complete specifications at: samtec.com?ISD1, samtec.com?CC09R & samtec.com?CC09M

(1.00 mm) .0394" • SINGLE ROW WIRE TO BOARD TERMINAL

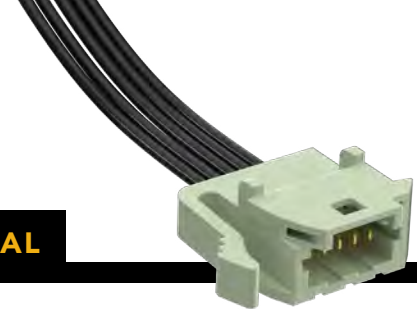

SERIES	NO. OF POSITIONS	WIRE GAUGE	PLATING OPTION	ASSEMBLED LENGTH	PANEL OPTION	PINOUT
T1SS = Single Row Non-Panel Mount PVC Cable T1PS = Single Row Panel Mount PVC Cable T1SST = Single Row Non-Panel Mount Blue *Teflon™ Fluoropolymer Cable T1PST = Double Row Panel Mount Blue *Teflon™ Fluoropolymer Cable	-02 positions not available with T1PS or T1PST) -02 thru -10 (Per Row)	-28 = 28 AWG -28C = 28 AWG Color Coded Cable (T1SS & T1PS only) -30 = 30 AWG -30C = 30 AWG Color Coded Cable (T1SS & T1PS only)	-GF = 3 μ" (0.07 μm) Gold on contact and tail	-"XX.X" = Assembled Length in Inches (45.7 mm) 01.8" min.	(Leave blank for non-panel mount) -A = Fits .033" (0.84 mm), .062" (1.57 mm) and .090" (2.29 mm) Thick Panels	(Leave blank for single ended assembly) -D1 = Double Ended down (Not available with T1PS or T1PST) -D3 = Double Ended up (Not available with T1PS or T1PST)

T1SS(T), T1PS(T)

Cable Mates:

S1SS, S1SST

SPECIFICATIONS

Insulator Material:

Nylon, Light Green

Contact Material:

Phosphor Bronze

Plating:

Au over 50 μ" (1.27 μm) Ni

Operating Temp Range:

-10 °C to +80 °C (PVC)

-40 °C to +125 °C

(*Teflon™ Fluoropolymer)

Current Rating (T1XS/S1SS):

2.7 A per pin

Voltage Rating:

225 VAC/318 VDC

Wire:

28 or 30 AWG

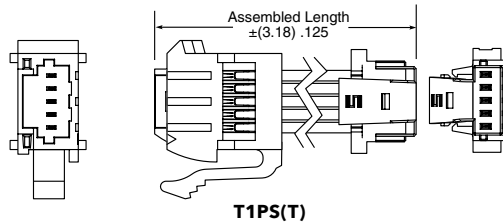
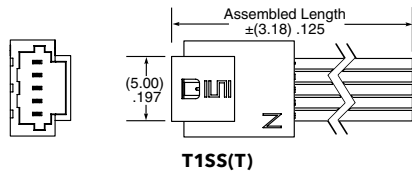

-28C, -30C CABLE COLOR CODING

PIN	COLOR
1	BROWN
2	RED
3	ORANGE
4	YELLOW
5	GREEN
6	BLUE
7	VIOLET
8	GRAY
9	WHITE
10	BLACK
ETC	REPEAT

- T1 = Transfer to socket down
- T3 = Transfer to socket up

*Teflon™ is a trademark of The Chemours Company FC, LLC used under license by Samtec.

Note: Teflon™ Fluoropolymer cable is intended for crimp only. Contact Samtec for solderable cable applications.

View complete specifications at: samtec.com?T1SS, samtec.com?T1SST, samtec.com?T1PS & samtec.com?T1PST

SERIES	NO. OF POSITIONS	PANEL THICKNESS	SERIES	01	PLATING
IST1 = Single Row Body ISP1 = Single Row Panel Mount Body	-02 thru -10 (IST1 Body) -03 thru -10 (ISP1 Body)	(Leave blank for IST1) -A = Fits 0.84 mm, 1.57 mm & 2.29 mm Thick Panels	TC37R = Contact, Full Reel (25,000 Parts per Reel) TC37M = Contact, Mini Reel (1,000 - 5,000 Parts per Reel)		-GF = 3 μ" (0.07 μm) Gold contact and tail

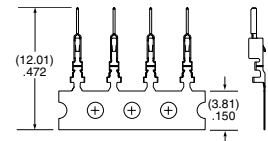
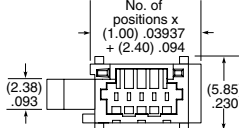
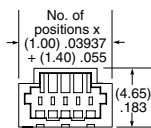

TOOLING

Hand Tool: CAT-HT-1137-2830-12

Mini Applicator: CAT-MC-309-2830-XX-01

Note: Some lengths, styles and options are non-standard, non-returnable.

View complete specifications at: samtec.com?IST1, samtec.com?ISP1, samtec.com?TC37R & samtec.com?TC37M

(1.00 mm) .0394" PITCH • DOUBLE ROW WIRE TO BOARD TERMINAL



SERIES	NO. OF POSITIONS	WIRE GAUGE	PLATING OPTION	ASSEMBLED LENGTH	PANEL OPTION	PINOUT																								
T1SD = Double Row Non-Panel Mount PVC Cable T1PD = Double Row Panel Mount PVC Cable T1SDT = Double Row Non-Panel Mount Blue *Teflon™ Fluoropolymer Cable T1PDT = Double Row Panel Mount Blue *Teflon™ Fluoropolymer Cable T1SD(T), T1PD(T) Cable Mates: S1SD, S1SDT	-02 thru -10 (Per Row)	-28 = 28 AWG -28C = 28 AWG Color Coded Cable (T1SD & T1PD only) -30 = 30 AWG -30C = 30 AWG Color Coded Cable (T1SD & T1PD only)	-GF = 3 μ" (0.07 μm) Gold on contact and tail -28C, -30C CABLE COLOR CODING <table border="1"> <thead> <tr> <th>PIN</th> <th>COLOR</th> </tr> </thead> <tbody> <tr><td>1</td><td>BROWN</td></tr> <tr><td>2</td><td>RED</td></tr> <tr><td>3</td><td>ORANGE</td></tr> <tr><td>4</td><td>YELLOW</td></tr> <tr><td>5</td><td>GREEN</td></tr> <tr><td>6</td><td>BLUE</td></tr> <tr><td>7</td><td>VIOLET</td></tr> <tr><td>8</td><td>GRAY</td></tr> <tr><td>9</td><td>WHITE</td></tr> <tr><td>10</td><td>BLACK</td></tr> <tr><td>ETC</td><td>REPEAT</td></tr> </tbody> </table>	PIN	COLOR	1	BROWN	2	RED	3	ORANGE	4	YELLOW	5	GREEN	6	BLUE	7	VIOLET	8	GRAY	9	WHITE	10	BLACK	ETC	REPEAT	-"XX.X" = Assembled Length in Inches (45.7 mm) 01.8" min.	(Leave blank for non-panel mount) -A = Fits .033" (0.84 mm), .062" (1.57 mm) and .090" (2.29 mm) Thick Panels	(Leave blank for single ended assembly) -D1 = Double Ended down (Not available with T1PD or T1PDT) -D3 = Double Ended up (Not available with T1PD or T1PDT) -T1 = Transfer to socket down -T3 = Transfer to socket up
PIN	COLOR																													
1	BROWN																													
2	RED																													
3	ORANGE																													
4	YELLOW																													
5	GREEN																													
6	BLUE																													
7	VIOLET																													
8	GRAY																													
9	WHITE																													
10	BLACK																													
ETC	REPEAT																													

SPECIFICATIONS

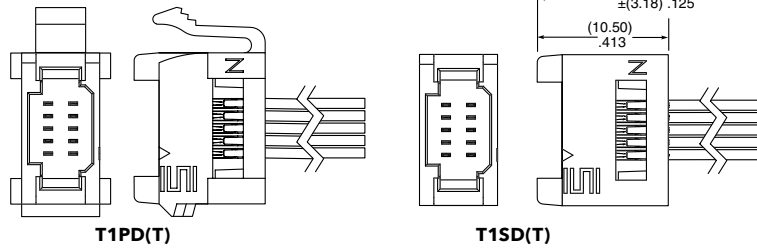

Insulator Material: Nylon, White
Contact Material: Phosphor Bronze
Plating: Au over 50 μ" (1.27 μm) Ni
Operating Temp Range: -10 °C to +80 °C (PVC) -40 °C to +125 °C (*Teflon™ Fluoropolymer)
Current Rating (T1XD/S1SD): 2.7 A per pin (1 pin powered)
Voltage Rating: 225 VAC/318 VDC
Wire: 28 or 30 AWG



*Teflon™ is a trademark of The Chemours Company FC, LLC used under license by Samtec.

Note: Teflon™ Fluoropolymer cable is intended for crimp only. Contact Samtec for solderable cable applications.

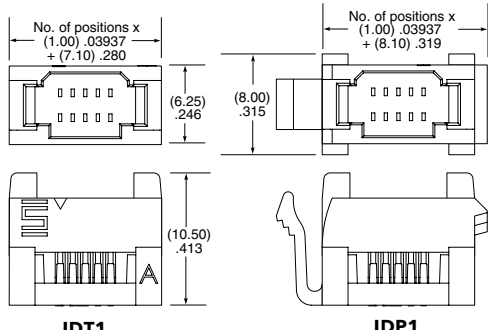
View complete specifications at: samtec.com?T1SD, samtec.com?T1SDT, samtec.com?T1PD & samtec.com?T1PDT

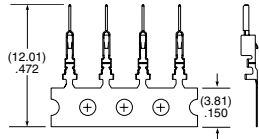
SERIES	NO. OF POSITIONS	PANEL THICKNESS	SERIES	01	PLATING
IDT1 = Double Row Body IDP1 = Double Row Panel Mount Body	-02 thru -10 (per row)	(Leave blank for IDT1) -A = Fits 0.84 mm, 1.57 mm & 2.29 mm Thick Panels	TC37R = Contact, Full Reel (25,000 Parts per Reel) TC37M = Contact, Mini Reel (1,000 - 5,000 Parts per Reel)		-GF = 3 μ" (0.07 μm) Gold contact and tail
					

Note: Some lengths, styles and options are non-standard, non-returnable.

TOOLING

Hand Tool: CAT-HT-1137-2830-12	Mini Applicator: CAT-MC-309-2830-XX-01
--------------------------------	--

View complete specifications at: samtec.com?IDT1, samtec.com?IDP1, samtec.com?TC37R & samtec.com?TC37M

(1.27 mm) .050" PITCH • WIRE TO BOARD ASSEMBLY/COMPONENTS

SERIES	POSITIONS PER ROW	WIRE GAUGE	PLATING OPTION	ASSEMBLED LENGTH	END OPTION	END 2 OPTION
SFSS = Single Row PVC Cable SFSST = Single Row Blue *Teflon™ Fluoropolymer Cable	-03, -04, -05, -07, -10, -15, -20, -25, -40, -50 (Standard sizes)	-28 = 28 AWG -28C = Color Coded Cable (SFSS only) -30 = 30 AWG	-F = Gold flash on contact and tail -G = 10 μm (0.25 μm) Gold on contact, Gold flash on tail	-"XX.XX" = Assembled Length in Inches (76.20 mm) 03.00" min. for -S end option (82.60 mm) 03.25" min. for -D end option	-S = Single Ended -D = Double Ended -SR = Single Ended Retention Latch (TFM-WT option required for mating) -DR = Double Ended Retention Latch (TFM-WT option required for mating)	Requires -D or -DR (End 1 Notch Up) -NUS = Notch up, straight (Pin 1 to Pin N) -NDS = Notch down, straight (Pin 1 to Pin 1)

SFSS(T) Board Mates:
TFM, TFC
(-SR & -DR requires -WT option)

SPECIFICATIONS

Insulator Material: Black LCP
Contact Material: BeCu
Plating: Au over 50 μm (1.27 μm) Ni
Operating Temp Range: -10 °C to +80 °C (PVC) -40 °C to +125 °C (*Teflon™ Fluoropolymer)
Current Rating: 2.9 A per pin (2 pins powered)
Voltage Rating: 275 VAC/389 VDC
Wire: 28 or 30 AWG

-28C CABLE COLOR CODING	
PIN	COLOR
1	BROWN
2	RED
3	ORANGE
4	YELLOW
5	GREEN
6	VIOLET
7	GRAY
8	WHITE
9	BLACK
10	BLUE
ETC	REPEAT

*Teflon™ is a trademark of The Chemours Company FC, LLC used under license by Samtec.

Notes: Teflon™ Fluoropolymer cable is intended for crimp only. Contact Samtec for solderable cable applications.

For wiring option information refer to drawings on web.

ISDF	POSITIONS PER ROW	ROW OPTION	OPTION	SERIES	WIRE GAUGE	01	PLATING
	-03, -04, -05, -07, -10, -15, -20, -25, -40, -50 (Standard sizes)	-S = Single Row	-M = Metal Retention Latch	CC03R = Contact, Full Reel (35,000 Parts per Reel) CC03M = Contact, Mini Reel (1,000 - 5,000 Parts per Reel)	-2830 = 28 to 30 AWG		-GF = Gold flash contact -G = 10 μm (0.25 μm) Gold on contact

TOOLING

Hand Tool: CAT-HT-203-2830-12	Mini Applicator: CAT-MC-203-2830-XX-01
Clamp for mounting hand tool: CAT-HT-MNT-01	Extraction Tool: CAT-EX-169-01

Note: Some lengths, styles and options are non-standard, non-returnable.

View complete specifications at: samtec.com?ISDF, samtec.com?CC03R & samtec.com?CC03M

(1.27 mm) .050" PITCH • WIRE TO BOARD ASSEMBLY/COMPONENTS



SERIES	POSITIONS PER ROW	WIRE GAUGE	PLATING OPTION	ASSEMBLED LENGTH	END OPTION	END 2 OPTION
SFSD = Double Row PVC Cable SFSDT = Double Row Blue *Teflon™ Fluoropolymer Cable	-03, -04, -05, -07, -10, -15, -20, -25, -40, -50 (Standard sizes)	-28 = 28 AWG -28C = Color Coded Cable (SFSD only) -30 = 30 AWG	-F = Gold flash on contact and on tail -G = 10 μ" (0.25 μm) Gold on contact, Gold Flash on tail	-"XX.XX" = Assembled Length in Inches (76.20 mm) 03.00" min. for -S end option (82.60 mm) 03.25" min. for -D end option	-S = Single Ended -D = Double Ended For -(X) specify "S" for single ended and "D" for double ended. -(X)R = Retention Latch (TFM-WT option required for mating) -(X)S = Screw Down (Not available in -03, -04 & -50 positions) (Mates with TFM-DS option)	Requires -D, -DS, -DR (End 1 Notch Up) -NUS = Notch up, straight (Pin 1 to Pin N-1) -NDS = Notch down, straight (Pin 1 to Pin 2) -NUS = Notch up, crossed (Pin 1 to Pin N) -NDX = Notch down, crossed (Pin 1 to Pin 1)

SFSD(T) Board Mates: TFM, TFML, TFC (-SR & -DR requires -WT option)

SPECIFICATIONS

Insulator Material: Black LCP
Contact Material: BeCu
Plating: Au over 50 μ" (1.27 μm) Ni
Operating Temp Range: -10 °C to +80 °C (PVC) -40 °C to +125 °C (*Teflon™ Fluoropolymer)
Current Rating: 2.9 A per pin (2 pins powered)
Voltage Rating: 275 VAC/389 VDC
Wire: 28 or 30 AWG

-28C CABLE COLOR CODING	
PIN	COLOR
1	BROWN
2	RED
3	ORANGE
4	YELLOW
5	GREEN
6	VIOLET
7	GRAY
8	WHITE
9	BLACK
10	BLUE
ETC	REPEAT

-SR

-D-NUS

SFSD OR SFSDT

*Teflon™ is a trademark of The Chemours Company FC, LLC used under license by Samtec.

Notes: Teflon™ Fluoropolymer cable is intended for crimp only. Contact Samtec for solderable cable applications.

For wiring option information refer to drawings on web.

View complete specifications at: samtec.com?SFSD & samtec.com?SFSdT

ISDF	POSITIONS PER ROW	ROW OPTION	OPTION	SERIES	WIRE GAUGE	01	PLATING
	-03, -04, -05, -07, -10, -15, -20, -25, -40, -50 (Standard sizes)	-D = Double Row	-M = Metal Retention Latch -S = Screw Down	CC03R = Contact, Full Reel (35,000 Parts per Reel) CC03M = Contact, Mini Reel (1,000 - 5,000 Parts per Reel)	-2830 = 28 to 30 AWG		-GF = Gold flash contact -G = 10 μ" (0.25 μm) Gold on contact

-D

-M

-S

TOOLING

Hand Tool: CAT-HT-203-2830-12	Mini Applicator: CAT-MC-203-2830-XX-01
Clamp for mounting hand tool: CAT-HT-MNT-01	Extraction Tool: CAT-EX-169-01

Note: Some lengths, styles and options are non-standard, non-returnable.

View complete specifications at: samtec.com?ISDF, samtec.com?CC03R & samtec.com?CC03M



(2.00 mm) .0787" PITCH • WIRE TO BOARD ASSEMBLY/COMPONENTS

SERIES	PINS PER ROW	WIRE GAUGE	PLATING OPTION	ASSEMBLED LENGTH	END OPTIONS	END 2 OPTIONS																									
S2SD = Double Row PVC Cable	-05, -07, -10, -15, -20 (Standard sizes)	-24	-L = 10 μm (0.25 μm) Gold on contact	-"XX.XX" = Wire Length in Inches (69.85 mm) 02.75" min.	-S = Single End	(Only available with -D, -DR & -DS)																									
S2SDT = Double Row Blue *Teflon™ Fluoropolymer Cable (24, 28, 30 AWG only)	-25, -30 (Available with S2SD & S2SDT only)	-24C = Color Coded Cable (S2SD & S2SS only)			-D = Double End	-NUS = Notch up, straight (Pin 1 to Pin N-1)																									
S2SS = Single Row PVC Cable		-26			Specify "S" for single ended and "D" for double ended.	-NDS = Notch down, straight (Pin 1 to Pin 2)																									
S2SST = Single Row Blue *Teflon™ Fluoropolymer Cable (24, 28, 30 AWG only)		-28			-(X)R = Retention Latch (-SR mates with T2M-WT)	-NUX = Notch up, crossed (Pin 1 to Pin N)																									
S2SD(T)/S2SS(T) Board Mates: T2M		-30			-(X)S = Screw Down (10 positions minimum) (mates with T2M-DS)	-NDX = Notch down, crossed (Pin 1 to Pin 1) (S2SD(T) only)																									
		-24C CABLE COLOR CODING																													
		<table border="1"> <thead> <tr> <th>PIN</th> <th>COLOR</th> </tr> </thead> <tbody> <tr><td>1</td><td>BROWN</td></tr> <tr><td>2</td><td>RED</td></tr> <tr><td>3</td><td>ORANGE</td></tr> <tr><td>4</td><td>YELLOW</td></tr> <tr><td>5</td><td>GREEN</td></tr> <tr><td>6</td><td>VIOLET</td></tr> <tr><td>7</td><td>GRAY</td></tr> <tr><td>8</td><td>WHITE</td></tr> <tr><td>9</td><td>BLACK</td></tr> <tr><td>10</td><td>BLUE</td></tr> <tr><td>ETC</td><td>REPEAT</td></tr> </tbody> </table>	PIN	COLOR	1	BROWN	2	RED	3	ORANGE	4	YELLOW	5	GREEN	6	VIOLET	7	GRAY	8	WHITE	9	BLACK	10	BLUE	ETC	REPEAT					
PIN	COLOR																														
1	BROWN																														
2	RED																														
3	ORANGE																														
4	YELLOW																														
5	GREEN																														
6	VIOLET																														
7	GRAY																														
8	WHITE																														
9	BLACK																														
10	BLUE																														
ETC	REPEAT																														

SPECIFICATIONS

Insulator Material: Black LCP
Contact Material: BeCu
Plating: Au over 50 μ" (1.27 μm) Ni
Wire: 24, 26, 28 or 30 AWG
Operating Temp Range: -10 °C to +105 °C (PVC) -40 °C to +125 °C (*Teflon™ Fluoropolymer)
Current Rating (S2SD-24/T2M): 3.8 A per pin (2 pins powered)
Voltage Rating: 250 VAC/354 VDC

Notes: Teflon™ Fluoropolymer cable is intended for crimp only. Contact Samtec for solderable cable applications.

For wiring option information refer to drawings on web.

View complete specifications at: samtec.com?S2SD, samtec.com?S2SDT, samtec.com?S2SS & samtec.com?S2SST

ISD2	POSITIONS PER ROW	ROW OPTION	LATCH OPTION	SERIES	WIRE GAUGE	01	PLATING OPTION
	-05, -07, -10, -15, -20 (Standard sizes)	-S = Single Row	-M = Metal Retention Latch	CC81L = Contact, Loose	-2426 = 24 to 26 AWG		-L = 10 μm (0.25 μm) Gold on contact
	-25, -30 (Available with -D option only)	-D = Double Row	-S = Screw Down	CC81R = Contact, Full Reel (17,000 Parts per Reel)	-2830 = 28 to 30 AWG		

TOOLING

Hand Tool: CAT-HT-281-2430-13	Mini Applicator: CAT-MC-281-2426-XX-01 (24-26 AWG)
Extraction Tool: CAT-EX-169-01	Mini Applicator: CAT-MC-281-2830-XX-01 (28-30 AWG)

Note: Some lengths, styles and options are non-standard, non-returnable.

View complete specifications at: samtec.com?ISD2, samtec.com?CC81R & samtec.com?CC81L



(0.80 mm) .0315" PITCH • WIRE TO BOARD ASSEMBLY/COMPONENTS

SESDT	POSITIONS PER ROW	32	PLATING OPTION	ASSEMBLED LENGTH	OPTIONS
-------	-------------------	----	----------------	------------------	---------

= Double Row
Blue *Teflon™
Fluoropolymer Cable
(32 AWG)

-05, -10, -15, -20
(Standard sizes)

-G
= 10 μ" (0.25 μm)
Gold on contact area,
3 μ" (0.08 μm) Gold on tail

-"XX.X"
= Assembled
Length in Inches
(76.2 mm) 03.0" min.

Double Ended Assemblies

-L1
= Pin 1 to Pin 1

-L2
= Pin 1 to Pin 2

-L3
= Pin 1 to Pin N-1

-L4
= Pin 1 to Pin N

Single Ended Assembly

-L
= Latching

SESDT
Board Mates:
TEM-L1

SPECIFICATIONS

Insulator Material:
Natural Nylon
Contact Material:
BeCu
Plating:
Au over 50 μ" (1.27 μm) Ni
Wire:
Tinned Copper
Wire Insulation:
FEP
Operating Temp Range:
-55 °C to +125 °C
Current Rating:
1.9 A per pin
(2 pins powered)
Voltage Rating:
200 VAC/283 VDC

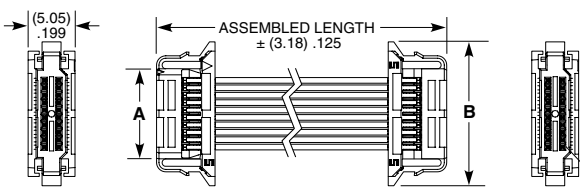

DOUBLE ENDED

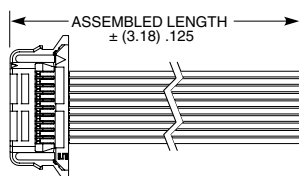

SINGLE ENDED

NO. OF POSITIONS	A	B
-05	(5.70) .224	(11.50) .453
-10	(9.70) .382	(15.50) .610
-15	(13.70) .539	(19.50) .768
-20	(17.70) .697	(23.50) .925

*Teflon™ is a trademark of The Chemours Company FC, LLC used under license by Samtec.

Note:
Teflon™ Fluoropolymer cable is intended for crimp only. Contact Samtec for solderable cable applications.

View complete specifications at: samtec.com?SESDT

ISDE	POSITIONS PER ROW	D	L	SERIES	WIRE GAUGE	PLATING	REEL OPTIONS
------	-------------------	---	---	--------	------------	---------	--------------

-05, -10, -15, -20
(Standard sizes)

-D
= Dual Row

-L
= Latch

CC396
= Contact

-3234
= 32 to 34 AWG

-G
= 10 μ" (0.25 μm)
Gold on contact area,
3 μ" (0.08 μm)
Gold on tail

-U
= Micro Reel
(4K Contacts)

-M
= Mini Reel
(15K Contacts)

-R
= Reel
(50K Contacts)

POSITIONS PER ROW	A	B
-05	(9.50) .374	(11.50) .453
-10	(13.50) .531	(15.50) .610
-15	(17.50) .689	(19.50) .768
-20	(21.50) .846	(23.50) .925

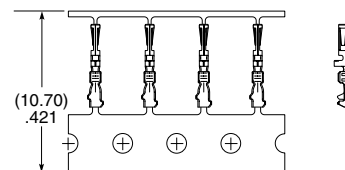
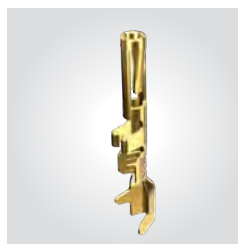
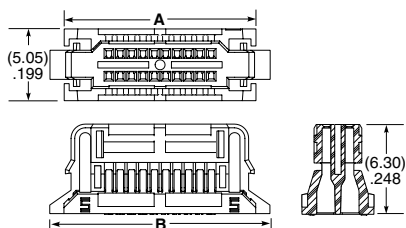
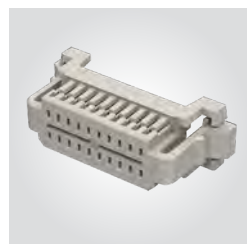

TOOLING

Hand Tool: CAT-HT-396-3232-12

Mini Applicator: CAT-MC-396-3232-XX-03

Note:
Some lengths, styles and options are non-standard, non-returnable

View complete specifications at: samtec.com?ISDE & samtec.com?CC396

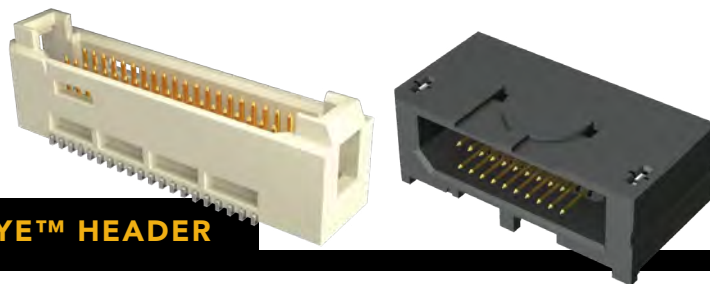

(0.80 mm) .0315" PITCH • MICRO TIGER EYE™ HEADER

TEM	1	NO. OF POSITIONS	02	DH1	PLATING OPTION	D	OPTION
		10, 15, 20, 25, 30, 35, 40, 45, 50 (Per Row) (Standard sizes)			-F = Gold Flash on contact, Matte Tin on tail		-A = Alignment Pin
					-L = 10 μ" (0.25 μm) Gold on contact, Matte Tin on tail		

TEM-DH
Board Mates:
SEM, SEML

SPECIFICATIONS

Insulator Material:
Black Liquid Crystal Polymer
Terminal Material:
Phosphor Bronze
Plating:
Au or Sn over
50 μ" (1.27 μm) Ni
Current Rating:
2.9 A per pin
(2 pins powered)
Voltage Rating:
235 VAC/332 VDC
Operating Temp Range:
-55 °C to +125 °C

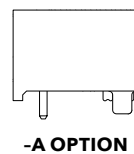
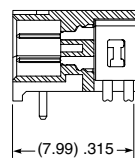
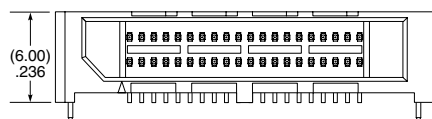
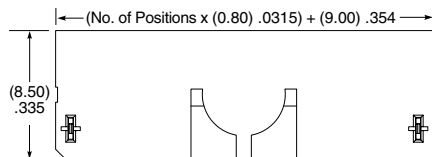

PROCESSING

Lead-Free Solderable:
Yes
SMT Lead Coplanarity:
(0.10 mm) .004" max.

View complete specifications at: samtec.com?TEM

TEM	1	POSITIONS PER ROW	02	03.0	PLATING OPTION	D	L1	OPTIONS
		05, 10, 15, 20 (Standard sizes)			-G = 10 μ" (0.25 μm) Gold on contact, Gold Flash on tail		-L1 = Latching	-K = (5.50 mm) .217" DIA. Polyimide film Pick & Place Pad
								-TR = Tape & Reel
								-FR = Full Reel Tape & Reel (must order max. quantity per reel; contact Samtec for quantity breaks)

TEM-L1
Cable Mates:
SESDT

SPECIFICATIONS

Insulator Material:
Natural Liquid Crystal Polymer
Terminal Material:
Phosphor Bronze
Plating:
Au over 50 μ" (1.27 μm) Ni
Current Rating:
1.9 A per pin (2 pins powered)
Voltage Rating:
200 VAC/283 VDC
Operating Temp Range:
-55 °C to +125 °C

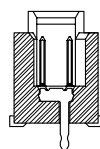
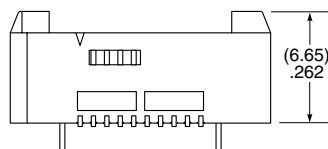
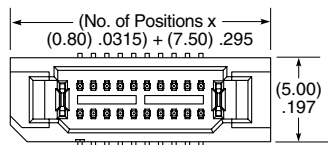

PROCESSING

Lead-Free Solderable:
Yes
SMT Lead Coplanarity:
(0.10 mm) .004" max.

Note:
Some lengths, styles and
options are non-standard,
non-returnable

View complete specifications at: samtec.com?TEM



(4.19 mm) .165" PITCH • WIRE TO BOARD ASSEMBLY/COMPONENTS

SERIES	PINS PER ROW	WIRE GAUGE	K	ASSEMBLED LENGTH	END OPTION	LATCH OPTION
PMSD = Double Row PVC Cable	-02,	-16	-K = Keyed Polarization	-"XX.XX" = Wire length in inches (88.90 mm) 03.50" min.	-S = Single Ended	-LUS = Plastic Latch up, straight
PMSDT = Double Row Blue *Teflon™ Fluoropolymer Cable (24 AWG only)	-03, -04,	-18			-D = Double Ended (Latch Required)	-LDS = Plastic Latch down, straight
PMSS = Single Row PVC Cable	-05, -08,	-206 (20 AWG/600 volts)				-LUX* = Plastic Latch up, crossed
PMSST = Single Row Blue *Teflon™ Fluoropolymer Cable (24 AWG)	-10, -15* (Standard sizes) *Only available for double row	-22				-LDX* = Plastic Latch down, crossed
		-24				*(PMSD/PMSDT only)

PMSD, PMSDT, PMSS, PMSST
Board Mates:
IPBT

SPECIFICATIONS

Insulator Material: Valox 457
Contact Material: Phosphor Bronze
Plating: Sn over 50 μm (1.27 μm) Ni
Operating Temp Range: -10 °C to +105 °C (PVC)
 -40 °C to +105 °C (Teflon™ Fluoropolymer)

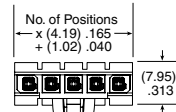

PMSD/PMSDT

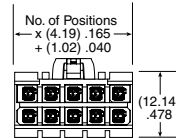

PMSS/PMSSST

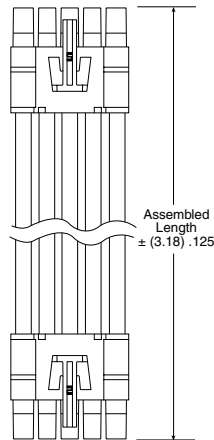

PMSD/IPBT		
WIRE GAUGE	CURRENT RATING (PER PIN)	VOLTAGE RATING
16 AWG	*10.4 A	300 VAC/424 VDC (PVC)
18 AWG	*8.8 A	
22 AWG	*5.7 A	
24 AWG	*5.2 A	

*2 PINS POWERED

*Teflon™ is a trademark of The Chemours Company FC, LLC used under license by Samtec.

Notes: Teflon™ Fluoropolymer cable is intended for crimp only. Contact Samtec for solderable cable applications.

For wiring option information refer to drawing on web.

View complete specifications at: samtec.com?PMSD, samtec.com?PMSDT, samtec.com?PMSS & samtec.com?PMSST

IPBD	POSITIONS PER ROW	ROW OPTION	K	SERIES	WIRE GAUGE	01	T	SP
	-02, -03, -04, -05, -08, -10, -15 (Standard sizes)	-S = Single Row -D = Double Row	-K = Keyed Polarization	CC69L = Contact, Loose CC69R = Contact, Full Reel (4,000 Parts per Reel)	-2024 = 20 to 24 AWG -1620 = 16 to 20 AWG		-T = Tin	

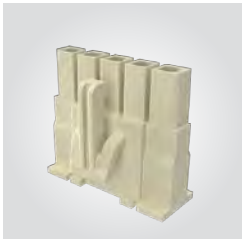

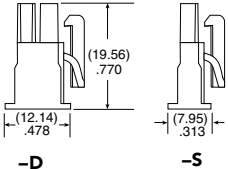

-D **-S**



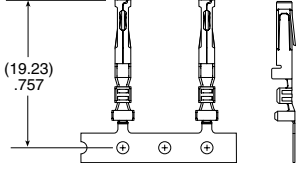

TOOLING

Hand Tool: CAT-HT-169-1620-13 (16-20 AWG)
 Hand Tool: CAT-HT-169-2024-13 (20-24 AWG)

Mini Applicator: CAT-MC-169-1620-XX-02 (16-20 AWG)
 Mini Applicator: CAT-MC-169-2024-XX-01 (20-24 AWG)
 Extraction Tool: CAT-EX-169-01

Note: Some lengths, styles and options are non-standard, non-returnable.

View complete specifications at: samtec.com?IPBD, samtec.com?CC69L & samtec.com?CC69R



(2.54 mm) .100" PITCH • WIRE TO BOARD ASSEMBLY/COMPONENTS

SERIES	PINS PER ROW	WIRE GAUGE	PLATING OPTION	ASSEMBLY LENGTH	END OPTION	K	LATCH OPTION
MMSD = Double Row PVC Cable	-02, -03, -04, -05,	-20	-F = Gold flash on contact, Tin on tail	-"XX.XX" = Assembly Length in Inches (82.55 mm) 03.25" min.	-S = Single Ended	-K = Keyed Polarization	(Metal latches for more rugged environments; -02, -05 & -10 positions only)
MMSDT = Double Row Blue *Teflon™ Fluoropolymer Cable (20, 24, 28, 30 AWG only)	-06, -08, -10, -12, -15, -16,	-20C = Color Coded Cable (MMSD & MMS only)	-L = 10 μm (0.25 μm) Gold on contact, Tin on tail		-D = Double Ended (Latch Required)		-M = Single Ended, Metal Latches (Leave blank for plastic)
MMSS = Single Row PVC Cable	-20, -25 (Standard sizes)	-22, -24					Double Ended (-D) Crossed requires MMSD/MMSDT
MMSST = Single Row Blue *Teflon™ Fluoropolymer Cable (20, 24, 28, 30 AWG)		-24C = Color Coded Cable (MMSD & MMS only)					-LUS = Plastic Latch up, straight
MMSD, MMSDT, MMSS, MMSST Board Mates: IPL1 (Does not mate with IPT1) Cable Mates: MMTD(T), MMTS(T)		-26, -28					-LDS = Plastic Latch down, straight
		-28C = Color Coded Cable (MMSD & MMS only)					-LUX = Plastic Latch up, crossed
		-30					-LDX = Plastic Latch down, crossed
							-MUS = Metal Latch up, straight
							-MDS = Metal Latch down, straight
							-MUX = Metal Latch up, crossed
							-MDX = Metal Latch down, crossed

-20C, -24C, -28C CABLE COLOR CODING	
PIN	COLOR
1	BROWN
2	RED
3	ORANGE
4	YELLOW
5	GREEN
6	BLUE
7	VIOLET
8	GRAY
9	WHITE
10	BLACK
ETC	REPEAT

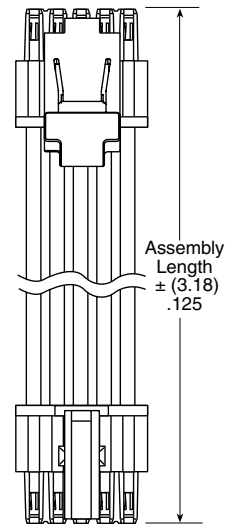
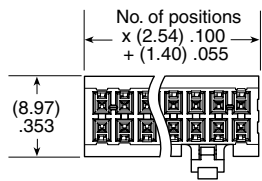

*Teflon™ is a trademark of The Chemours Company FC, LLC used under license by Samtec.
Teflon™ Fluoropolymer cable is intended for crimp only. Contact Samtec for solderable cable applications.

SPECIFICATIONS
Insulator Material: Nylon 66
Contact Material: Phosphor Bronze
Plating: Au or Sn over 50 μm (1.27 μm) Ni
Operating Temp Range: -10 °C to +80 °C (PVC) -40 °C to +125 °C (*Teflon™)
Current Rating: 4.8 A (2 pins powered)
Voltage Rating: 275 VAC/389 VDC

View complete specifications at: samtec.com?MMSD, samtec.com?MMSDT, samtec.com?MMSS & samtec.com?MMSST

IPD1	POSITIONS PER ROW	ROW OPTION	K	LATCH OPTION	SERIES	WIRE GAUGE	01	PLATING OPTION
	-02, -03, -04, -05, -06, -08, -10, -12, -15, -16, -20, -25 (Standard sizes)	-S = Single Row -D = Double Row	-K = Keyed Polarization	-M = Metal Latch (Metal for more rugged environments) (-02, -05 & -10 positions only) (Leave blank for plastic latch)	CC79L = Contact, Loose CC79R = Contact, Full Reel (12,000 Parts per Reel)	-2630 = 26 to 30 AWG -2024 = 20 to 24 AWG		-F = Gold flash on contact, Tin on tail -L = 10 μm (0.25 μm) Gold on contact, Tin on tail

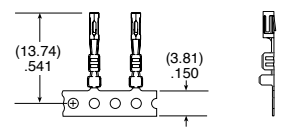
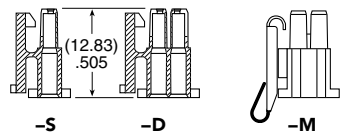
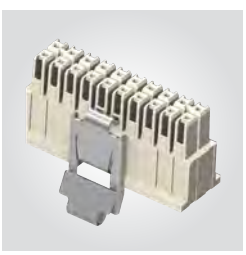

TOOLING

Note: Some lengths, styles and options are non-standard, non-returnable.

Hand Tool: CAT-HT-179-2030-13 (20-30 AWG)
Mini Applicator: CAT-MC-179-2024-XX-01 (20-24 AWG)
Mini Applicator: CAT-MC-179-2630 XX-01 (26-30 AWG)
Extraction Tool: CAT-EX-179-01

View complete specifications at: samtec.com?IPD1, samtec.com?CC79L & samtec.com?CC79R

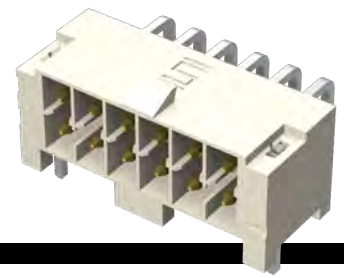

IPL1	1	PINS PER ROW	LEAD STYLE	PLATING OPTION	ROW OPTION	TAIL OPTION	K	OPTION
		02, 03, 04, 05, 06, 08, 10, 12, 15, 16, 20, 25 (Standard sizes)	-01 = Through-hole -02 = Surface Mount	-F = Gold flash on contact, Matte Tin on tail -L = 10 μ" (0.25 μm) Gold on contact, Matte Tin on tail	-S = Single Row -SH = Single Row Horizontal (-02 lead style only) -D = Double Row	-RA = Right-angle (-01 lead style only) -RE1 = Right-angle Elevated (-01 lead style only) (-K is a required callout)	-K = Keyed Polarization	-TR = Tape & Reel (-02 lead style only) Comes with Polyimide Pick & Place Pad -FR = Full Reel Tape & Reel (must order max. quantity per reel; contact Samtec for quantity breaks) (-02 lead style only) Comes with Polyimide Pick & Place Pad

IPL1

Cable Mates:
MMSD, MMSS,
MMSDT, MMSST

SPECIFICATIONS

Insulator Material:
Natural LCP
Terminal Material:
Phosphor Bronze
Plating:
Sn or Au over
50 μ" (1.27 μm) Ni
Operating Temp Range:
-55 °C to +125 °C
Current Rating:
4.8 A per pin
(2 pins powered)
Voltage Rating:
275 VAC/389 VDC

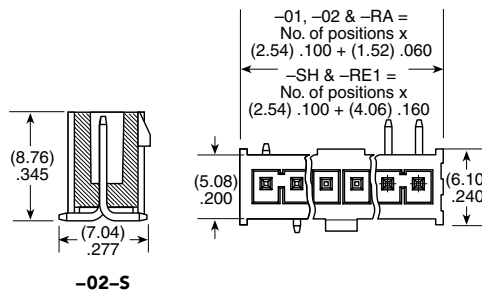

MMSD/IPL1	
WIRE GAUGE	CURRENT RATING (PER PIN)
20	4.8 A
22	4.3 A
24	3.9 A
26	3.5 A
28	2.6 A
30	2.1 A

2 PINS POWERED

PROCESSING

Lead-Free Solderable:
Yes
-S & -D (-02 Lead Style)
SMT Lead Coplanarity:
(0.10 mm) .004" max (02-05)
(0.13 mm) .005" max (06-10)*
(0.15 mm) .006" max (11-25)*
*(.004" stencil solution may be available; contact IPG@samtec.com)
-SH SMT Lead Coplanarity:
(0.15 mm) .006" max (02-25)*
*(.004" stencil solution may be available; contact ipg@samtec.com)

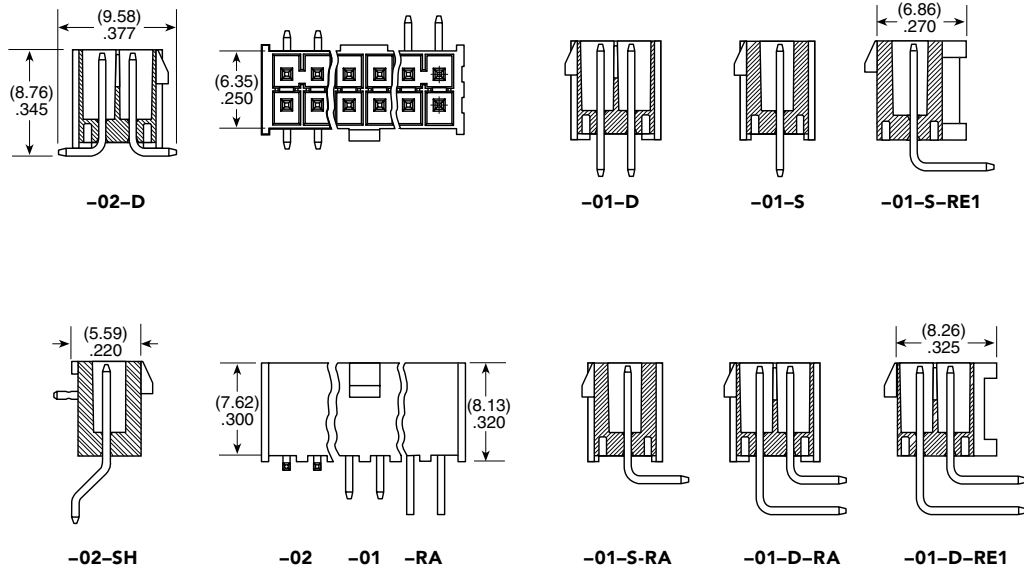

ALSO AVAILABLE

Contact Samtec

Other sizes
With or without plug polarization
Guide post holes
Other platings
Weld tab

Note:
Some lengths, styles and options are non-standard, non-returnable.

View complete specifications at: samtec.com?IPL1



(5.00 mm) .1969" PITCH • WIRE TO BOARD ASSEMBLY/COMPONENTS

MPSS	NO. OF POSITIONS	WIRE GAUGE	PLATING OPTION	ASSEMBLED LENGTH	END 1 OPTION	END 2 OPTION
------	------------------	------------	----------------	------------------	--------------	--------------

-02, -03,
-04, -06, -08

-14
-16

-L
= 10 μ" (0.25 μm)
Gold on contact

-T
= Matte Tin

"XX.XX"
= Wire length in
inches (83.00 mm)
03.25" min.

-SR
= Single End

-DR
= Double End

(Available with -DR only)

-NUS
= Notch up, straight

-NDS
= Notch down, straight

MPSS

Board Mates:

MPT

SPECIFICATIONS

Insulator Material:

Nylon 6/6

Contact Material:

Copper Alloy

Plating:

Au or Sn over

50 μ" (1.27 μm) Ni

Latch:

Nylon 6/6

Operating Temp Range:

-30 °C to +105 °C

Voltage Rating:

350 VAC/495 VDC

Wire:

14 or 16 AWG

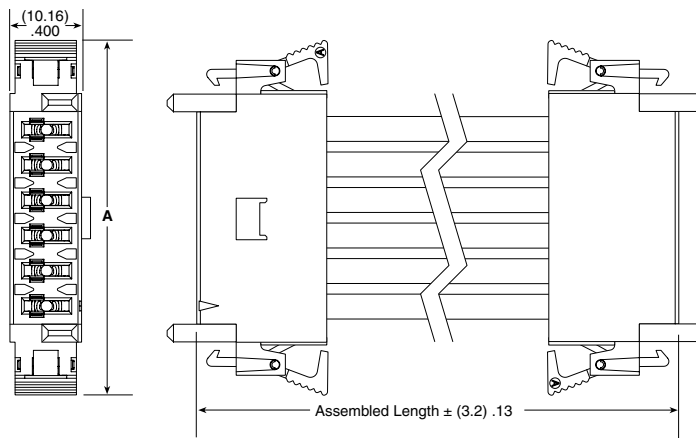

NO. OF POSITIONS	A
-02	(30.07) 1.184
-03	(35.07) 1.381
-04	(40.08) 1.578
-06	(50.09) 1.972
-08	(60.10) 2.366

MPSS/MPT-V	
WIRE GAUGE	CURRENT RATING (PER PIN)
14 AWG	19.7 A
16 AWG	15.9 A
1 PIN POWERED	

View complete specifications at: samtec.com?MPSS

IMS5	POSITIONS PER ROW	02	SERIES	WIRE GAUGE	01	PLATING OPTION
------	-------------------	----	--------	------------	----	----------------

-02, -03, -04, -06, -08

CC46L
= Contact, Loose

-1416
= 14 to 16 AWG

-L
= 10 μ" (0.25 μm)
Gold on contact

CC46R
= Contact, Full Reel

-T
= Matte Tin

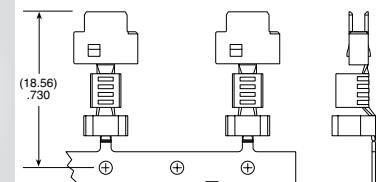
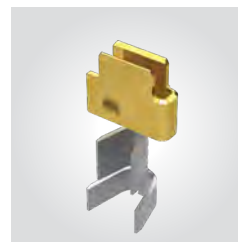
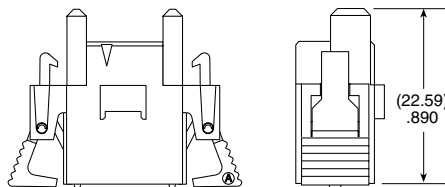
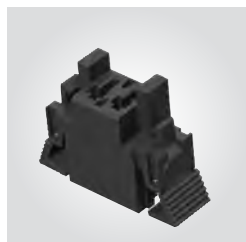

TOOLING

Hand Tool: CAT-HT-246-1416-14 (14-16 AWG)

Mini Applicator: CAT-MC-246-1416-XX-02 (14-16 AWG)

Extraction Tool: CAT-EX-MPSS-01

Note:

Some lengths, styles and options are non-standard, non-returnable

View complete specifications at: samtec.com?IMS5, samtec.com?CC46L & samtec.com?CC46R



30 SIGNAL/POWER COMBO WIRE TO BOARD ASSEMBLY/COMPONENTS

MPCC	2	SIGNAL PINS	2	PLATING OPTION	LEAD STYLE	LENGTH	END 1 OPTION	END 2 OPTION
		-16 = Total Signal Pins		-L = 10 μ" (0.25 μm) Gold on contact, Tin on tail (Power & Signal)	Specify LEAD STYLE from chart	-"XX.XX" = Assembled Length in Inches (101.60 mm) 04.00" min.	-S = Single End	(Available with -D only)
		-24 = Total Signal Pins		-T = Tin on contact and tail (Power), Gold on contact, Tin on tail (Signal)			-D = Double End	-NUS = Notch up, straight (Pin A1 to Pin AX)

MPCC
Board Mates:
MPTC

SPECIFICATIONS

Insulator Material:
Black LCP
Contact Material:
Signal: BeCu
Power: Copper Alloy
Plating:
Sn or Au over 50 μ" (1.27 μm) Ni
Current Rating:
Signal Pin (24 AWG):
3.4 A per pin
(4 adjacent pins powered)
Power Pin (14 AWG):
23.2 A per pin
(1 pin powered)
Operating Temp Range:
-10 °C to +105 °C
Voltage Rating:
250 VAC/354 VDC

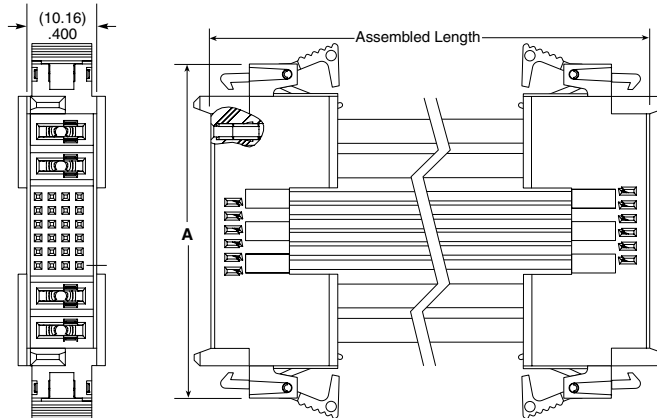

SIGNAL PINS	A
16	(44.55) 1.754
24	(48.55) 1.911

LEAD STYLE	PWR/SIG	AWG
-44	PWR	14
	SIG	24
-46	PWR	14
	SIG	26
-48	PWR	14
	SIG	28
-40	PWR	14
	SIG	30
-64	PWR	16
	SIG	24
-66	PWR	16
	SIG	26
-68	PWR	16
	SIG	28
-60	PWR	16
	SIG	30

View complete specifications at: samtec.com?MPCC

IMSC5	POWER PINS	SIGNAL PINS	POWER PINS	L	SERIES	WIRE GAUGE	01	PLATING OPTION
	-02 = Power Pins Per End	-16 = Total Signal Pins	-02 = Power Pins Per End	-L = Latch	CC81L = Contact, Loose	-2426 = 24 to 26 AWG		-L = 10 μ" (0.25 μm) Gold on contact
		-24 = Total Signal Pins			CC81R = Contact, Full Reel (17,000 Parts per Reel)	-2830 = 28 to 30 AWG		

SIGNAL PINS	A
-16	(44.55) 1.754
-24	(48.55) 1.911

Note: Power contact (CC46 Series) information on page 262.

TOOLING

Hand Tool: CAT-HT-281-2430-13 (Signal: 24-30 AWG)
CAT-HT-246-1416-13 (Power: 14-16 AWG)

Extraction Tool: CAT-EX-169-01 (Signal)
CAT-EX-MPSS-01 (Power)

Mini Applicator: CAT-MC-246-1416-XX-01 (Power 14-16 AWG)
CAT-MC-281-2426-XX-01 (Signal: 24-26 AWG)
CAT-MC-281-2830-XX-01 (Signal: 28-30 AWG)

Note: Some lengths, styles and options are non-standard, non-returnable

View complete specifications at: samtec.com?IMSC5, samtec.com?CC81R & samtec.com?CC81L

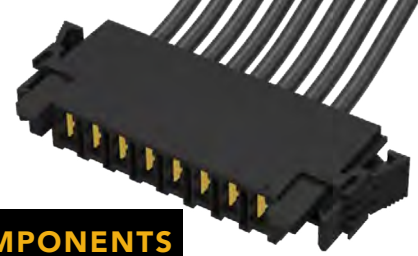

(6.35 mm) .250" PITCH • WIRE TO BOARD ASSEMBLY/COMPONENTS

PESS	NO. OF POSITIONS	WIRE GAUGE	PLATING OPTION	ASSEMBLED LENGTH	END 1 OPTION	END 2 OPTION
	-02, -04, -06, -08	-10 -12	-L = 10 μ" (0.25 μm) Gold on contact, Matte Tin on tail -T = Matte Tin on tail	-"XX.XX" = Wire length in inches (152.4 mm) 06.00" min.	-SR = Single End -DR = Double End	(Available with -DR only) -NUS = Notch up, straight (Available with -DR only) -NDS = Notch down, straight

PESS
Board Mates:
PET

SPECIFICATIONS

Insulator Material:
Nylon Black
Contact Material:
Copper Alloy
Plating:
Sn or Au over
50 μ" (1.27 μm) Ni
Operating Temp Range:
-30 °C to +105 °C
Voltage Rating:
450 VAC/636 VDC
Wire:
10 or 12 AWG

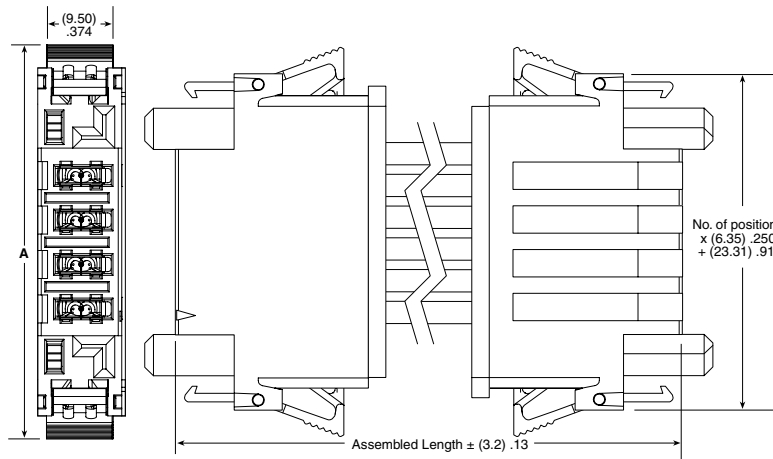

NO. OF POSITIONS	A
-02	(43.9) 1.73
-04	(56.6) 2.23
-06	(69.3) 2.73
-08	(82.0) 3.23

PESS/PET	
WIRE GAUGE	CURRENT RATING (PER PIN)
10 AWG	34.5 A
12 AWG	29.7 A

1 PIN POWERED

View complete specifications at: samtec.com?PESS

IPS6	POSITIONS PER ROW	01	LATCH	SERIES	WIRE GAUGE	PLATING OPTION
	-02, -04, -06, -08		-L = Latch	CC10R = Contact, Full Reel CC10L = Contact, Loose	-1012 = 10 to 12 AWG	-L = 10 μ" (0.25 μm) Gold on contact, Matte Tin on tail -T = Matte Tin on tail

TOOLING

Hand Tool: CAT-HT-310-1012-14
Mini Applicator: CAT-MC-310-1012-XX-02

Note:
Some lengths, styles and options are non-standard, non-returnable

View complete specifications at: samtec.com?IPS6, samtec.com?CC10L & samtec.com?CC10R

FLEXIBLE STACKING

VARIETY OF PITCHES, CONTACT SYSTEMS & ORIENTATIONS • HIGHLY CUSTOMIZABLE

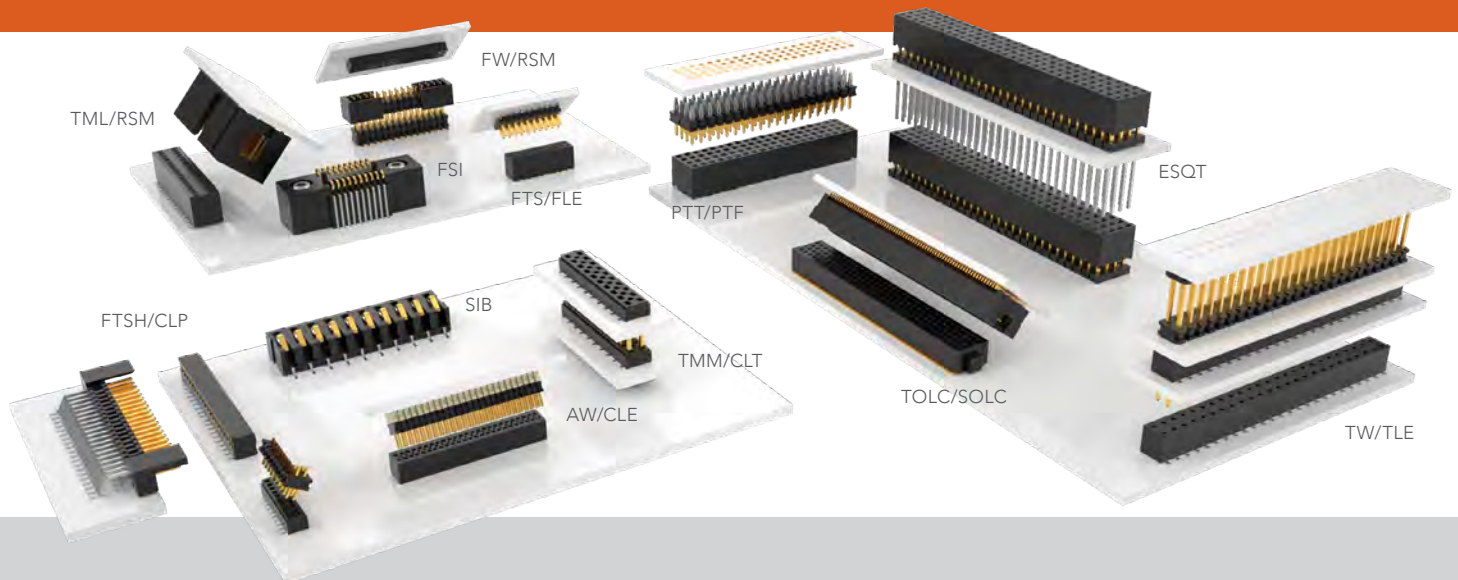

270-271

ONE-PIECE INTERFACES

1.00 mm (.0394") Pitch (FSI)	270
1.00" (2.54 mm) Pitch (SIB, SIR1)	271

272-277

MICRO BLADE & BEAM

0.50 mm (.0197") Pitch Low Profile Systems (LTH, LSH)	272
Floating Contact Systems (FT5, FS5)	273
Basic Blade & Beam Systems (BXH, BXS, BXE)	274-277

278-294

MICRO PIN & SOCKET

0.80 mm (.0315") Pitch Headers & Sockets (FTE, CLE, AW)	278-279
1.00 mm (.0394") Pitch Headers, Stackers & Sockets (FTMH, FTM, MW, CLM, MLE)	280-282
Quad Row Headers & Sockets (SOLC, TOLC)	283
.050" (1.27 mm) Pitch Headers, Stackers & Sockets (FTSH, FTS, FW, CLP, FLE)	284-289
.050" (1.27 mm) x 100" (2.54 mm) Pitch Headers, Stackers & Sockets (TMS, HTMS, TML, ZML, DWM, FTR, RSM, SLM, SMS)	290-294

295-328

BOARD-TO-BOARD

2.00 mm (.0787") Pitch Headers & Stackers (TMM, MMT, MTMM, TMMH, LTMM, ZLTMM, TMMS, TSH, TW)	295-302
2.00 mm (.0787") Pitch Press-Fit Headers & Sockets (PTT, PTF, PTHF, ESQT-368)	303-304
2.00 mm (.0787") Pitch Sockets (SQW, SQT, MMS, TLE, CLT)	305-307
2.00 mm (.0787") Pitch Self Mating Hermaphroditic Strips (LS2)	308
.100" (2.54) Pitch Square Post Headers & Stackers (PHT, PHF, TSW, HTSW, TSM, MTSW, HMTSW, TLW, MTLW, HW, DW, EW, ZW, TSS, HTSS, ZSS)	309-319
.100" (2.54 mm) Pitch Square Post Sockets (SSW, SSQ, SSM, ESW, ESQ, HLE, BCS, BSW, SLW, CES)	320-327
Shunts & Jumpers (SNT, MNT, 2SN, SNM, JL)	328

FLEXIBLE STACKING

With the largest variety of board-to-board interconnects, Samtec makes it easy to find board stackers for any application. Header and socket systems are available in a variety of pitch, density, stack height, orientation and many more standard or custom options.

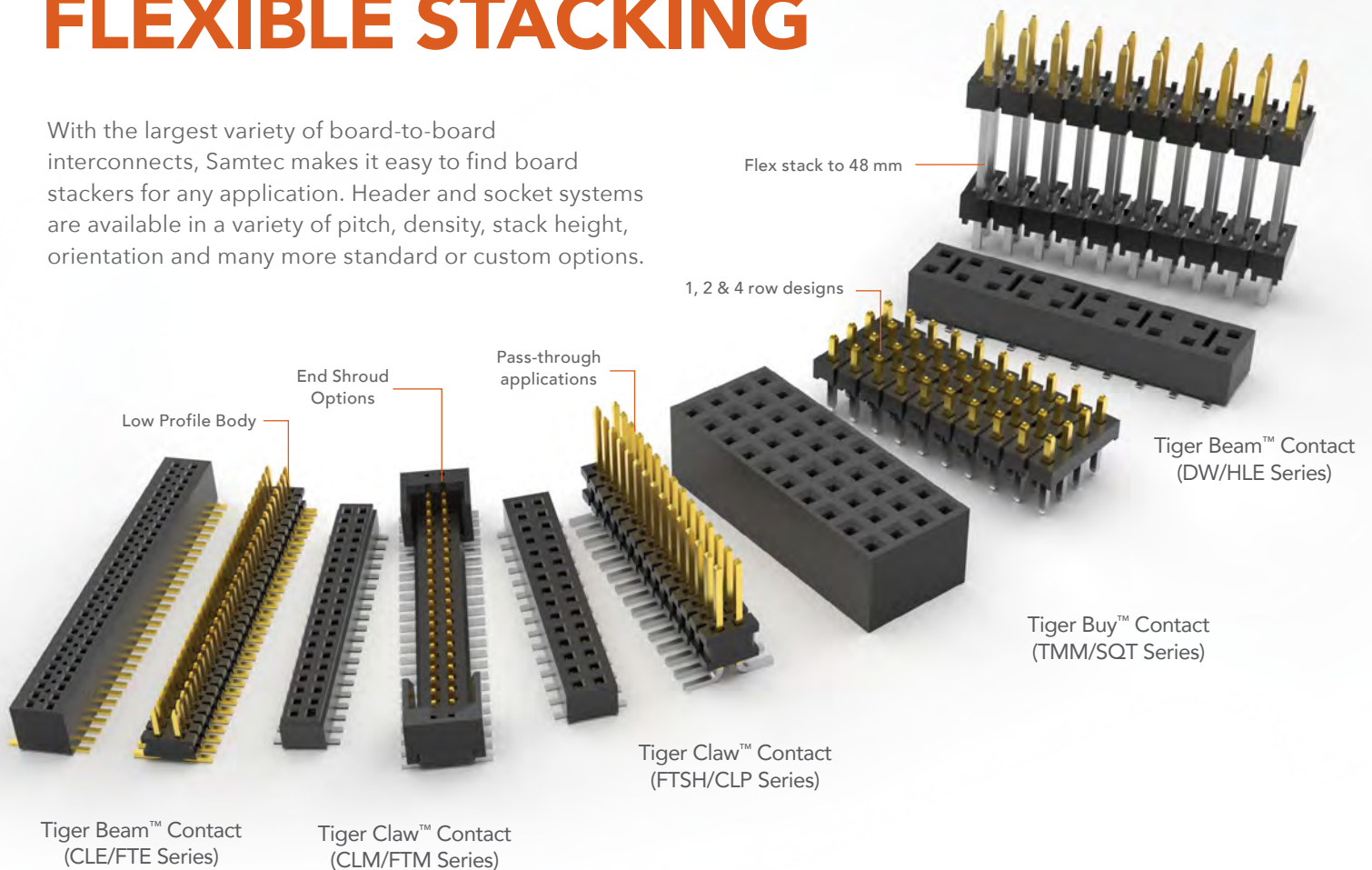

INCREDIBLE FLEXIBILITY

- Post height: Adjustable in .005" (0.13 mm) increments
- Body positions: Adjustable in .005" (0.13 mm) increments
- Board stacking distance: 1.65 mm (.065") – 48.51 mm (1.910")
- Number of pins: 2-300
- Number of rows: 1-6

CUSTOMIZABLE

- Mix-and-match headers and sockets to find the right solution
- Quick and easy custom parts are available. Contact asp@samtec.com

VARIETY OF PITCHES

- 0.80 mm (.0315")
- 1.00 mm (.0394")
- .050" (1.27 mm)
- .050" x .050" (1.27 x 1.27 mm)
- .050" x .100" (1.27 x 2.54 mm)
- 2.00 mm (.0787")
- .100" (2.54 mm)
- .156" (3.96 mm)
- .200" (5.08 mm)

BUILD IT YOURSELF

Check out Solutionator® to quickly build a mated set for your specific application. Visit samtec.com/solutionator

Solutionator **FLEX STACKING**
GET A MATED SET IN SECONDS®

VARIETY OF CONTACTS

TIGER EYE™ CONTACT

- High-reliability
- High mating cycles
- Multi-finger contact



TIGER CLAW™ CONTACT

- Pass-through
- Ultra-low profile
- Dual wipe contact

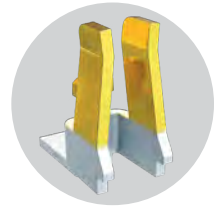

TIGER BUY™ CONTACT

- High-retention
- Cost-effective
- Tuning fork contact

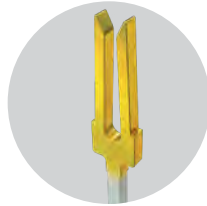

TIGER BEAM™ CONTACT

- Best cost
- Reliable performance
- Post & beam contact



VARIETY OF ORIENTATIONS/APPLICATIONS

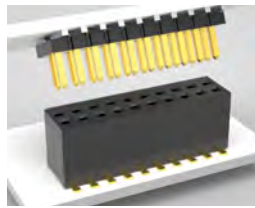

Standard

- Choice of contact system
- Single, double and triple row designs
- Largest variety

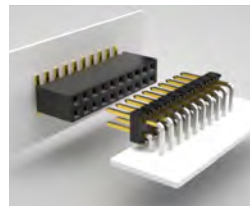

Right-Angle

- Design flexibility
- Tiger Claw™ & Tiger Buy™ contacts
- Through-hole, surface mount



Low Profile

- Down to 1.65 mm (.065") stack height
- Tiger Claw™ contacts
- Space saving

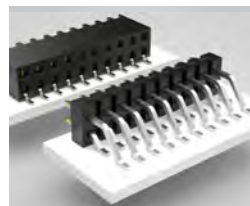

Coplanar

- 1-4 row designs
- Surface mount, through-hole or mixed technology
- Tiger Claw™ & Tiger Beam™ contacts



Elevated

- Up to 48.51 mm (1.910") stack height
- Design flexibility
- Clearance, air flow

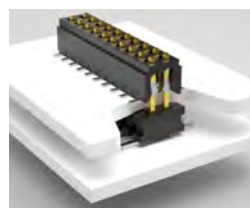

Bottom Entry

- Tiger Claw™ contacts
- Access to components when mated
- Space savings



Pass-Through

- Connect three or more boards
- Tiger Claw™ & Tiger Beam™ contact systems
- Surface mount or offset through-hole



Self-Nesting

- Tiger Buy™ contacts
- Press-fit or through-hole tails
- PC/104-Plus™ embedded applications

BOARD STACKING REFERENCE

Focused/most popular series in charts. For all flexible stacking solutions, visit samtec.com/connectors

ONE-PIECE, 0.80 mm (.0315") & 1.00 mm (.0394") PITCH

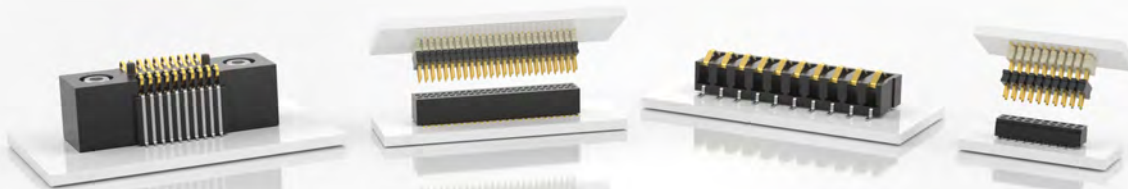

SERIES	FSI	SEI	SIB	CLE	FTE	CLM	FTMH/FTM	MLE	MW	
PITCH	1.00 mm (.0394")		.100" (2.54 mm)	0.80 mm (.0315")		1.00 mm (.0394")				
ORIENTATION	V				V & RA	V	V & RA	V		
BOARD STACKING (MM)	MIN	3	1.65	3.8	5	5	3.48		4.57	4.62
	MAX	10			9.14		8.43	5.11	9.27	
CONTACT SYSTEM					Tiger Beam™		Tiger Claw™		Tiger Beam™	
MATES	One-Piece				FTE, AW	CLE	FTM, FTMH, MW	CLM, MLE	FTM, FTMH, MW	CLM, MLE
PAGE	270	See Website	271	278	278	282	280	282	281	

.050" (1.27 mm) PITCH HEADERS & SOCKETS

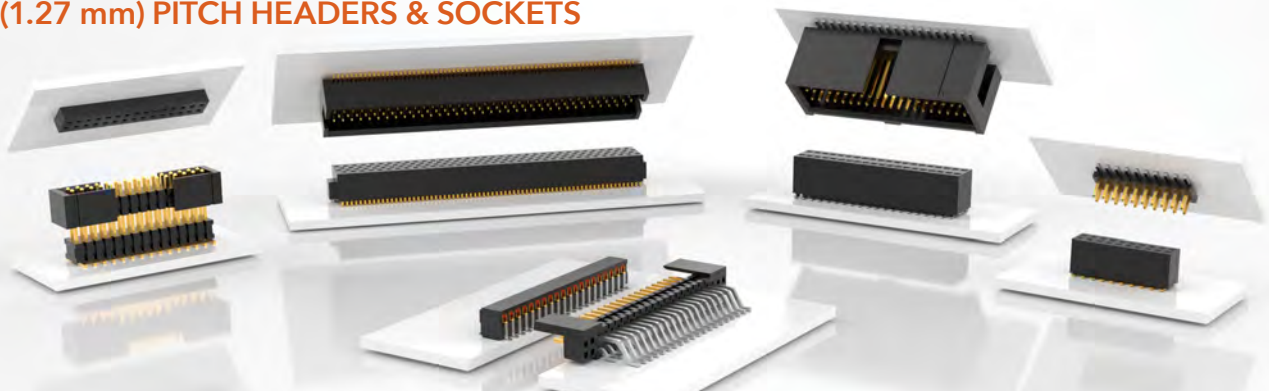

SERIES	CLP	FLE	FTS	FTSH	FW	SOLC	TOLC	DWM/HDWM	FTR	RSM	SLM	
PITCH	.050" x .050" (1.27 mm x 1.27 mm)							.050" x .100" (1.27 mm x 2.54 mm)				
ORIENTATION	V & RA	V		V & RA	V							
BOARD STACKING (MM)	MIN	3.53	5.82	3.53	5.18	7.72	6.35	9.65	9.78		7.11	
	MAX	17.75	19.15	5.82	7.49	19.15	12.00	22.99	14.73	19.69	19.43	
CONTACT SYSTEM	Tiger Claw™	Tiger Beam™					Tiger Buy™					Tiger Buy™
MATES	FTSH, FTS, FW			CLP, FLE			TOLC	SOLC	SMS, SLM, RSM		FTR, HTMS, HDWM, DWM, TML, ZML, TMS	HTMS, TMS, MTMS, DWM, HDWM, FTR, HMTMS
PAGE	288	289	286	284-285	287	283	283	292	293	293	294	

2.00 mm (.0787") PITCH HEADERS & SOCKETS

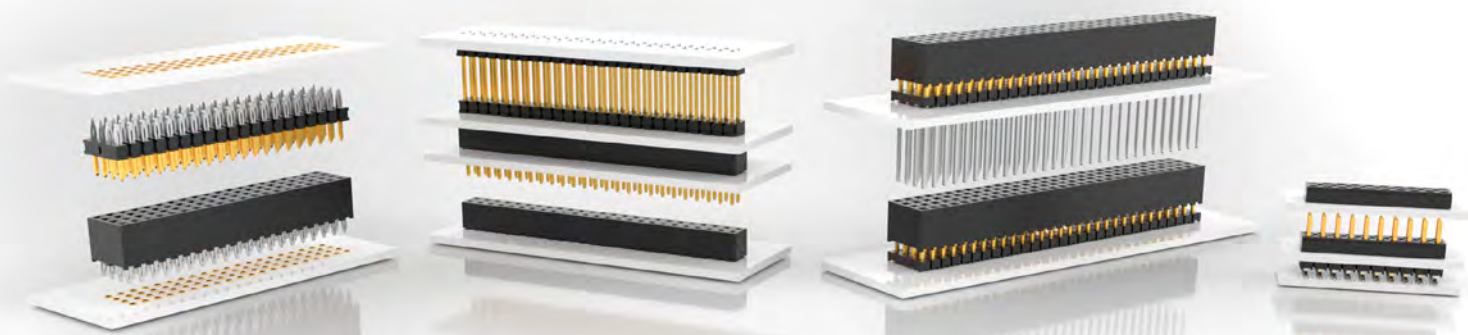

SERIES	MMT	TMM/MTMM	TMMH	TW	ZLTMM	CLT	ESQT/-368	MMS	SMM	SQT	SQW	TLE
ORIENTATION	RA	V & RA		V				V & RA	V	V & RA	V	
TERMINATION	SMT & MT	T/H & SMT			T/H	T/H & SMT	T/H	T/H & SMT	SMT	T/H	T/H & SMT	SMT
BOARD STACKING (MM)	MIN	2	3.63	4.14	7.49	7.62	3.63	9.37	5.94	6.07	7.85	6.99
	MAX	4	18.87	22.07	43.31	13.34	4.98	43.31	19.81	17.78	29.59	17.53
CONTACT SYSTEM						Tiger Claw™	Tiger Buy™	Tiger Claw™	Tiger Eye™	Tiger Buy™		Tiger Beam™
MATES	CLT, SQT, SQW, ESQT, TLE, SMM, MMS				SQT, SQW, ESQT, SMM	TMM, TMMH, MTMM, MMT, TW, TSH	TMMH, TMM, MMT, TW, LTMM, ZLTMM, ESQT, PTT, TSH, TMMS, PTHF	TMMH, TMM, MMT, TW, LTMM, ZLTMM, TSH	TMM, TMMH, MTMM, MMT, TW, PTT, ZLTMM	TMMH, TMM, MTMM, MMT, TW, LTMM, ZLTMM, PTT, ESQT, TSH	TMMH, TMM, MTMM, MMT, TW, TSH, LTMM, PTT	TMMH, TMM, MTMM, MMT, TW, LTMM, ZLTMM, TSH
PAGE	297	295-297	298-299	302	300	307	304	306	246	305	305	307

.100" (2.54 mm) PITCH HEADERS & SOCKETS



SERIES	DW, EW, ZW	HW	MTSW/HMTSW	TLW/MTLW	TSM	TSW/HTSW	BCS	ESW, ESQ	HLE	SSM	SSQ	SSW
ORIENTATION	V		V & RA				V & RA	V		V & RA		
TERMINATION	T/H	T/H & SMT	T/H		SMT & MT	T/H		T/H & SMT	SMT	T/H	T/H & SMT	
BOARD STACKING (MM)	MIN	13.59	10.03	7.24	6.1	7.47	7.87	9.02	13.59	7.47	11.18	10.03
	MAX	48.51	30.73	46.36	20.96	14.48	35.69	18.92	48.51	26.16	30.1	38.35
CONTACT SYSTEM							Tiger Claw™	Tiger Buy™	Tiger Beam™	Tiger Claw™	Tiger Buy™	
MATES	SSW, SSQ, ESW, ESQ, CES, SLW, BSW, BCS, SSM, HLE, PHF		SSW, SSQ, ESW, ESQ, BCS, BSW, CES, SLW, HLE, SSM	BSW, CES, SLW, HLE	SSW, SSQ, SSM, BSW, ESW, ESQ, BCS, SLW, CES, HLE	SSW, SSQ, SSM, ESW, ESQ, BCS, BSW, CES, SLW	TSW, MTSW, HTSW, HMTSW, TSS, ZSS, DW, EW, ZW, HW, TSM, MTLW, PHT	TSW, MTSW, EW, MTLW, TSS, ZSS, TSM, DW, ZW, HW, TSSH, HTSS	TSW, MTSW, DW, EW, ZW, TLW, TSM, MTLW, HW	TSW, MTSW, TST, TSS, ZST, ZSS, DW, EW, ZW, TSM, HMTSW, HTSW, TSSH, BST, HTSS, TLW, MTLW	TSW, MTSW, MTLW, EW, ZW, TSS, ZSS, TSM, TSSH, HTSS	TSW, MTSW, HMTSW, MTLW, EW, ZW, TSS, HTSS, ZSS, TSM, TSSH, DW, HW
PAGE	318	317	314-315	316	312-313	310-311	325	323	324	322	320-321	

LOW PROFILE AND ELEVATED ONE-PIECE

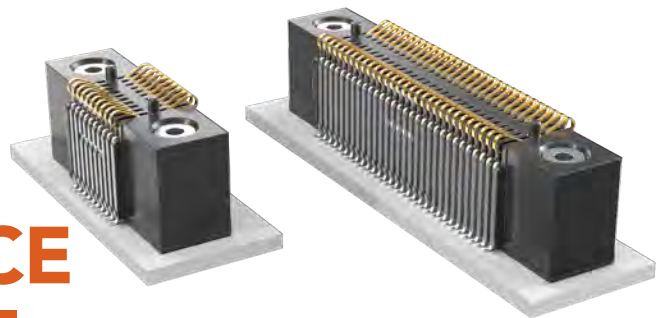

(1.00 mm) .0394" PITCH • FSI SERIES

SPECIFICATIONS

Insulator Material:
Liquid Crystal Polymer
Contact Material:
BeCu
Current Rating:
2.8 A per pin
(2 pins powered)
Voltage Rating:
220 VAC/311 VDC
Operating Temp Range:
-55 °C to +125 °C
Plating:
Au over 50 μ" (1.27 μm) Ni

PROCESSING

Lead-Free Solderable:
Yes
SMT Lead Coplanarity:
(0.10 mm) .004" max (05-30)
(0.15 mm) .006" max (50)*
*(.004" stencil solution may be available; contact ipg@samtec.com)
Compression Board:
Gold Pads required

OTHER SOLUTIONS

Low Profile

See www.samtec.com?SEI

.050" (1.27 mm) Pitch

See www.samtec.com?SIBF

FSI	1	PINS PER ROW	BODY HEIGHT	PLATING OPTION	ROW OPTION	INSERT OPTION	ALIGNMENT OPTION	OTHER OPTION
-----	---	--------------	-------------	----------------	------------	---------------	------------------	--------------

10, 20,
30, 50
(Insert/Screw
Option)

05,
10, 20,
30, 50
(Short
Version)

-03
= 3 mm
-06
= 6 mm
-10
= 10 mm

-L
= 10 μ"
(0.25 μm)
Gold on
contact,
Matte Tin
on tail
(Not
available
with
-03 body
height)

-G
= 10 μ"
(0.25 μm)
Gold
(-03 only)

-S
= Single
Row
(Available
with 5, 10
& 20 pins
with -AD
alignment
pin)

-D
= Double
Row

Leave blank for Short
Version
(No screw
down
inserts or
holes)

-E
= #2-56 x
1/16" screw
thread

-M
= 2.00 mm
x 0.40 mm
screw thread

Leave blank for no
Alignment Pin

-AD
= Alignment Pin
Top & Bottom

-WT
= Weld Tab
(Available
with -S row
option & -06
& -10 body
height only)

-K
= Polyimide
Film Pick &
Place Pad
(50 position
with threaded
insert option
only)

-P
= Plastic Pick
& Place Pad
(5.08 mm)
.200" x
(12.45 mm)
.490"
(50 not
available
with -E)
(Not available
with -S
row option
or -03 body
height)

-TR
= Tape &
Reel

-FR
= Full Reel
Tape & Reel
(must order
max. quantity
per reel;
contact
Samtec for
quantity
breaks)

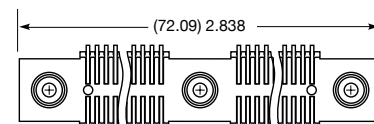
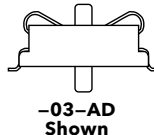
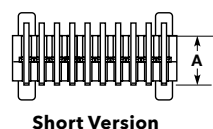
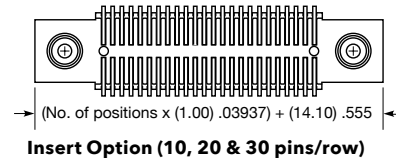
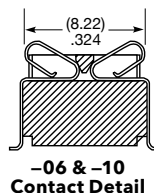
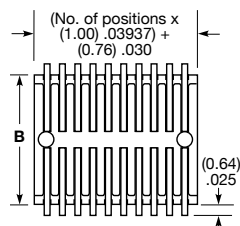

Double Row Version -03, -06, -10

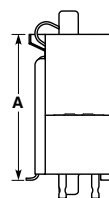
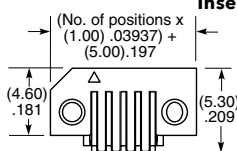
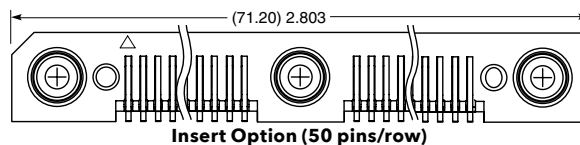

Short Version

-03-AD Shown

-WT Option
(-06 & -10 Body only)

Single Row Version -03, -06, -10

BODY HEIGHT	A	B
-03	(3.00) .118	(8.76) .345
-06	(6.00) .236	(9.02) .355
-10	(10.00) .394	(9.02) .355

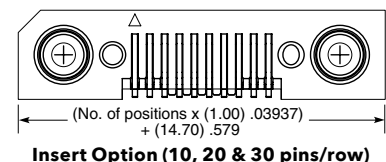

ALSO AVAILABLE

Contact Samtec

No alignment pin
Top side alignment pin
Bottom side alignment pin
Other platings

Notes:
Applications requiring 40-50
positions without threaded
inserts, please contact
Samtec Interconnect
Processing Group.

Some lengths, styles and
options are non-standard,
non-returnable.

ONE-PIECE INTERFACES

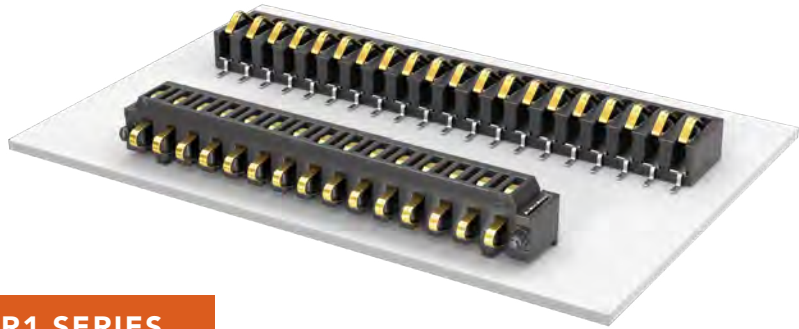

(2.54 mm) .100" PITCH • SIB/SIR1 SERIES

SPECIFICATIONS

Insulator Material:
Black Liquid Crystal Polymer
Contact Material:
Phosphor Bronze
Plating:
Au or Sn over
50 μ" (1.27 μm) Ni
Operating Temp Range:
-55 °C to +125 °C
Current Rating:
2.6 A per pin
(1 pin powered)
Voltage Rating:
280 VAC/396 VDC

PROCESSING

Lead-Free Solderable:
Yes
SMT Lead Coplanarity:
(0.10 mm) .004" max (02-19)
(0.15 mm) .005" max (20-30)*
*(.004" stencil solution
may be available; contact
ipg@samtec.com)

Notes:
The SIB Series
is intended for vertical
mating only.

Some lengths, styles and
options are non-standard,
non-returnable.



02 thru 30
(Per Row)

-F
= Gold flash
on contact,
Matte Tin on tail

-LC
= Locking
Clip
(Manual
placement
required)

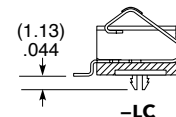
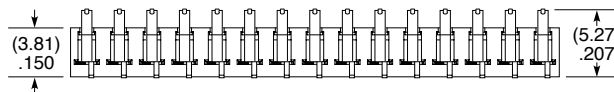

SPECIFICATIONS

Insulator Material:
Black LCP
Contact Material:
Phosphor Bronze
Weld Tab:
Phosphor Bronze
Plating:
Au or Sn over
50 μ" (1.27 μm) Ni
Current Rating:
2.8 A per pin
(1 pin powered)
Voltage Rating:
375 VAC/530 VDC

PROCESSING

Lead-Free Solderable:
Yes
SMT Lead Coplanarity:
(0.10 mm) .004" max

Note:
Some lengths, styles and
options are non-standard,
non-returnable.



-03, -05, -10, -15
(Per Row)

-L
= 10 μ" (0.25 μm)
Gold on contact,
Matte Tin on tail

-A
= Alignment Pin
-K
= (4.00 mm) .157"
DIA Polyimide
Film Pick &
Place Pad

-TR
= Tape & Reel

-FR
= Full Reel
Tape & Reel
(must order max.
quantity per reel;
contact Samtec for
quantity breaks)

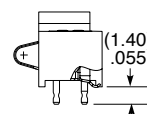
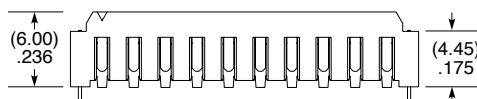
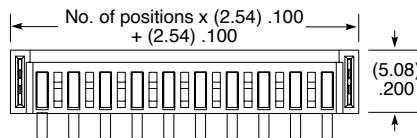

LOW PROFILE BLADE AND BEAM

(0.50 mm) .0197" PITCH • LTH/LSH SERIES



14
G b p s

LTH
Mates:
LSH

LSH
Mates:
LTH

LTH	-	NO. OF POSITIONS PER ROW	-	01	-	PLATING OPTION	-	D	-	A	-	OTHER OPTION
-----	---	--------------------------	---	----	---	----------------	---	---	---	---	---	--------------

-010, -020,
-030, -040, -050

-G
= 10 μm
(0.25 μm)
Gold

-K
= (5.50 mm)
.217" DIA
Polyimide
film Pick &
Place Pad

-TR
= Tape & Reel

-FR
= Full Reel
Tape & Reel
(must order max.
quantity per reel;
contact Samtec for
quantity breaks)

SPECIFICATIONS

Insulator Material:

Liquid Crystal
Polymer

Terminal Material:

Phosphor Bronze

Contact Material:

BeCu

Plating:

Au over 50 μm (1.27 μm) Ni

Current Rating:

2.6 A per pin
(2 pins powered)

Voltage Rating:

188 VAC/266 VDC

Operating Temp Range:

-55 °C to +125 °C

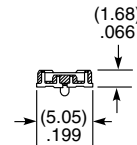
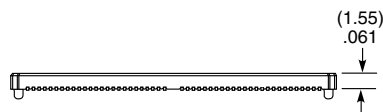
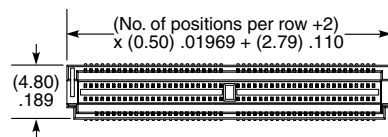

PROCESSING

Lead-Free Solderable:

Yes

SMT Lead Coplanarity:

(0.10 mm) .004" max

Board Stacking:

For applications requiring more than two connectors per board, contact ipg@samtec.com

LSH	-	NO. OF POSITIONS PER ROW	-	01	-	PLATING OPTION	-	D	-	A	-	OTHER OPTION
-----	---	--------------------------	---	----	---	----------------	---	---	---	---	---	--------------

-010, -020,
-030, -040, -050

-G
= 10 μm
(0.25 μm)
Gold

-K
= (7.50 mm)
.295" DIA
Polyimide
film Pick &
Place Pad

-TR
= Tape & Reel

-FR
= Full Reel
Tape & Reel
(must order max.
quantity per reel;
contact Samtec for
quantity breaks)

MATED HEIGHT

LEAD STYLE	MATED HEIGHT*
-01	(2.31 mm) .091"

*Processing conditions will affect mated height.

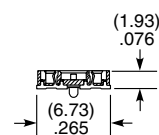
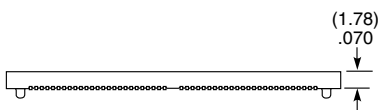
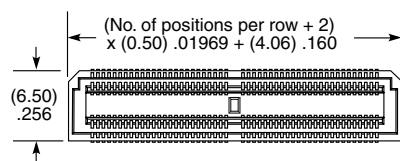

Note:

Some lengths, styles and options are non-standard, non-returnable.

HIGH-SPEED FLOATING CONTACT SYSTEM

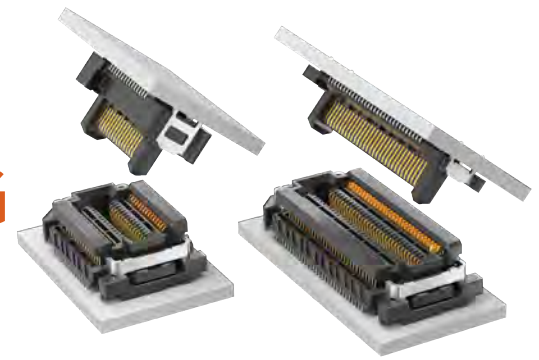

(0.50 mm) .0197" PITCH • FT5/FS5 SERIES

FT5
Mates:
FS5

FS5
Mates:
FT5

SPECIFICATIONS

Insulator Material:
Black Liquid Crystal Polymer
Contact Material:
Phosphor Bronze (FT5)
BeCu (FS5)
Weld Tab:
Phosphor Bronze
Plating:
Au or Sn over
50 μ " (1.27 μ m) Ni
Current Rating:
1.8 A per pin
(2 pins powered)
Voltage Rating:
180 VAC/255 VDC
Operating Temp Range:
-55 °C to +125 °C
Lead-Free Solderable:
Yes

FT5	NO. OF POSITIONS	LEAD STYLE	PLATING OPTION	ROW OPTION	TH	OPTION
-----	------------------	------------	----------------	------------	----	--------

-15, -30
(Per Row)

-01.0
= 1 mm
Body
Height

-L
= 10 μ "
(0.25 μ m)
Gold on
contact,
Matte Tin
on tail

-DV
= Vertical

Leave blank
for -RA

Required
callouts

-RA
= Right-
angle

-TH
= Through-hole
weld tab

-P
= Pick &
Place Pad
(-DV only)

-K
= (5.00 mm)
.197" DIA
Polyimide
Film Pick &
Place Pad
(-RA only)

-TR
= Tape &
Reel

-FR
= Full Reel
Tape & Reel
(must order
max. quantity
per reel;
contact
Samtec for
quantity
breaks)

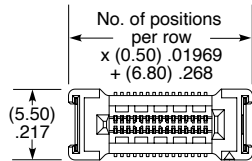

LEAD STYLE	A
-01.0	(3.72) .146
-03.0	(5.72) .225

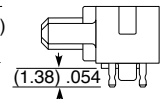
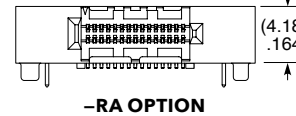
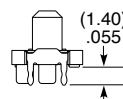
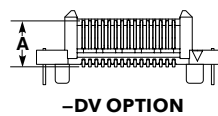
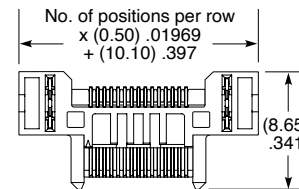

MATED HEIGHT *

FS5 LEAD STYLE	FT5 LEAD STYLE	
	-01.0	-03.0
-04.0	(5.00 mm) .197"	(7.00 mm) .276"

*Processing conditions will affect mated height.

FS5	NO. OF POSITIONS	LEAD STYLE	PLATING OPTION	DV	TH	K	XR
-----	------------------	------------	----------------	----	----	---	----

-15, -30
(Per Row)

-04.0
= 4 mm
Body
Height

-L
= 10 μ "
(0.25 μ m)
Gold on
contact,
Matte Tin
on tail

-TH
= Through-hole
weld tab

-K
= (8.25 mm)
.325" DIA
Polyimide
Film Pick &
Place Pad

-TR
= Tape & Reel

-FR
= Full Reel
Tape & Reel
(must order
max. quantity
per reel;
contact
Samtec for
quantity
breaks)

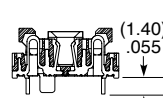
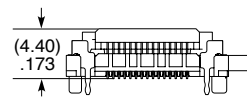
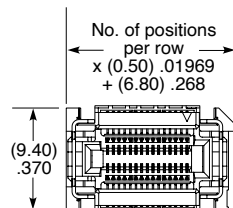

Notes:
Contact system provides float in X (0.50 mm) and Y (0.20 mm) directions.

Some lengths, styles and options are non-standard, non-returnable.

BASIC BLADE & BEAM HEADER

(0.50 mm) .0197" PITCH • BTH SERIES

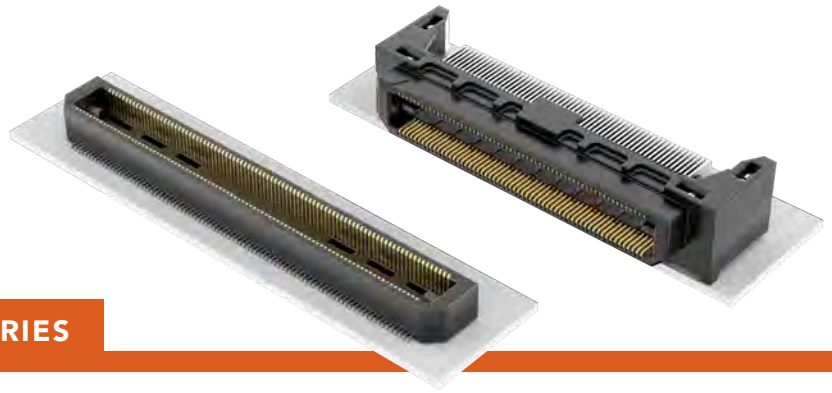

BTH
Mates:
BSH

SPECIFICATIONS

Insulator Material:
Black LCP
Contact Material:
Phosphor Bronze
Plating:
Au or Sn over
50 μ" (1.27 μm) Ni
Operating Temp Range:
-55 °C to +125 °C
Current Rating:
2.0 A per pin
(2 pins powered)
Voltage Rating:
175 VAC/247 VDC
Max Cycles:
100

PROCESSING

Lead-Free Solderable:
Yes
SMT Lead Coplanarity:
Vertical=
(0.10 mm) .004" max (030-090),
(0.15 mm) .006" max (120-150)*
Right-angle=
(0.15 mm) .006" max (030-090)*
*(.004" stencil solution
may be available; contact
ipg@samtec.com)
Board Stacking:
For applications requiring more
than two connectors per board
or 90 positions or higher,
contact ipg@samtec.com

ALSO AVAILABLE

Contact Samtec

30 μ" (0.76 μm) Gold
Edge Mount Capability
8 mm, 11 mm, 16 mm,
19 mm and 22 mm Stack
Height (Caution: Some
automatic placement/
inspection machines may
have component height
restrictions. Please consult
machinery specifications.)
(11 mm, 16 mm, 19 mm
and 22 mm not available
with 50 positions)



Note:
Some lengths, styles and
options are non-standard,
non-returnable.

BTH	NO. OF POSITIONS PER ROW	01	PLATING OPTION	D	A	OTHER OPTION
------------	---------------------------------	-----------	-----------------------	----------	----------	---------------------

**-030, -050, -060,
-090, -120, -150**

-F
= Gold Flash
on contact,
Matte Tin on tail

-L
= 10 μ" (0.25 μm)
Gold on contact,
Matte Tin on tail

-C*
= Electro-Polished Selective
50 μ" (1.27 μm) min
Au over 150 μ" (3.81 μm)
Ni on Signal Pins in contact
area, Matte Tin over
50 μ" (1.27 μm) min
Ni on all solder tails
(* -C Plating passes
10 year MFG testing)

-K
= (7.00 mm) .276"
DIA Polyimide
Film Pick
& Place Pad

-TR
= Tape & Reel
(120 positions
maximum)

-FR
= Full Reel
Tape & Reel
(must order
maximum
quantity per
reel; contact
Samtec for
quantity breaks)
(120 positions
maximum)

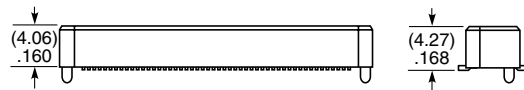
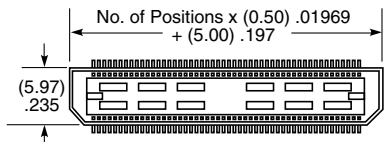

MATED HEIGHT

LEAD STYLE	MATED HEIGHT*
-01	(5.00 mm) .197"

*Processing conditions
will affect mated height.

BTH	NO. OF POSITIONS PER ROW	01	PLATING OPTION	D	RA	WT	OTHER OPTION
------------	---------------------------------	-----------	-----------------------	----------	-----------	-----------	---------------------

-030, -060, -090

-F
= Gold Flash on
contact, Matte
Tin on tail

-L
= 10 μ" (0.25 μm)
Gold on contact,
Matte Tin on tail

-K
= (7.00 mm)
.276" DIA
Polyimide
Film Pick &
Place Pad

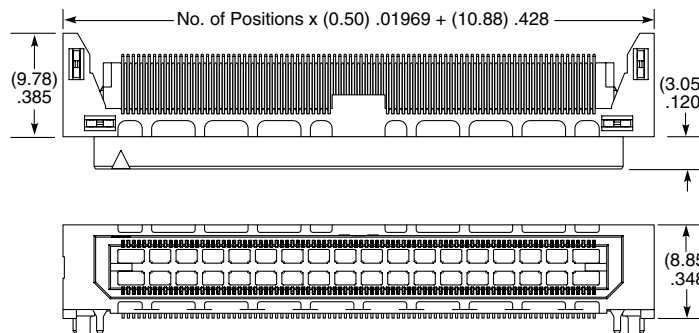

BASIC BLADE & BEAM SOCKET

(0.50 mm) .0197" PITCH • BSH SERIES

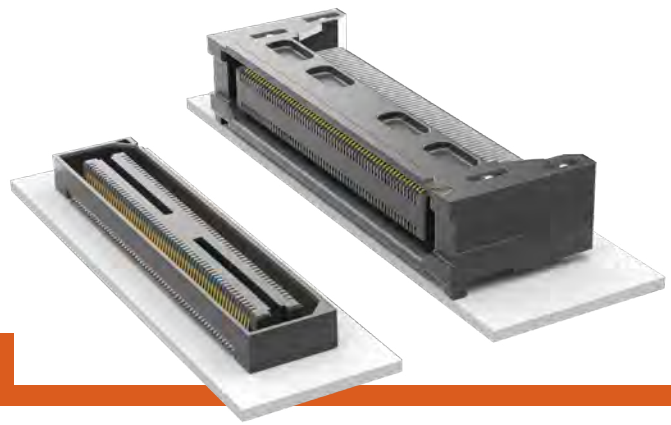

BSH
Mates:
BTH

SPECIFICATIONS

Insulator Material:
Black LCP
Contact Material:
Phosphor Bronze
Plating:
Au or Sn over
50 μ" (1.27 μm) Ni
Operating Temp Range:
-55 °C to +125 °C
Current Rating:
2 A per pin
(2 pins powered)
Voltage Rating:
175 VAC/247 VDC
Max Cycles:
100

PROCESSING

Lead-Free Solderable:
Yes
SMT Lead Coplanarity:
(0.10 mm) .004" max (030-090)
(0.15 mm) .006" max (120-150)*
*(.004" stencil solution
may be available; contact
ipg@samtec.com)
Board Stacking:
For applications requiring more
than two connectors per board
or 90 positions or higher,
contact ipg@samtec.com

ALSO AVAILABLE

Contact Samtec

30 μ" (0.76 μm) Gold
Edge Mount Capability
8 mm, 11 mm, 16 mm, 19 mm
and 22 mm Stack Height
(Caution: Some automatic
placement/inspection
machines may have
component height
restrictions. Please consult
machinery specifications.)
(11 mm, 16 mm, 19 mm
and 22 mm not available
with 50 positions)



Note:
Some lengths, styles and
options are non-standard,
non-returnable.

BSH	NO. OF POSITIONS PER ROW	01	PLATING OPTION	D	A	OTHER OPTION
------------	---------------------------------	-----------	-----------------------	----------	----------	---------------------

-030, -050, -060,
-090, -120, -150

-F
= Gold Flash
on contact,
Matte Tin on tail

-L
= 10 μ" (0.25 μm)
Gold on contact,
Matte Tin on tail

-C*
= Electro-Polished
Selective
50 μ" (1.27 μm) min
Au over 150 μ" (3.81 μm)
Ni on Signal Pins in
contact area,
Matte Tin over
50 μ" (1.27 μm) min
Ni on all solder tails
(*-C Plating passes
10 year MFG testing)

-TR
= Tape & Reel
(120 positions
maximum)

-FR
= Full Reel
Tape & Reel
(must order
maximum
quantity
per reel;
contact
Samtec for
quantity breaks
(120 positions
maximum)

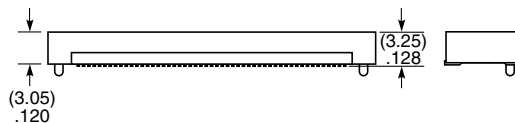
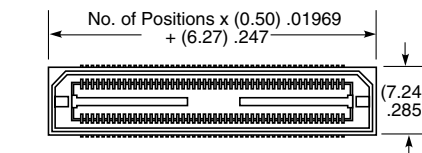

MATED HEIGHT

LEAD STYLE	MATED HEIGHT*
-01	(5.00 mm) .197"

*Processing conditions
will affect mated height.

BSH	NO. OF POSITIONS PER ROW	01	PLATING OPTION	D	RA	WT	OTHER OPTION
------------	---------------------------------	-----------	-----------------------	----------	-----------	-----------	---------------------

-030, -060, -090

-F
= Gold Flash
on contact,
Matte Tin on tail

-L
= 10 μ" (0.25 μm)
Gold on contact,
Matte Tin on tail

-GP
= Guide
Post

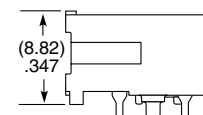
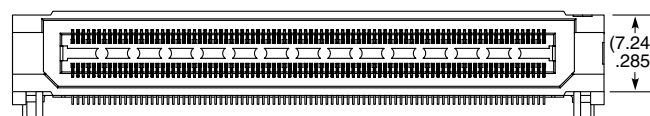
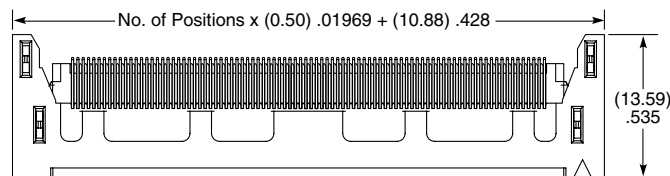

BASIC BLADE & BEAM HEADER & SOCKET

(0.635 mm) .025" PITCH • BTS/BSS SERIES

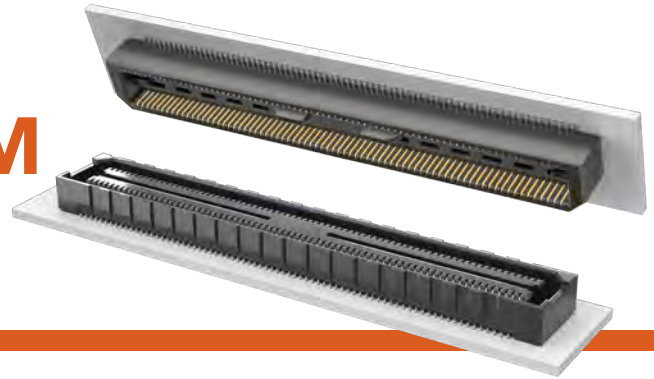

BTS
Mates:
BSS

BSS
Mates:
BTS

SPECIFICATIONS

Insulator Material:
Liquid Crystal Polymer
Terminal Material:
Phosphor Bronze
Contact Material:
Phosphor Bronze
Plating:
Au or Sn over 50 μ" (1.27 μm) Ni
Operating Temp Range:
-55 °C to +125 °C
Current Rating:
1.8 A per pin
(2 pins powered)

PROCESSING

Lead-Free Solderable:
Yes
SMT Lead Coplanarity:
(0.10 mm) .004" max
Board Stacking:
For applications requiring more than two connectors per board or 100 positions or higher, contact ipg@samtec.com

ALSO AVAILABLE

Contact Samtec

30 μ" (0.76 μm) Gold
Other platings
Other positions

MATED HEIGHT

LEAD STYLE	MATED HEIGHT*
-01	(5.00 mm) .197"

*Processing conditions will affect mated height.



Note:
Some lengths, styles and options are non-standard, non-returnable.

BTS	NO. OF POSITIONS PER ROW	01	PLATING OPTION	D	A	OTHER OPTION
------------	---------------------------------	-----------	-----------------------	----------	----------	---------------------

-025, -050,
-075, -100

-F
= Gold Flash on contact, Matte Tin on tail

-L
= 10 μ" (0.25 μm) Gold on contact, Matte Tin on tail

-K
= (7.00 mm) .275" DIA Polyimide Film Pick & Place Pad

-TR
= Tape & Reel (-100 positions max.)

-FR
= Full Reel Tape & Reel (must order max. quantity per reel; contact Samtec for quantity breaks) (-100 positions max.)

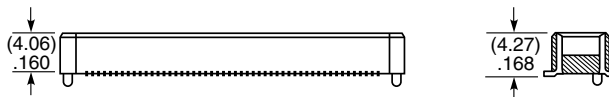
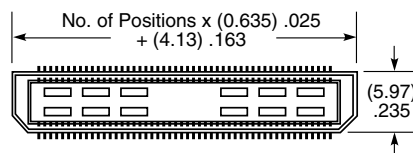

BSS	NO. OF POSITIONS PER ROW	01	PLATING OPTION	D	A	OTHER OPTION
------------	---------------------------------	-----------	-----------------------	----------	----------	---------------------

-025, -050,
-075, -100

-F
= Gold Flash on contact, Matte Tin on tail

-L
= 10 μ" (0.25 μm) Gold on contact, Matte Tin on tail

-TR
= Tape & Reel (-100 positions maximum)

-FR
= Full Reel Tape & Reel (must order maximum quantity per reel; contact Samtec for quantity breaks) (-100 positions maximum)

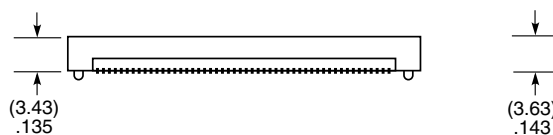
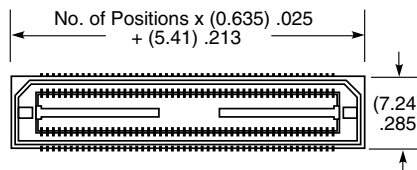

BASIC BLADE & BEAM HEADER & SOCKET

(0.80 mm) .0315" PITCH • BTE/BSE SERIES



BTE
Mates:
BSE

BSE
Mates:
BTE

SPECIFICATIONS

Insulator Material:
Liquid Crystal Polymer
Contact Material:
Phosphor Bronze
Plating:
Au or Sn over 50 μ" (1.27 μm) Ni
Operating Temp Range:
-55 °C to +125 °C
Current Rating:
2 A per pin
(2 pins powered)
Voltage Rating:
225 VAC/318 VDC
Max Cycles:
100

PROCESSING

Lead-Free Solderable:
Yes
SMT Lead Coplanarity:
(0.10 mm) .004" max (020-080)
(0.15 mm) .006" max (100-120)*
*(.004" stencil solution may be available; contact ipg@samtec.com)
Board Stacking:
For applications requiring more than two connectors per board or 80 positions or higher, contact ipg@samtec.com

ALSO AVAILABLE

Contact Samtec

30 μ" (0.76 μm) Gold
Edge Mount Capability
Friction Lock option
11 mm, 14 mm, 16.10 mm, 19.10 mm, 22 mm, 25 mm and 30 mm Stack Height (Caution: Some automatic placement/inspection machines may have component height restrictions. Please consult machinery specifications.)



Note:
Some lengths, styles and options are non-standard, non-returnable.

BTE	NO. OF POSITIONS PER ROW	LEAD STYLE	PLATING OPTION	D	A	OTHER OPTION
-----	--------------------------	------------	----------------	---	---	--------------

-020, -040, -060,
-080, -100, -120

Specify LEAD STYLE from chart

-F
= Gold Flash on contact, Matte Tin on tail

-L
= 10 μ" (0.25 μm) Gold on contact, Matte Tin on tail

-C*
= Electro-Polished Selective 50 μ" (1.27 μm) min Au over 150 μ" (3.81 μm) Ni on Signal Pins in contact area, Matte Tin over 50 μ" (1.27 μm) min Ni on all solder tails (*-C Plating passes 10 year MFG testing)

-K
= (7.00 mm) .275" DIA Polyimide Film Pick & Place Pad

-TR
= Tape & Reel (80 positions maximum)

-FR
= Full Reel Tape & Reel (must order maximum quantity per reel; contact Samtec for quantity breaks) (80 positions maximum)

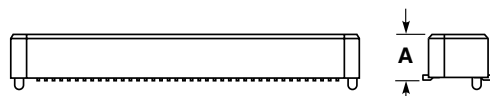
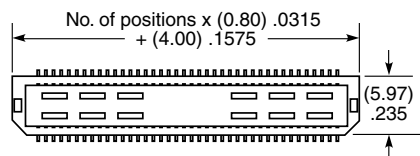

LEAD STYLE	A
-01	(4.27) .168
-02	(7.21) .284

MATED HEIGHT

LEAD STYLE	MATED HEIGHT*
-01	(5.00 mm) .197"
-02	(8.00 mm) .315"

*Processing conditions will affect mated height.

BSE	NO. OF POSITIONS PER ROW	01	PLATING OPTION	D	A	OTHER OPTION
-----	--------------------------	----	----------------	---	---	--------------

-020, -040, -060,
-080, -100, -120

-F
= Gold Flash on contact, Matte Tin on tail

-L
= 10 μ" (0.25 μm) Gold on contact, Matte Tin on tail

-C*
= Electro-Polished Selective 50 μ" (1.27 μm) min Au over 150 μ" (3.81 μm) Ni on Signal Pins in contact area, Matte Tin over 50 μ" (1.27 μm) min Ni on all solder tails (*-C Plating passes 10 year MFG testing)

-TR
= Tape & Reel (80 positions maximum)

-FR
= Full Reel Tape & Reel (must order maximum quantity per reel; contact Samtec for quantity breaks) (80 positions maximum)

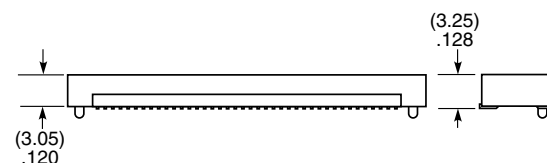
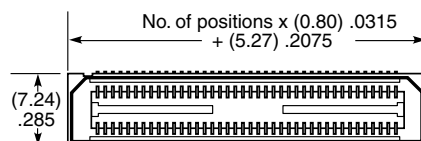

SMT MICRO HEADER & SOCKET

(0.80 mm) .0315" PITCH • FTE/CLE SERIES



FTE
Mates:
CLE

CLE
Mates:
FTE, AW



05
thru
90

Specify
LEAD
STYLE
from
chart

-G
= 10 μm
(0.25 μm)
Gold on
post,
Gold flash
on balance

-DV
= Dual
Vertical

-DH
= Dual
Horizontal
(50 positions
maximum)

Style -01 -DV only
(11 pins/row
minimum)

-ES
= End Shroud

-EC
= End Shroud with
Locking Clips
(Manual placement
required)

-EP
= End Shroud with
Guide Posts

-A
= Alignment
Pin
(5 positions
minimum)
Metal or
plastic at
Samtec
discretion
(-DV only)

-K
= (2.50 mm)
.098" DIA
Polyimide
Film Pick &
Place Pad
(-DH only)

SPECIFICATIONS

Insulator Material:
Black Liquid Crystal Polymer
Terminal Material:
Phosphor Bronze
Contact Material:
BeCu

Plating:
Au over 50 μm (1.27 μm) Ni
Operating Temp Range:
-55 °C to +125 °C

Current Rating (FTE/CLE):
2.2 A per pin
(2 pins powered)

Voltage Rating:
213 VAC/301 VDC

Insertion Depth (CLE):
Top Entry =
(1.73 mm) .068" to (3.18 mm) .125"
with (0.38 mm) .015"
wipe, or pass-through
Bottom Entry =
(3.23 mm) .127" minimum plus
board thickness

Max Cycles (CLE):
100 with 10 μm (0.25 μm) Au

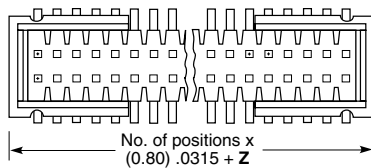
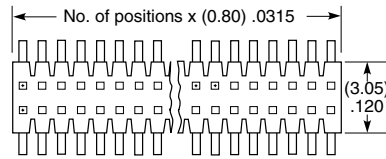

OPTION	Z	LEAD STYLE	A
-ES	(1.57) .062	-01	(1.90) .075
-EC	(4.11) .162	-02	(4.45) .175
-EP	(5.51) .217	-03	(3.05) .120

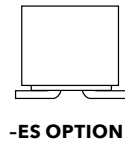
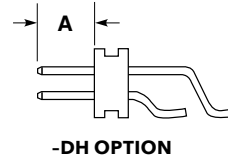
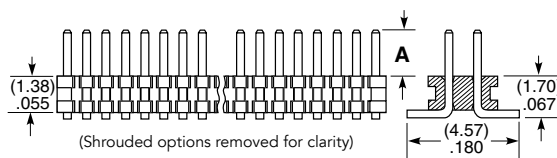
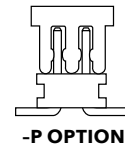

-P
= Plastic Pick
& Place Pad
(8 positions
minimum)
-DV only

-TR
= Tape & Reel

-FR
= Full Reel
Tape & Reel
(must order
max. quantity
per reel;
contact
Samtec for
quantity
breaks)

PROCESSING

Lead-Free Solderable:
Yes

SMT Lead Coplanarity (FTE):
-DV: (0.10 mm) .004" max
-DH: (0.10 mm) .004" max (05-25)
(0.15 mm) .006" max (26-50)*
*(.004" stencil solution
may be available; contact
ipg@samtec.com)

SMT Lead Coplanarity (CLE):
(0.10 mm) .004" max (04-65)
(0.15 mm) .006" max (66-90)*
*(.004" stencil solution
may be available; contact
ipg@samtec.com)



04 thru 90

-F
= Gold flash
on contact
and tail

-G
= 10 μm
(0.25 μm)
Gold on
contact
and tail

-A
= Alignment Pin
(4 positions minimum)
Metal or plastic at
Samtec discretion.

-K
= (3.50 mm) .138" DIA
Polyimide film
Pick & Place Pad
(8 positions minimum)

-P
= Metal Pick & Place Pad
(8 positions minimum)

-TR
= Tape & Reel

-FR
= Full Reel Tape & Reel
(must order max. quantity
per reel; contact Samtec
for quantity breaks)

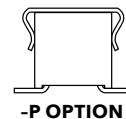
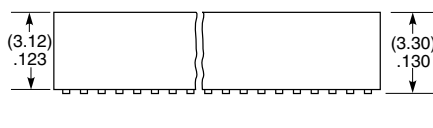
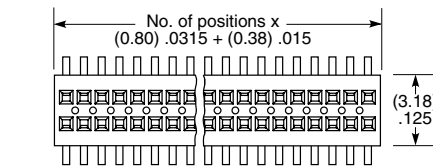

Note:
Some lengths, styles and
options are non-standard,
non-returnable.

SMT MICRO BOARD STACKER

(0.80 mm) .0315" PITCH • AW SERIES

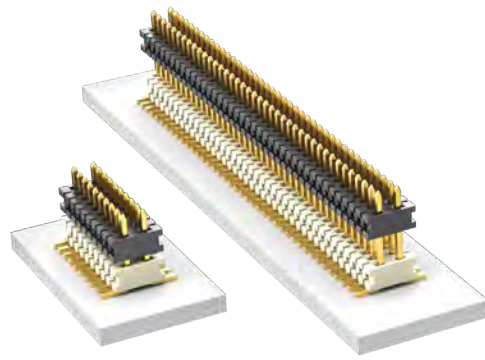

AW

Mates:
CLE

SPECIFICATIONS

Insulator Material:

Top: Black LCP
Bottom: Natural LCP

Terminal Material:

Phosphor Bronze

Plating:

Au over 50 μ " (1.27 μ m) Ni

Operating Temp Range:

-55 °C to +125 °C

PROCESSING

Lead-Free Solderable:

Yes

SMT Lead Coplanarity:

(0.10 mm) .004" max (05-40)

(0.15 mm) .006" max (41-90)*

*(.004" stencil solution

may be available; contact

ipg@samtec.com)

OPTIONS

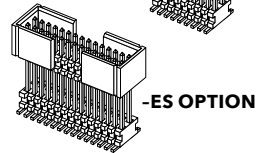
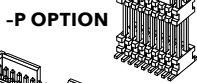
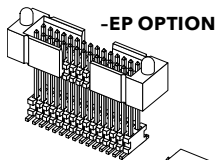

Notes:

For added mechanical stability, Samtec recommends mechanical board spacers be used in applications with gold or selective gold plated connectors. Contact ipg@samtec.com for more information.

Some lengths, styles and options are non-standard, non-returnable.

AW	NO. PINS PER ROW	03	PLATING OPTION	D	STACKER HEIGHT	POST HEIGHT	OTHER OPTION
----	------------------	----	----------------	---	----------------	-------------	--------------

05 thru 90

-G
= 10 μ "
(0.25 μ m)
Gold

-"XXX"
= Stacker
Height
(in inches)
(3.09 mm)
.122" to
(5.84 mm)
.230"

Example:
-175
= (4.45 mm)
.175"

-"XXX"
= Post
Height
(in inches)
(1.91 mm)
.075"
minimum

Example:
-075
= (1.91 mm)
.075"

-ES
= End Shroud
11 pins/row min.
(-075 Post
Height only)

-EP
= End Shroud
with Guide Post
(-075 Post
Height only)
11 pins/row min.

-A
= Alignment Pin
(4 positions min.)
(Available for
board stacks
between
(4.06 mm) .160" to
(5.84 mm) .230")
(Metal or plastic at
Samtec discretion.)

-P
= Pick & Place Pad
(8 positions min.)

-TR
= Tape & Reel
(84 positions max.)

-FR
= Full Reel
Tape & Reel
(must order max.
quantity per reel;
contact Samtec for
quantity breaks)
(84 positions max.)

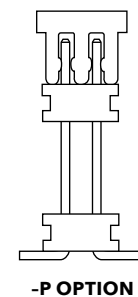
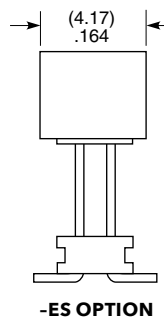
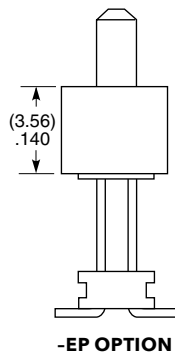
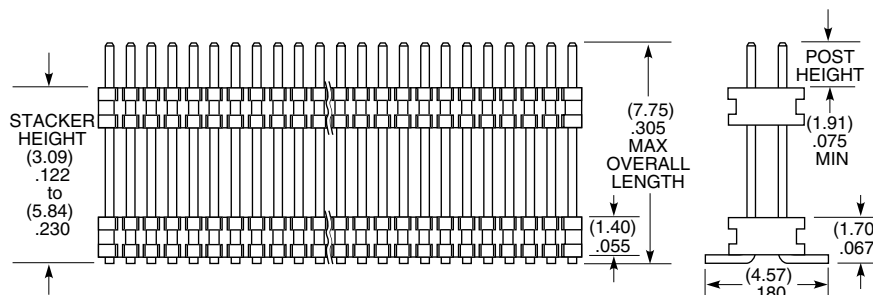
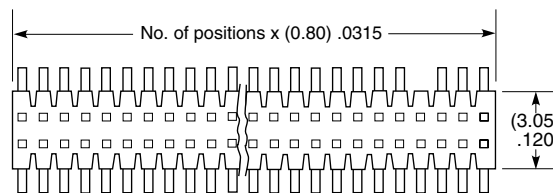

SMT MICRO TERMINAL STRIPS

(1.00 mm) .0394" PITCH • FTMH/FTM SERIES

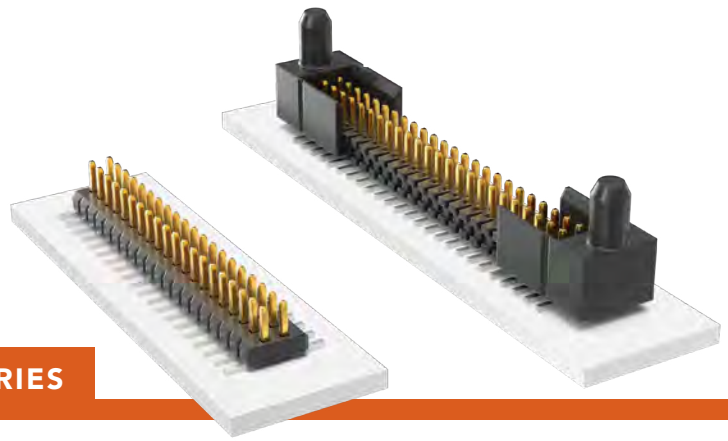

FTMH
Mates:
CLM, MLE

FTM
Mates:
CLM, MLE

SPECIFICATIONS

Insulator Material:
Black Liquid Crystal Polymer
Terminal Material:
Phosphor Bronze
Plating:
Sn or Au over
50 μ" (1.27 μm) Ni
Operating Temp Range:
-55 °C to +125 °C
Current Rating (FTMH/CLM):
3.1 A per pin
(2 pins powered)
Voltage Rating:
FTMH: 270 VAC /382 VDC

PROCESSING

Lead-Free Solderable:
Yes
SMT Lead Coplanarity:
-DV: (0.10 mm) .004" max
-DH: (0.10 mm) .004" max (05-25)
(0.15 mm) .006" max (26-50)*
*(.004" stencil solution may be available; contact ipg@samtec.com)

FTMH	1	NO. PINS PER ROW	LEAD STYLE	PLATING OPTION	ROW OPTION	FLEX SHROUD OPTION	OTHER OPTION
------	---	------------------	------------	----------------	------------	--------------------	--------------

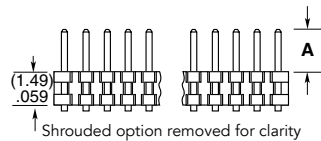
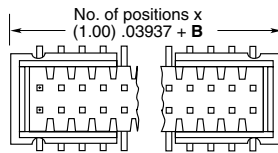
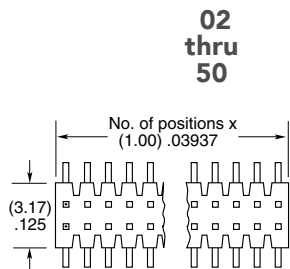

-02
= (1.91 mm) .075" Post (Mates with MLE)

-03
= (1.65 mm) .065" Post (Mates with CLM)

-F
= Gold flash on post, Matte Tin on tail

-DV
= Dual Vertical

(-DV only with 9 pins/row minimum)

-ES
= End Shroud

-EC
= End Shroud with Locking Clip (Manual placement required)

-EP
= End Shroud with Guide Post (Use only when mating with CLM)

-A
= Alignment Pin (3 positions min.) Metal or plastic at Samtec discretion (-DV only)

-K
= (2.50 mm) .098" DIA Polyimide Film Pick & Place Pad (-DH only)

-P
= Plastic Pick & Place Pad (6 positions min.) (-DV only)

-TR
= Tape & Reel

-FR
= Full Reel Tape & Reel (must order max. quantity per reel; contact Samtec for quantity breaks)

OPTION	B
-ES	(1.57) .062
-EC	(4.06) .160
-EP	(5.49) .216

LEAD STYLE	A
-02	(1.91) .075
-03	(1.65) .065

-DV OPTION

-DH OPTION

FTM	1	NO. PINS PER ROW	LEAD STYLE	PLATING OPTION	DV	FLEX SHROUD OPTION	OTHER OPTION
-----	---	------------------	------------	----------------	----	--------------------	--------------

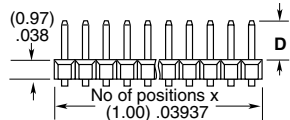
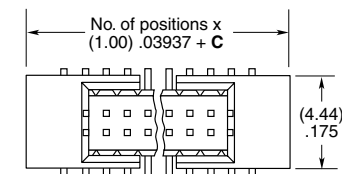
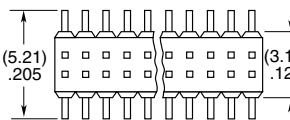
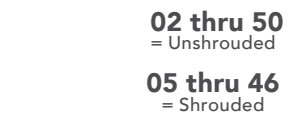

-02
= (1.91 mm) .075" Post (Mates with MLE)

-03
= (1.65 mm) .065" Post (Mates with CLM)

-F
= Gold flash on post, Matte Tin on tail

-L
= 10 μ" (0.25 μm) Gold on post, Matte Tin on tail

-S
= End Shroud (05 positions minimum). Molded or press-fit shroud at Samtec's discretion

-SA
= End Shroud with Alignment Pins (05 through 46 positions)

-P
= Plastic Pick & Place Pad (7 positions min.)

-TR
= Tape & Reel

-FR
= Full Reel Tape & Reel (must order max. quantity per reel; contact Samtec for quantity breaks)

OPTION	C
-S	(4.00) .157
-SA	(7.00) .276

LEAD STYLE	D
-02	(1.91) .075
-03	(1.65) .065

ALSO AVAILABLE

Contact Samtec

End shrouds with board locks
Molded end shrouds for 05 through 08 positions
Other platings



Note:
Some lengths, styles and options are non-standard, non-returnable.

FLEX STACK

SMT MICRO BOARD HEADER

(1.00 mm) .0394" PITCH • MW SERIES

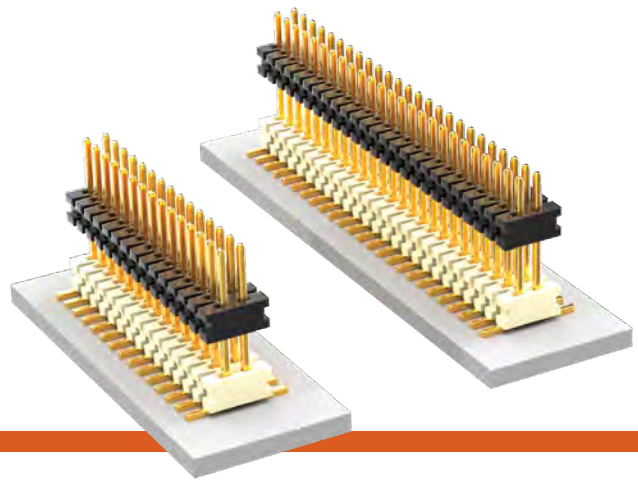

MW

Mates:
CLM, MLE

SPECIFICATIONS

Insulator Material:
Top: Black LCP
Bottom: Natural LCP
Terminal Material:
Phosphor Bronze
Plating:
Au over 50 μ" (1.27 μm) Ni
Operating Temp Range:
-55 °C to +125 °C

PROCESSING

Lead-Free Solderable:
Yes
SMT Lead Coplanarity:
(0.10 mm) .004" max (02-30)
(0.15 mm) .006" max (31-50)*
*(.004" stencil solution
may be available; contact
ipg@samtec.com)

ALSO AVAILABLE

Contact Samtec

End shrouds
End shrouds with
guide posts

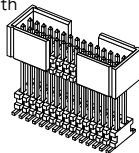

MW	NO. PINS PER ROW	03	PLATING OPTION	D	STACKER HEIGHT	POST HEIGHT	OPTION
----	------------------	----	----------------	---	----------------	-------------	--------

02 thru 50

-F
= Gold flash on contact, Matte Tin on tail

-G
= 10 μ" (0.25 μm) Gold on contact, Gold flash on tail

-"XXX"
= Stacker Height (in inches)

(2.41 mm) .095" to (6.22 mm) .245"

Example:
-245 = (6.22 mm) .245"

-"XXX"
= Post Height (in inches)

(1.65 mm) .065" minimum

Example:
-065 = (1.65 mm) .065"

-A
= Alignment Pin (5 positions minimum) Metal or plastic at Samtec's discretion

-P
= Pick & Place Pad (7 positions minimum)

-TR
= Tape & Reel

-FR
= Full Reel Tape & Reel (must order maximum quantity per reel; contact Samtec for quantity breaks)

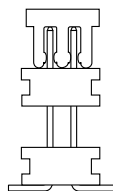
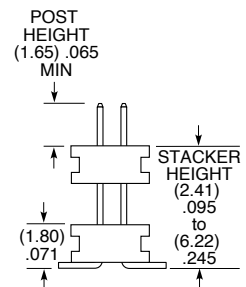
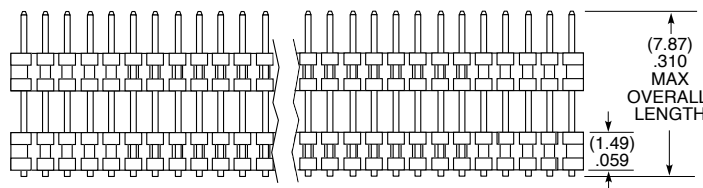
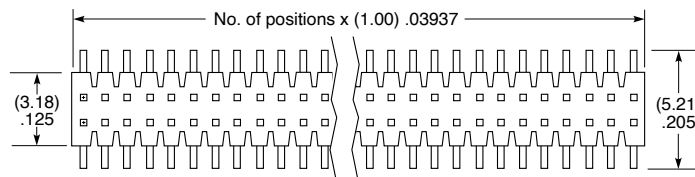

-P OPTION

APPLICATION

EXAMPLES		
LEAD STYLE		MATED HEIGHT*
MW	CLM	
-163-065	-02	(6.35 mm) .250"
-233-065		(8.13 mm) .320"

*Processing conditions will affect mated height.

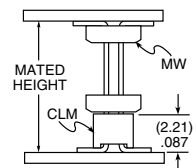

Notes:

For added mechanical stability, Samtec recommends mechanical board spacers be used in applications with gold or selective gold plated connectors. Contact ipg@samtec.com for more information.

This Series is non-standard, non-returnable.

RUGGED RELIABLE MICRO SOCKETS

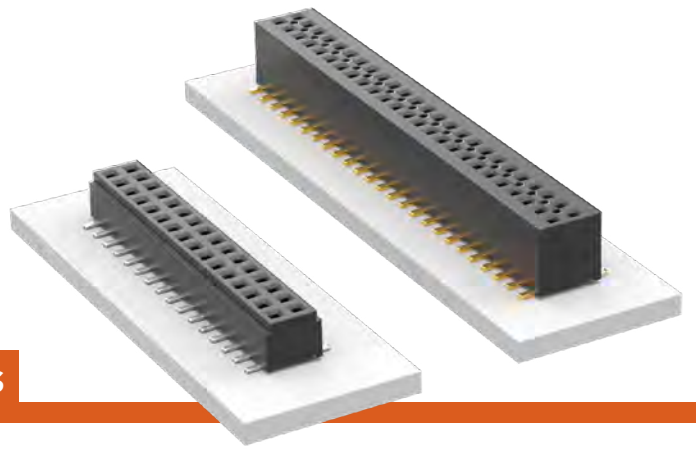

(1.00 mm) .0394" PITCH • CLM/MLE SERIES

CLM

Mates:
FTM, FTMH, MW

MLE

Mates:
FTM, FTMH, MW

SPECIFICATIONS

Insulator Material: Black LCP
Contact Material:
 CLM: Phosphor Bronze
 MLE: BeCu
Plating:
 CLM: Au or Sn over
 50 μ" (1.27 μm) Ni
 MLE: Au over 10 μ" (0.25 μm) Ni
Operating Temp Range:
 -55 °C to +125 °C
Current Rating (CLM/FTMH):
 3.1 A per pin
 (2 pins powered)
Current Rating (MLE/FTMH):
 2.9 A per pin (2 pins powered)
Max Cycles:
 CLM: 100 with 10 μ" (0.25 μm) Au
Voltage Rating:
 CLM: 270 VAC/382 VDC
 MLE: 310 VAC/438 VDC
Insertion Depth:
 CLM:
 Top Entry = (1.40 mm) .055" min.,
 Bottom Entry =
 (2.41 mm) .095" min.
 (Add board thickness for
 correct post OAL)
 MLE:
 (1.63 mm) .064" to
 (3.18 mm) .125" with
 (0.38 mm) .015" wipe,
 pass-through, or (2.44 mm) .096"
 minimum for bottom entry

PROCESSING

Lead-Free Solderable:
 Yes
SMT Lead Coplanarity:
 (0.10 mm) .004" max (02-25)
 (0.15 mm) .006" max (26-50)*
 *(.004" stencil solution
 may be available; contact
 ipg@samtec.com)

ALSO AVAILABLE

Contact Samtec

Alignment pin
 Other Gold plating options



Note:
 Some lengths, styles and
 options are non-standard,
 non-returnable.



02 thru 50

-F
 = Gold flash on
 contact,
 Matte Tin on tail

-L
 = 10 μ" (0.25 μm)
 Gold on contact,
 Matte Tin on tail

-BE
 = Bottom Entry
 (Required for bottom entry)

-K
 = (3.50 mm) .138" DIA
 Polyimide film
 Pick & Place Pad
 (3 positions minimum)

-P
 = Pick & Place Pad
 (7 positions minimum)

-PA
 = Pick & Place Pad with
 integral Alignment Pin

-TR
 = Tape & Reel

-FR
 = Full Reel Tape & Reel
 (must order maximum
 quantity per reel;
 contact Samtec for
 quantity breaks)

PIN/ROW	A
04-15	(3.56) .140
16-50	(7.11) .280

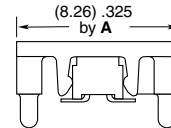
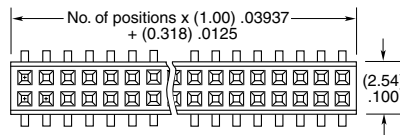

-PA

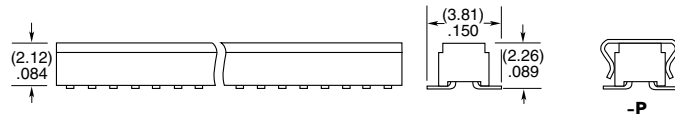

-P



02 thru 50

-G
 = 10 μ"
 (0.25 μm)
 Gold

-A
 = Alignment Pin
 (3 positions minimum)
 Metal or plastic
 at Samtec discretion

-K
 = (4.00 mm) .1575" DIA
 Polyimide film
 Pick & Place Pad
 (5 positions minimum)

-P
 = Metal Pick & Place Pad
 (5 positions minimum)

-TR
 = Tape & Reel

-FR
 = Full Reel Tape & Reel
 (must order maximum
 quantity per reel;
 contact Samtec for
 quantity breaks)

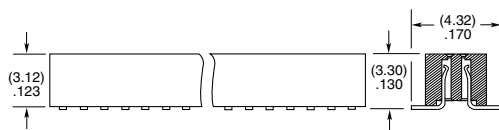
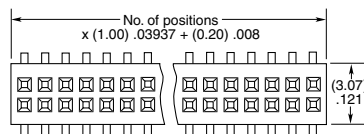

-P

-A

QUAD ROW SMT TERMINAL & SOCKET

(1.27 mm) .050" PITCH • TOLC/SOLC SERIES

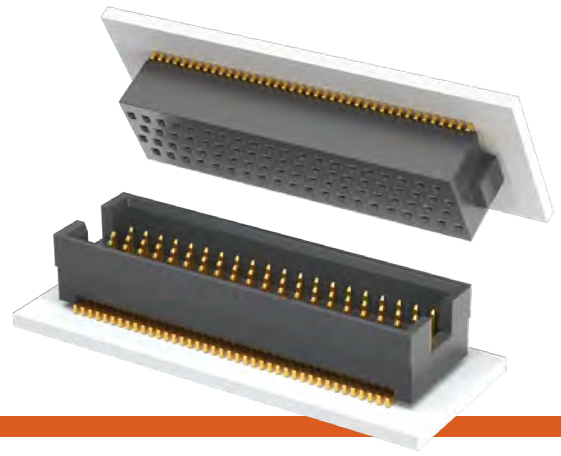

TOLC
Mates:
SOLC

SOLC
Mates:
TOLC

SPECIFICATIONS

Insulator Material:
Black Liquid Crystal Polymer
Contact Material:
Phosphor Bronze
Plating:
Au over 50 μm (1.27 μm) Ni
Operating Temp Range:
-55 °C to +125 °C
Current Rating:
3.9 A per pin
(2 pins powered)
Voltage Rating:
188 VAC/266 VDC
Insertion Depth (SOLC):
(1.68 mm) .066" to
(3.61 mm) .142" with
(0.38 mm) .015" wipe
Max Cycles (SOLC):
100+

PROCESSING

Lead-Free Solderable:
Yes
SMT Lead Coplanarity:
(0.10 mm) .004" max (05-35)
(0.15 mm) .006" max (40-50)*
*(.004" stencil solution
may be available; contact
ipg@samtec.com)

ALSO AVAILABLE
Contact Samtec

Other sizes
Other platings

Note:
Some lengths, styles and
options are non-standard,
non-returnable.

TOLC	1	NO. PINS PER ROW	LEAD STYLE	PLATING OPTION	Q	OTHER OPTION
-------------	----------	-------------------------	-------------------	-----------------------	----------	---------------------

05, 10, 15, 20, 25,
30, 35, 40, 45, 50
(Standard Sizes)

Specify
LEAD
STYLE
from
chart

-F
= Gold flash
on contact,
Gold flash
on tail
-L
= 10 μm
(0.25 μm)
Gold on
contact,
Gold flash
on tail

-A
= Alignment Pin
(N/A with -LC)
-LC
= Locking Clip
(N/A with -A)
(Manual
placement required)
-K
= (9.00 mm) .354" DIA
Polyimide film
Pick & Place Pad

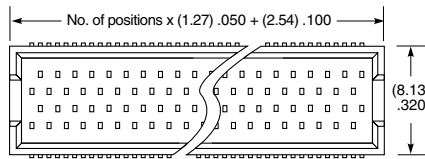

LEAD STYLE	A	MATED HEIGHT
-02	(5.59) .220	(6.35) .250
-12	(7.24) .285	(8.00) .315
-22	(9.25) .364	(10.00) .394
-32	(11.23) .442	(12.00) .472

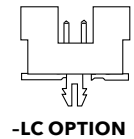
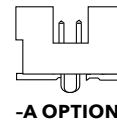
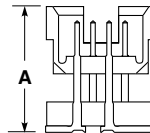
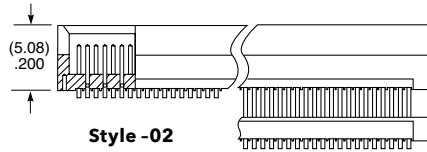

SOLC	1	NO. PINS PER ROW	02	PLATING OPTION	Q	OTHER OPTION
-------------	----------	-------------------------	-----------	-----------------------	----------	---------------------

05, 10, 15, 20, 25,
30, 35, 40, 45, 50
(Standard Sizes)

-F
= Gold flash
on contact,
Gold flash
on tail
-L
= 10 μm (0.25 μm)
Gold on contact,
Gold flash
on tail

-A
= Alignment Pin
(N/A with -LC)
-LC
= Locking Clip
(N/A with -A)
(Manual
placement required)
-K
= (7.00 mm) .276" DIA
Polyimide film
Pick & Place Pad
-P
= Pick & Place Pad
-TR
= Tape & Reel
-FR
= Full Reel Tape & Reel
(must order max.
quantity per reel;
contact Samtec for
quantity breaks)

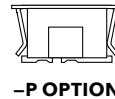
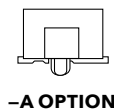
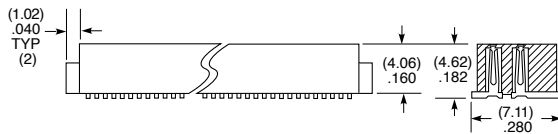
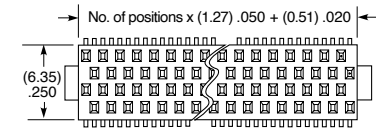

SURFACE MOUNT MICRO HEADER

(1.27 mm) .050" PITCH • FTSH SERIES

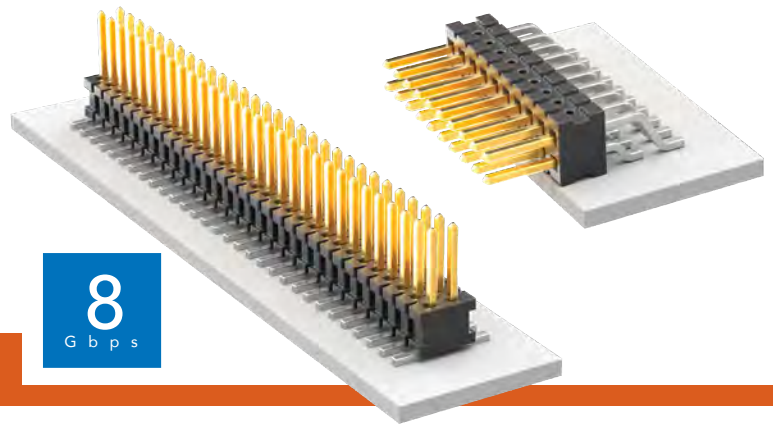

FTSH

Board Mates:

CLP, FLE

Cable Mates:

FFSD, FFTP

SPECIFICATIONS

Insulator Material:

Black Liquid Crystal Polymer

Terminal Material:

Phosphor Bronze

Plating:

Sn or Au over

50 μ " (1.27 μ m) Ni

Operating Temp Range:

-55 °C to +125 °C

Current Rating (FTSH/CLP):

3.4 A per pin

(2 pins powered)

Current Rating (FTSH/FLE):

2.9 A per pin

(2 pins powered)

Voltage Rating:

280 VAC/396 VDC

PROCESSING

Lead-Free Solderable:

Yes

SMT Lead Coplanarity:

-MT & -DV Tail Option:

(0.10 mm) .004" max (02-25)

-MT & -DH Tail Option:

(0.15 mm) .006" max (26-50)*

*(.004" stencil solution

may be available; contact

ipg@samtec.com)

FTSH	1	NO. PINS PER ROW	LEAD STYLE	PLATING OPTION	TAIL OPTION	OPTION	FLEX SHROUD OPTIONS	OTHER OPTIONS
------	---	------------------	------------	----------------	-------------	--------	---------------------	---------------

02
thru
50

-01
= (3.05 mm)
.120" Post
(Mates with
FFSD)

-02
= (1.91 mm)
.075" Post
(Mates with
FLE)

-03
= (1.65 mm)
.065" Post
(Mates with
CLP-D)

-04
= (3.81 mm)
.150" Post
(Mates with
CLP-DH)

-05
= (4.32 mm)
.170" Post
(Mates with
CLP-BE)

-F
= Gold flash
on post,
Matte Tin
on tail

-L
= 10 μ "
(0.25 μ m)
Gold
on post,
Matte Tin
on tail

-DV
= Double
Vertical

-DH
= Double
Horizontal
(Styles
-01, -02 &
-04 only)

-MT
= Mixed
Technology
(Styles
-01, -02 &
-04 only)

Leave Blank
for -DH &
-MT

-"XXX"
= Polarized
Position
(Specify
position
of
omitted
pin)
(Not
available
with -EX
options)

(Style -02 & -03
only, -DH & -MT
not available)
9 pins/row
minimum
(Other positions
available. Call
Samtec.)

-ES
= End Shroud

-EC
= End Shroud
with Locking
Clip
(Manual
placement
required)

-EP
= End Shroud
with Guide Post

-EL
= End Shroud with
Board Lock
(Boards are
positively locked
and cannot be
unmated)

-EJ
= Ejector Shroud
(Style -01 only)
-DH & -MT
not available
10 pins/row
minimum
25 pins/row
maximum

-K
= Keying
Shroud for
mating
with FFSD
(Style -01 only,
05 thru 25
pins/row only.
13, 17, 20 &
25 only with
-EJ option)
(-DV only)

-A
= Alignment
Pin
(-DV 3 positions
minimum)
(-DH 5 positions
minimum)
(Metal or
plastic at
Samtec
discretion)

-C
= (5.00 mm)
.197" DIA
Polyimide film
Pick & Place
Pad
(-DH only)

-P
= Pick &
Place Pad
(-DV 4 positions
minimum)
(-DH & -MT
not available)

-TR
= Tape & Reel
(Flex Shroud
options
not available
except -ES
& -EJ)

-FR
= Full Reel
Tape & Reel
(must order
maximum
quantity
per reel;
contact
Samtec for
quantity breaks)

OPTION	Z
-ES	(2.57) .101
-EJ	(15.77) .621
-EC	(3.33) .131
-EP	(5.87) .231
-EL	(6.53) .257

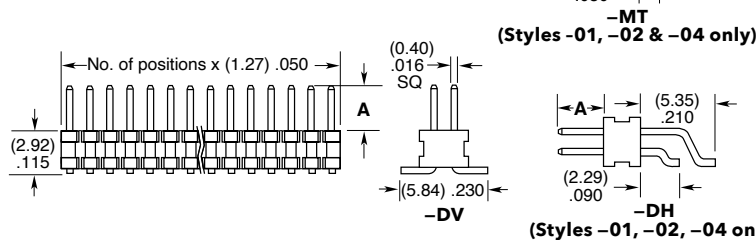
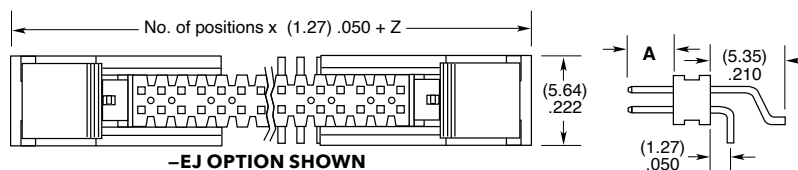
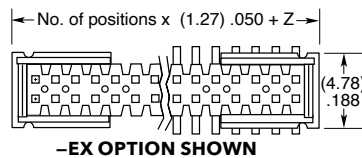

LEAD STYLE	A
-01	(3.05) .120
-02	(1.91) .075
-03	(1.65) .065
-04	(3.81) .150
-05	(4.32) .170

ALSO AVAILABLE

Contact Samtec

Molded Pick & Place pads

Latches

Other platings



Notes:

Severe Environment
Testing qualified; aligns
with MIL-DTL-55302.
Visit samtec.com/set

Some sizes, styles and
options are non-standard,
non-returnable.

See SFM/TFM for positive
alignment feature.

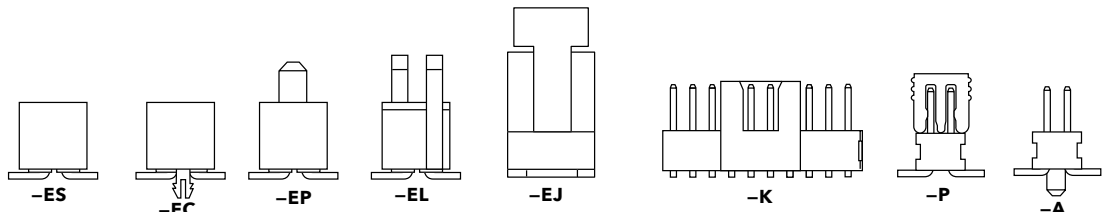

THROUGH-HOLE MICRO HEADER

(1.27 mm) .050" PITCH • FTSH SERIES

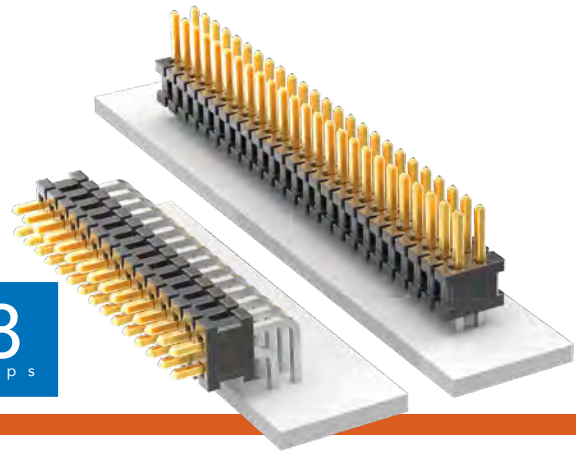

FTSH

Board Mates:

CLP, FLE

Cable Mates:

FFSD, FFTP

SPECIFICATIONS

Insulator Material:

Black Liquid Crystal Polymer

Terminal Material:

Phosphor Bronze

Plating:

Sn or Au over 50 μ" (1.27 μm) Ni

Operating Temp Range:

-55 °C to +125 °C

Current Rating (FTSH/CLP):

3.4 A per pin

(2 pins powered)

Current Rating (FTSH/FLE):

2.9 A per pin

(2 pins powered)

Voltage Rating:

280 VAC/396 VDC

PROCESSING

Lead-Free Solderable:

Yes

LOCKING CLIP

For single mating cycle with the FFSD. Specify

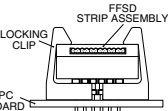

-LC after tail option. Lead Style -01 and 10 pins/row minimum. 5-9 pins/row not available in combination with keying shroud (-K).

ALSO AVAILABLE

Contact Samtec

Molded Pick & Place pads

Other platings



Notes:

Severe Environment Testing qualified; aligns with MIL-DTL-55302. Visit samtec.com/set

Some sizes, styles and options are non-standard, non-returnable.

See SFM/TFM for positive alignment feature.

FTSH	1	NO. PINS PER ROW	LEAD STYLE	PLATING OPTION	D	OPTION	TAIL OPTION	OTHER OPTIONS
------	---	------------------	------------	----------------	---	--------	-------------	---------------

02 thru 50

Specify LEAD STYLE from chart

-F
= Gold flash on post, Matte Tin on tail

-L
= 10 μ" (0.25 μm) Gold on post, Matte Tin on tail

Leave blank for Right-angle

-"XXX"
= Polarized Position (Specify position of omitted pin) (Not available with -EX options)

Leave blank for straight tail

-RA
= Right-angle

-ES
= End Shroud (Style -02 & -03) 9 pins/row minimum

-EP
= End Shroud with Guide Post (Style -02 & -03) 9 pins/row minimum

-EL
= End Shroud with Board Lock (Style -02 & -03) 9 pins/row minimum

-EJ
= Ejector Shroud (Style -01 only) 10 pins/row minimum 25 pins/row maximum -RA not available

-K
= Keying Shroud for mating with FFSD (Style -01 only, 05 thru 25 pins/row only. 13, 17, 20 & 25 only with -EJ option)

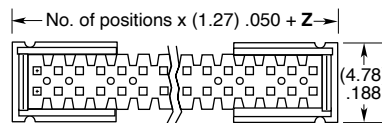

-EX OPTION SHOWN

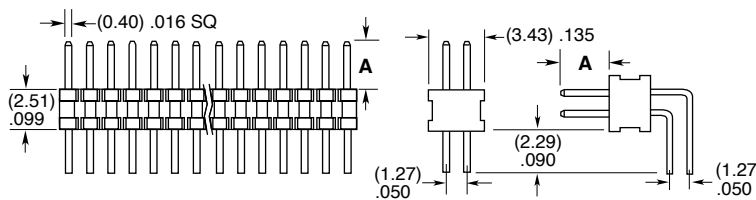
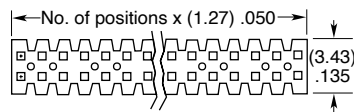

OPTION	Z
-ES	(1.55) .061
-EJ	(15.77) .621
-EP	(5.87) .231
-EL	((6.53) .257

LEAD STYLE	A	MATES WITH
-01	(3.05) .120	FFSD
-02	(1.91) .075	FLE
-03	(1.65) .065	CLP-D
-04	(3.81) .150	N/A

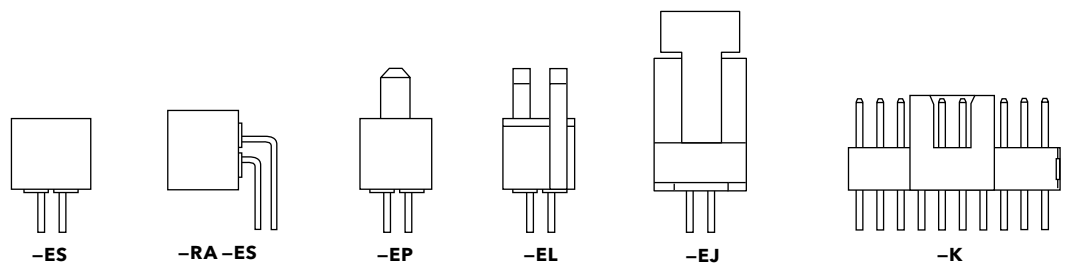

MICRO LOW PROFILE TERMINAL STRIPS

(1.27 mm) .050" PITCH • FTS SERIES

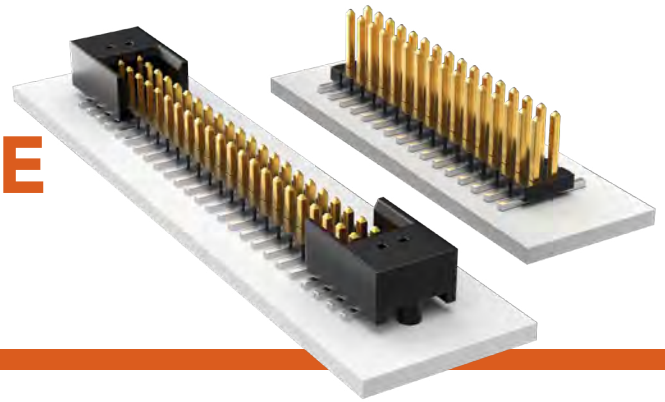

FTS

Board Mates:
CLP, FLE

Cable Mates:
FFSD

SPECIFICATIONS

Insulator Material:
Black Liquid Crystal Polymer
Terminal Material:
Phosphor Bronze
Operating Temp Range:
-55 °C to +125 °C
Plating:
Sn or Au over 50 μ" (1.27 μm) Ni
Current Rating:
3.4 A per pin
(2 pins powered)

PROCESSING

Lead-Free Solderable:
Yes
SMT Lead Coplanarity:
.004" (0.10 mm) max

ALSO AVAILABLE

Contact Samtec

Alignment pin

OPTIONS

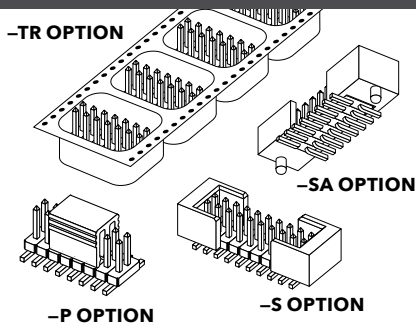

FTS	1	NO. PINS PER ROW	LEAD STYLE	PLATING OPTION	ROW OPTION	OTHER OPTION
-----	---	------------------	------------	----------------	------------	--------------

02 thru 50
(except -S & -SA
option = 05 thru 46)

-01
= (3.05 mm)
.120" Post
(Mates with FFSD)

-02
= (1.91 mm)
.075" Post
(Mates with FLE)

-03
= (1.65 mm)
.065" Post
(Mates with CLP)

-04
= (3.81 mm)
.150" Post
(-D & -DV only)

-F
= Gold flash
on post,
Matte Tin
on tail

-L
= 10 μ"
(0.25 μm)
Gold on post,
Matte Tin
on tail

-D
= Double
Through-hole

-DV
= Double
Vertical SMT

-S
= Single
Through-hole

-SV
= Single
Vertical SMT

(-D & -DV only)

-SA
= End Shroud
with Alignment Pin
(05 thru 46 positions.
Style -02 & -03 only)

-S
= End Shroud
(05 thru 46 positions.
Style -02 & -03 only)

-P
= Pick & Place Pad
(04 positions min.)

-TR
= Tape & Reel
(-DV only)
(Required callout for
positions 02 thru 04)

-FR
= Full Reel
Tape & Reel
(must order max.
quantity per reel;
contact Samtec for
quantity breaks)
(-DV only)

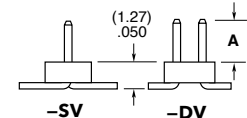
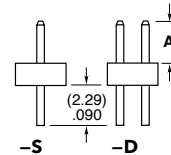
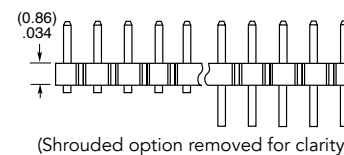
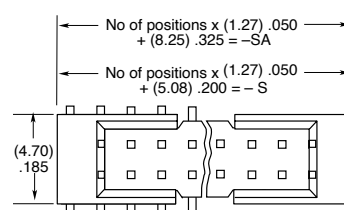
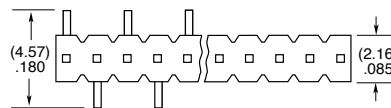
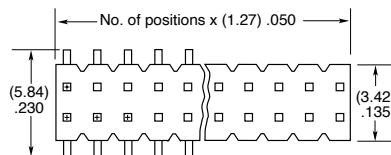

LEAD STYLE	A
-01	(3.05) .120
-02	(1.91) .075
-03	(1.65) .065
-04	(3.81) .150

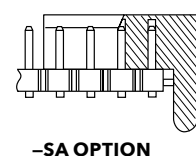
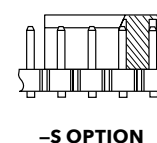

Note:
Some lengths, styles and
options are non-standard,
non-returnable.

FLEX STACK

MICRO BOARD STACKER

(1.27 mm) .050" PITCH • FW SERIES

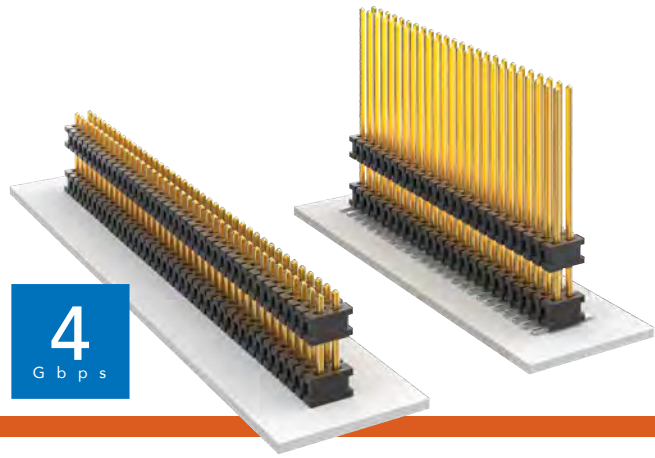

FW
Board Mates:
 CLP, FLE
Cable Mates:
 FFSD

FW	NO. OF PINS PER ROW	LEAD STYLE	PLATING OPTION	D	STACKER HEIGHT	POST HEIGHT	OPTION
----	---------------------	------------	----------------	---	----------------	-------------	--------

02 thru 50

Specify LEAD STYLE from chart

-F
 = Gold flash on post, Matte Tin on tail

-L
 = 10 μm (0.25 μm) Gold on post, Matte Tin on tail

-G
 = 10 μm (0.25 μm) Gold on post, Gold flash on tail

-"XXX"
 = Stacker Height (in inches)
 Example: $-.250 = (6.35 \text{ mm}) .250"$

-"XXX"
 = Post Height (in inches)
 (1.65 mm) .065" minimum
 Example: $-.065 = (1.65 \text{ mm}) .065"$

-ES
 = End Shroud (-075 post height only. Mate only with CLP) (5.46 mm) .215" to (15.49 mm) .610" stacker height only 9 pins/row min.

-EP
 = End Shroud with Guide Post (-075 post height only. Mate only with CLP) (5.46 mm) .215" to (15.49 mm) .610" stacker height only 9 pins/row min.

-A
 = Alignment Pin (3 positions min.) (5.46 mm) .215" to (15.75 mm) .620" stacker height only (SMT only)

-P
 = Pick & Place Pad (5 positions min.) (SMT only)

-TR
 = Tape & Reel (Max overall height = Post+Stacker Height+Pad+ Alignment Pin = (17.78) .700") (SMT only)

-FR
 = Full Reel Tape & Reel (must order max. quantity per reel; contact Samtec for quantity breaks) (SMT only)

SPECIFICATIONS

Insulator Material:
 Black Liquid Crystal Polymer
Terminal Material:
 Phosphor Bronze
Plating:
 Sn or Au over 50 μm (1.27 μm) Ni
Operating Temp Range:
 -55 °C to +125 °C

PROCESSING

Lead-Free Solderable:
 Yes
SMT Lead Coplanarity:
 (0.10 mm) .004" max (02-30)
 (0.15 mm) .006" max (31-50)*
 *(.004" stencil solution may be available; contact ipg@samtec.com)

LEAD STYLE	STACKER HEIGHT	STACKER + POST
-03	(5.46) to (8.51) .215 to .335	(7.11) to (10.16) .280 to .400
-05	(8.64) to (15.49) .340 to .610	(10.29) to (17.15) .405 to .675

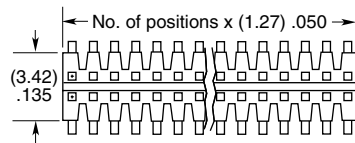

SURFACE MOUNT

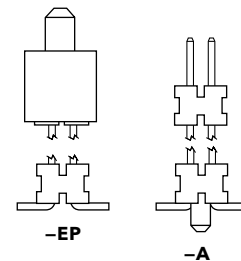
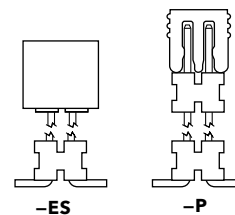
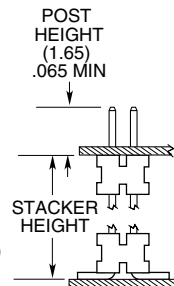
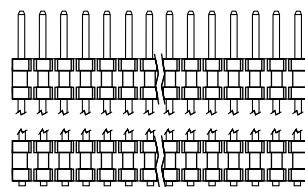

MATED HEIGHT

FW LEAD STYLE	CLP LEAD STYLE	MATED HEIGHT*
FW-XX-03-X-X-233-065	-02	(8.13 mm) .320"
FW-XX-03-X-X-303-065		(9.91 mm) .390"

*Processing conditions will affect mated height.

ALSO AVAILABLE

Contact Samtec

Smaller stack heights

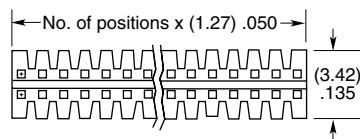

THROUGH-HOLE

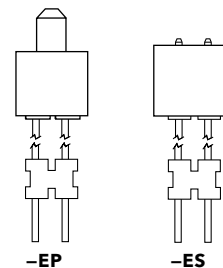
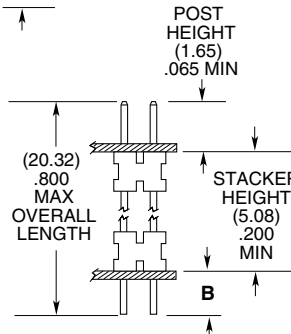
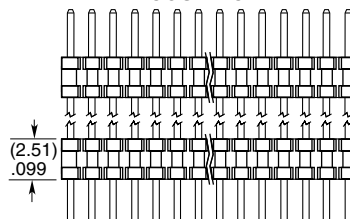

LEAD STYLE	TAIL (B)
-01	(1.14) .045
-02	(1.91) .075
-04	(2.29) .090

Notes:
 For added mechanical stability, Samtec recommends mechanical board spacers be used in applications with gold or selective gold plated connectors. Contact ipg@samtec.com for more information.

This Series is non-standard, non-returnable.

LOW PROFILE DUAL WIPE SOCKET

8
Gbps

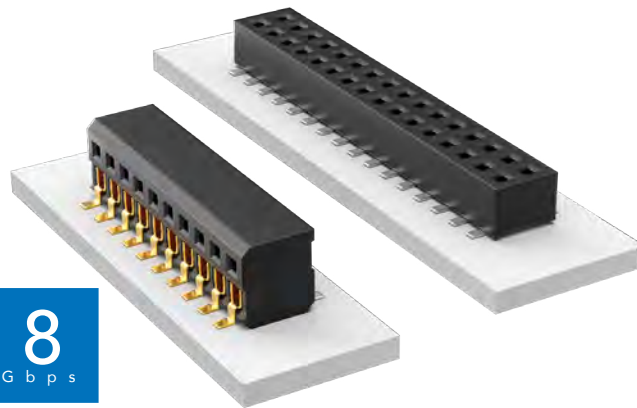

(1.27 mm) .050" PITCH • CLP SERIES

CLP

Mates:

FTSH, FTS, FW



SPECIFICATIONS

Insulator Material:

Black Liquid Crystal Polymer

Contact Material:

Phosphor Bronze

Plating:

Sn or Au over

50 μ" (1.27 μm) Ni

Operating Temp Range:

-55 °C to +125 °C

Current Rating (CLP/FTSH):

3.4 A per pin

(2 pins powered)

Voltage Rating:

280 VAC/396 VDC

Insertion Depth:

Top Entry =

(1.40 mm) .055" minimum

Bottom Entry =

(2.41 mm) .095" minimum

plus board thickness

DH Entry =

(2.31 mm) .091" to (2.67 mm) .105"

Max Cycles:

100 with 10 μ" (0.25 μm) Au

PROCESSING

Lead-Free Solderable:

Yes

SMT Lead Coplanarity:

(0.10 mm) .004" max (02-35)

(0.15 mm) .006" max (36-50)*

*(.004" stencil solution

may be available; contact

ipg@samtec.com)

02 thru 50

-F
= Gold flash on contact, Matte Tin on tail

-L
= 10 μ" (0.25 μm) Gold on contact, Matte Tin on tail

-G
= 10 μ" (0.25 μm) Gold (-D only)

-D
= Double Row

-DH
= Double Horizontal (Requires FTSH-04 lead style)

-BE
= Bottom Entry (Required for bottom entry applications)

-A
= Alignment Pin (Not available with -PA option) (05, 06, 07, 08, 10, 12, 15, 20, 25, 30, 40 positions only) (-DH option and other sizes. Contact Samtec.)

-K
= (4.00 mm) .157" DIA Polyimide film Pick & Place Pad

-P
= Pick & Place Pad (5 positions min. -D only) (Not always necessary for auto placement. See Flex Processing.)

-PA
= Pick & Place Pad with Alignment Pin (-D only) (Not available with -A option)

-TR
= Tape & Reel

-FR
= Full Reel Tape & Reel (must order maximum quantity per reel; contact Samtec for quantity breaks)

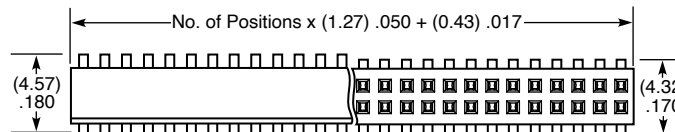

ALSO AVAILABLE

Contact Samtec

Single row

Other platings

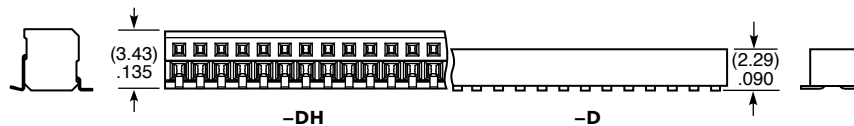

Notes:

Severe Environment Testing qualified; aligns with MIL-DTL-55302. Visit samtec.com/set

Some lengths, styles and options are non-standard, non-returnable.

PIN/ROW	A
04-15	(3.56) .140
16-50	(7.11) .280

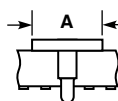

If odd pins/row, alignment pins are on middle position on centerline of the part. If even pins/row, then alignment pins are between middle two positions.

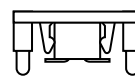

-PA OPTION



-P OPTION

COST-EFFECTIVE RELIABLE SOCKET

(1.27 mm) .050" PITCH • FLE SERIES

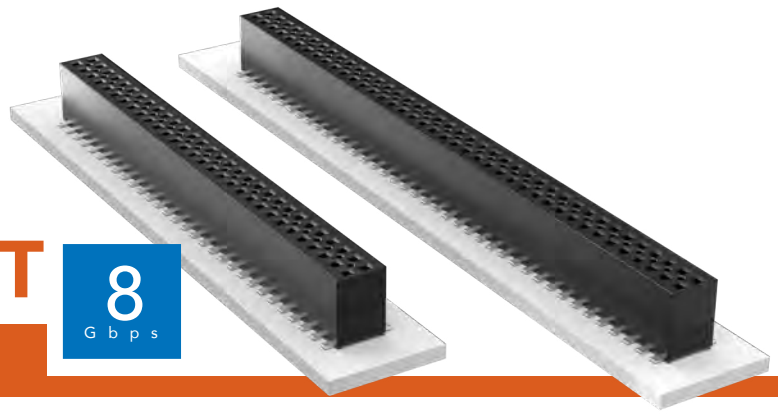

FLE

Board Mates:
FTSH, FTS, FW

Cable Mates:
FFMD*, FMTP

***Note:**
Standard FFMD callout will not mate with FLE, SFMC. Must use gold plated callouts. (See drawing on web.)



02 thru 50

-G
= 10 μ" (0.25 μm) Gold

-A
= Alignment Pin
(Metal or plastic at Samtec discretion)
(3 positions minimum)

-K
= (4.25 mm) .167" DIA
Polyimide film
Pick & Place Pad
(5 positions minimum)

-P
= Metal Pick & Place Pad
(5 positions minimum)

-TR
= Tape & Reel

-FR
= Full Reel Tape & Reel
(must order maximum quantity per reel; contact Samtec for quantity breaks)

SPECIFICATIONS

Insulator Material:
Black Liquid Crystal Polymer

Contact Material:
Phosphor Bronze

Plating:
Au over 50 μ" (1.27 μm) Ni

Operating Temp Range:
-55 °C to +125 °C

Current Rating:
2.9 A per pin
(2 pins powered)

Voltage Rating:
281 VAC/397 VDC

Insertion Depth:
(1.83 mm) .072" to (4.37 mm)
.172" or pass-through

Max Cycles:
100+

PROCESSING

Lead-Free Solderable:
Yes

SMT Lead Coplanarity:
(0.10 mm) .004" max

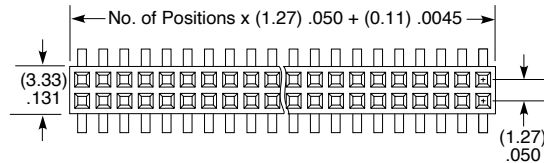

ALSO AVAILABLE

Contact Samtec

Other Plating

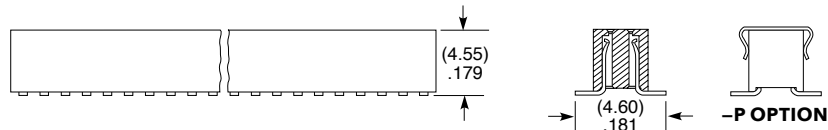

Note:

Some lengths, styles and options are non-standard, non-returnable.

THROUGH-HOLE MICRO HEADER

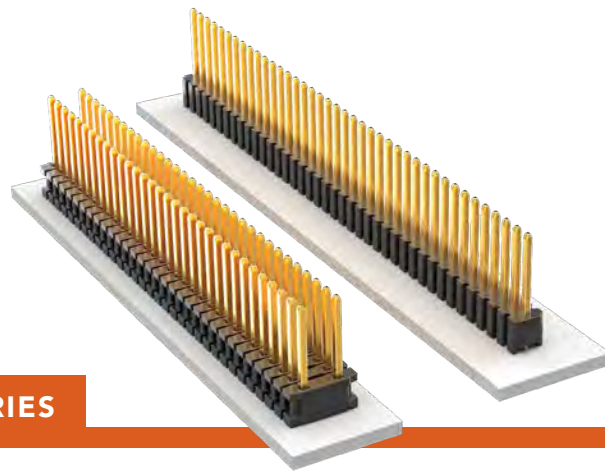

(1.27 mm) .050" PITCH • TMS/HTMS SERIES

TMS/HTMS

Mates:
SMS, SLM, RSM

SPECIFICATIONS

Insulator Material:
Black Liquid Crystal Polymer

Terminal Material:
Phosphor Bronze

Plating:

Au or Sn over
50 μ" (1.27 μm) Ni

Current Rating (TMS/SMS):

5 A per pin
(2 pins powered)

Voltage Rating:
300 VAC/424 VDC

Operating Temp Range:

-55 °C to +105 °C with Tin;
-55 °C to +125 °C with Gold

PROCESSING

Lead-Free Solderable:
Yes

SERIES	1	NO. PINS PER ROW	LEAD STYLE	PLATING OPTION	ROW OPTION	OPTION
--------	---	------------------	------------	----------------	------------	--------

TMS
= Standard

01 thru 50

Specify
**LEAD
STYLE**
from
chart

-F
= Gold flash
on contact,
Matte Tin on
tail

-L
= 10 μ"
(0.25 μm)
Gold on post,
Matte Tin
on tail

-G
= 10 μ"
(0.25 μm)
Gold on post,
Gold flash
on tail

-S
= Single
Row

-D
= Double
Row

-RA
= Right-
angle

-"XXX"
= Polarized
Position
(Specify position
of omitted pin)

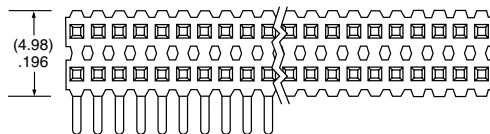
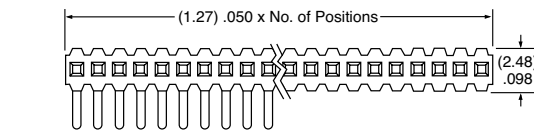

T/H LEAD STYLE	A	B	C
-01	(11.43) .450	(5.84) .230	(3.05) .120
-02	(8.13) .320	(2.54) .100	(3.05) .120
-21	(12.83) .505	(5.84) .230	(4.45) .175
-51	(10.41) .410	(4.83) .190	(3.05) .120
-52	(10.80) .425	(5.21) .205	(3.05) .120
-53	(12.83) .505	(7.24) .285	(3.05) .120
-54	(14.10) .555	(8.51) .335	(3.05) .120
-55	(15.49) .610	(9.91) .390	(3.05) .120
-56	(15.88) .625	(10.29) .405	(3.05) .120
-57	(16.51) .650	(10.92) .430	(3.05) .120
-58	(17.91) .705	(12.32) .485	(3.05) .120
-59	(19.18) .755	(13.59) .535	(3.05) .120
-60	(20.96) .825	(15.37) .605	(3.05) .120

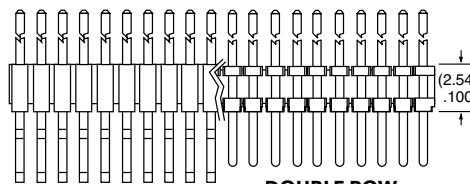

SINGLE ROW

DOUBLE ROW

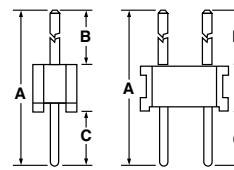

HTMS
-D
BODY
DESIGN

ALSO AVAILABLE
Contact Samtec

Other Plating

Important Note:

Style -02 does not mate
with SMS Series.

RA LEAD STYLE	D
-01	(5.84) .230
-02	(2.54) .100
-03	(3.18) .125

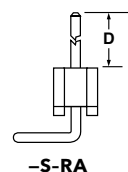

-S-RA

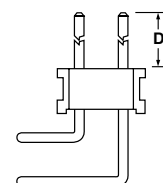

-D-RA

Note:

Some lengths, styles and
options are non-standard,
non-returnable.

SHROUDED HEADERS & STACKERS

(1.27 mm) .050" PITCH • TML/ZML SERIES



TML/ZML

Mates:
SMS, RSM

SPECIFICATIONS

TML

Insulator Material:
Black Liquid Crystal Polymer
Terminal Material:
Phosphor Bronze
Plating:
Au or Sn over
50 μ" (1.27 μm) Ni
Operating Temp Range:
-55 °C to +105 °C with Tin;
-55 °C to +125 °C with Gold

ZML

Insulator Material:
Black Liquid Crystal Polymer
Terminal Material:
Phosphor Bronze
Plating:
Au or Sn over
50 μ" (1.27 μm) Ni
Operating Temp Range:
-55 °C to +105 °C with Tin;
-55 °C to +125 °C with Gold

PROCESSING

TML

Lead-Free Solderable:
Yes
SMT Lead Coplanarity:
(0.10 mm) .004" max (05-20)
(0.15 mm) .006" max (32)*
*(.004" stencil solution
may be available; contact
ipg@samtec.com)

ZML

Same as TML except:
SMT Lead Coplanarity:
(0.15 mm) .006" max*
*(.004" stencil solution
may be available; contact
ipg@samtec.com)

ALSO AVAILABLE
Contact Samtec

Other sizes
Other platings

Notes:

For added mechanical stability, Samtec recommends mechanical board spacers be used in applications with gold or selective gold plated connectors. Contact ipg@samtec.com for more information.

Some sizes, styles and options are non-standard, non-returnable.

TML	1	NO. PINS PER ROW	LEAD STYLE	PLATING OPTION	D	TAIL OPTION	OTHER OPTION								
		05, 08, 10, 20, 32 (Standard sizes)	Specify LEAD STYLE from chart	-F = Gold flash on post, Matte Tin on tail -L = 10 μ" (0.25 μm) Gold on post, Matte Tin on tail -G = 10 μ" (0.25 μm) Gold on post, Gold flash on tail		(Leave blank for Through-hole) -RA = Right-angle -SM = Surface Mount (For locking clip add -LC)	-“XXX” = Polarized position (Specify position of omitted pin)								
						<table border="1"> <thead> <tr> <th>LEAD STYLE</th> <th>POST HEIGHT (A)</th> </tr> </thead> <tbody> <tr> <td>-01</td> <td>(3.05) .120</td> </tr> <tr> <td>-02</td> <td>(5.84) .230</td> </tr> <tr> <td>-03</td> <td>(4.32) .170</td> </tr> </tbody> </table>		LEAD STYLE	POST HEIGHT (A)	-01	(3.05) .120	-02	(5.84) .230	-03	(4.32) .170
LEAD STYLE	POST HEIGHT (A)														
-01	(3.05) .120														
-02	(5.84) .230														
-03	(4.32) .170														
						<table border="1"> <thead> <tr> <th>LEAD STYLE</th> <th>POST HEIGHT (A)</th> </tr> </thead> <tbody> <tr> <td>-01</td> <td>(3.05) .120</td> </tr> <tr> <td>-02</td> <td>(5.84) .230</td> </tr> <tr> <td>-03</td> <td>(4.32) .170</td> </tr> </tbody> </table>		LEAD STYLE	POST HEIGHT (A)	-01	(3.05) .120	-02	(5.84) .230	-03	(4.32) .170
LEAD STYLE	POST HEIGHT (A)														
-01	(3.05) .120														
-02	(5.84) .230														
-03	(4.32) .170														

ZML	1	NO. PINS PER ROW	LEAD STYLE	PLATING OPTION	D	BODY HEIGHT	TAIL OPTION											
		05, 08, 10, 20, 32 (Standard sizes)	Specify LEAD STYLE from chart	-L = 10 μ" (0.25 μm) Gold on post, Matte Tin on tail -G = 10 μ" (0.25 μm) Gold on post, Gold flash on tail		(Leave blank for Through-hole) -“XXX” = -SM Body Height (Specify board space “B” in inches from lead style charts.)	(Leave blank for Through-hole) -SM = Surface Mount											
						<table border="1"> <thead> <tr> <th>THROUGH-HOLE</th> <th>LEAD STYLE</th> <th>BODY HEIGHT (C)</th> </tr> </thead> <tbody> <tr> <td>-01</td> <td>(12.83) .505</td> </tr> <tr> <td>-02</td> <td>(14.22) .560</td> </tr> <tr> <td>-03</td> <td>(16.64) .655</td> </tr> <tr> <td>-04</td> <td>(19.69) .775</td> </tr> </tbody> </table>		THROUGH-HOLE	LEAD STYLE	BODY HEIGHT (C)	-01	(12.83) .505	-02	(14.22) .560	-03	(16.64) .655	-04	(19.69) .775
THROUGH-HOLE	LEAD STYLE	BODY HEIGHT (C)																
-01	(12.83) .505																	
-02	(14.22) .560																	
-03	(16.64) .655																	
-04	(19.69) .775																	
						<table border="1"> <thead> <tr> <th>SURFACE MOUNT</th> <th>LEAD STYLE</th> <th>POST HEIGHT (A)</th> <th>BODY HEIGHT (B)</th> </tr> </thead> <tbody> <tr> <td>-53</td> <td>(3.05) .120</td> <td>(13.46) .530 to (20.19) .795</td> </tr> <tr> <td>-54</td> <td>(5.84) .230</td> <td>(13.46) .530 to (17.40) .685</td> </tr> </tbody> </table>		SURFACE MOUNT	LEAD STYLE	POST HEIGHT (A)	BODY HEIGHT (B)	-53	(3.05) .120	(13.46) .530 to (20.19) .795	-54	(5.84) .230	(13.46) .530 to (17.40) .685	
SURFACE MOUNT	LEAD STYLE	POST HEIGHT (A)	BODY HEIGHT (B)															
-53	(3.05) .120	(13.46) .530 to (20.19) .795																
-54	(5.84) .230	(13.46) .530 to (17.40) .685																

MICRO BOARD STACKER

(1.27 mm) .050" PITCH • DWM/HDWM SERIES

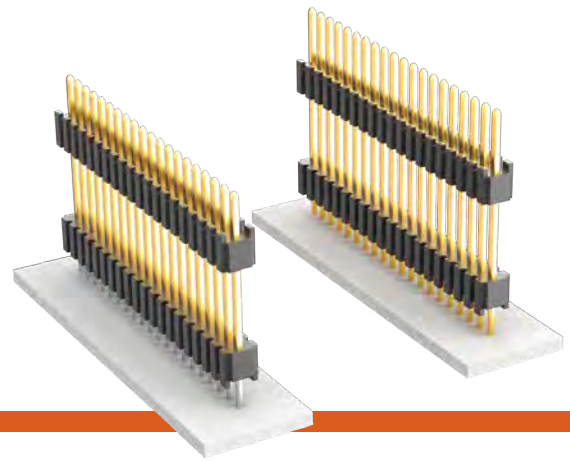

DWM/HDWM

Mates:
SMS, SLM, RSM

SPECIFICATIONS

Insulator Material:
Liquid Crystal Polymer
Terminal Material:
Phosphor Bronze
Plating:
Au or Sn over 50 μ" (1.27 μm) Ni
Operating Temp Range:
-55 °C to +105 °C with Tin
-55 °C to +125 °C with Gold

PROCESSING

Lead-Free Solderable:
Yes
SMT Lead Coplanarity:
(0.15 mm) .006" max*
*(.004" stencil solution may be available; contact ipg@samtec.com)

ALSO AVAILABLE

Contact Samtec

Other Platings

DWM	NO. PINS PER ROW	LEAD STYLE	PLATING OPTION	ROW OPTION	STACKER HEIGHT	OTHER OPTION
	01 thru 50	Specify LEAD STYLE from chart	-L = 10 μ" (0.25 μm) Gold on contact, Matte Tin on tail -G = 10 μ" (0.25 μm) Gold on contact, Gold flash on tail	-S = Single Row -D = Double Row	- "XXX" = Stacker Height Example: -200 = (5.08 mm) .200"	- "XXX" = Polarized Position (Specify position of omitted pin)

OAL	
LEAD STYLE	THROUGH-HOLE
-01	(11.43) .450
-51	(10.41) .410
-52	(10.80) .425
-53	(12.83) .505
-54	(14.10) .555
-55	(15.49) .610
-56	(15.88) .625
-57	(16.51) .650
-58	(17.91) .705
-59	(19.18) .755
-60	(20.96) .825
-61	(26.67) 1.050

HDWM	NO. PINS PER ROW	LEAD STYLE	PLATING OPTION	ROW OPTION	STACKER HEIGHT	OTHER OPTION
	01 thru 50	Specify LEAD STYLE from chart	-L = 10 μ" (0.25 μm) Gold on contact, Matte Tin on tail -G = 10 μ" (0.25 μm) Gold on contact, Gold flash on tail	-S = Single Row -D = Double Row	- "XXX" = Stacker Height Example: -250 = (6.35 mm) .250"	- "XXX" = Polarized Position (Specify position of omitted pin) - SM = Surface Mount (02 thru 40 positions only) - A = Alignment Pin (6 positions minimum -D only) Metal or plastic at Samtec discretion (Not available with -LC) - LC = Locking Clip (5 positions minimum -D only) (Not available with -A) (Manual placement required) - P = Pick & Place Pad

OAL		
LEAD STYLE	THROUGH-HOLE	SURFACE MOUNT
-01	(11.43) .450	(8.38) .330
-51	(10.41) .410	—
-52	(10.80) .425	—
-53	(12.83) .505	(9.78) .385
-54	(14.10) .555	(11.05) .435
-55	(15.49) .610	(12.45) .490
-56	(15.88) .625	(12.83) .505
-57	(16.51) .650	(13.46) .530
-58	(17.91) .705	(14.86) .585
-59	(19.18) .755	(15.62) .615
-60	(20.96) .825	—
-61	(26.67) 1.050	—

Notes:
For added mechanical stability, Samtec recommends mechanical board spacers be used in applications with gold or selective gold plated connectors. Contact ipg@samtec.com for more information.

This Series is non-standard, non-returnable.

SMT MICRO HEADER & SOCKET

(1.27 mm) .050" PITCH • FTR/RSM SERIES

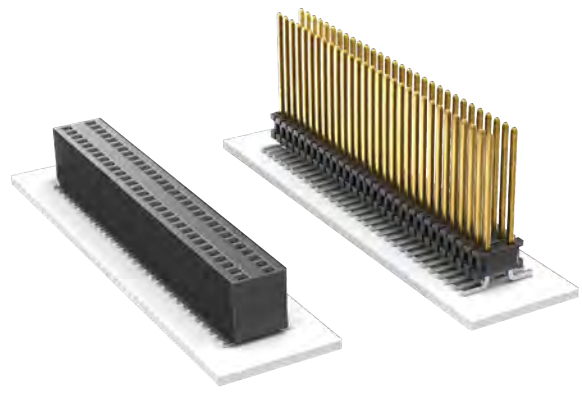

FTR
Mates:
RSM, SMS, SLM

RSM
Mates:
FTR, HTMS, HDWM,
DWM, TML, ZML, TMS

SPECIFICATIONS

Insulator Material:
Black Liquid Crystal Polymer
Contact Material:
RSM: Phosphor Bronze
Terminal Material:
FTR: Phosphor Bronze
Plating:
Au or Sn over
50 μm (1.27 μm) Ni
Operating Temp Range:
FTR: -55 °C to +105 °C with Tin;
FTR: -55 °C to +125 °C with Gold
RSM: -55 °C to +125 °C
Current Rating (FTR/RSM):
3.8 A per pin
(2 pins powered)
Voltage Rating:
290 VAC/410 VDC
Lead Size Accepted:
RSM: (0.46 mm) .018" SQ
Insertion Depth:
RSM: Top Entry =
(2.64 mm) .104" to (5.84 mm) .230"
with (0.38 mm) .015" wipe, or
pass-through.
RSM: Bottom Entry =
(5.49 mm) .216" minimum
(Add board thickness for
correct post OAL)

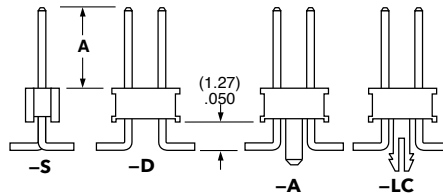
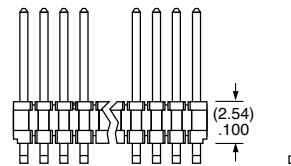
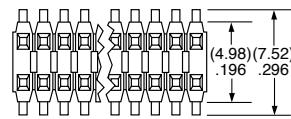
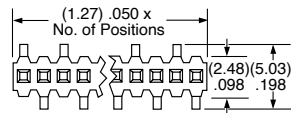

FTR	1	NO. PINS PER ROW	LEAD STYLE	PLATING OPTION	ROW OPTION	OPTION
------------	----------	-------------------------	-------------------	-----------------------	-------------------	---------------

02 thru 40

Specify
LEAD
STYLE
from
chart

-F
= Gold flash
on contact,
Matte Tin on tail

-L
= 10 μm (0.25 μm)
Gold on post,
Matte Tin on tail

-G
= 10 μm (0.25 μm)
Gold on post,
Gold flash on tail

-S
= Single Row

-D
= Double Row

LEAD STYLE	A
-01	(5.84) .230
-02	(2.54) .100
-03	(3.18) .125
-51	(4.83) .190
-52	(5.21) .205
-53	(7.24) .285
-54	(8.51) .335
-55	(9.91) .390
-56	(10.29) .405
-57	(10.92) .430

-XX
= Polarized

-A
= Alignment Pin
(5 positions min. for -D)
(Metal or plastic
at Samtec discretion)
(Not available with -LC)

-LC
= Locking Clip
(6 positions min. for -D)
(Not available with -A)
(Manual placement required)

-P
= Plastic Pick & Place Pad
(5 positions min. for -D)
(8 positions min. for -S)

-TR
= Tape & Reel
(4 positions min. for -S)

-FR
= Full Reel Tape & Reel
(must order max. quantity
per reel; contact Samtec
for quantity breaks)
(4 positions min. for -S)

PROCESSING

Lead-Free Solderable:
Yes
SMT Lead Coplanarity:
RSM: (0.10 mm) .004" max
FTR: (0.10 mm) .004" max (02-20)
FTR: (0.15 mm) .006" max (21-40)*
*(.004" stencil solution
may be available; contact
ipg@samtec.com)

RSM	1	NO. PINS PER ROW	02	PLATING OPTION	ROW OPTION	OPTION
------------	----------	-------------------------	-----------	-----------------------	-------------------	---------------

02 thru 36

-F
= Gold flash
on contact,
Matte Tin on tail

-L
= 10 μm (0.25 μm)
Gold on contact,
Matte Tin on tail

-S
= Single Row

-D
= Double Row

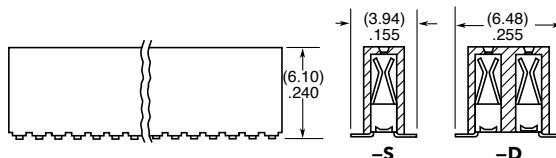
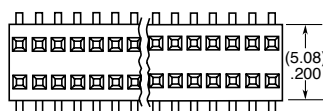
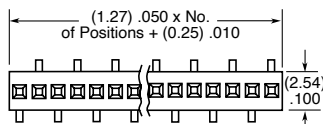

ALSO AVAILABLE
Contact Samtec

Other platings
Locking clips

-K
= (6.25 mm) .246" DIA
Polyimide film
Pick & Place Pad
(5 positions
minimum for -D)
(7 positions
minimum for -S)

-P
= Plastic Pick &
Place Pad
(5 positions
minimum for -D)
(6 positions
minimum for -S)

-TR
= Tape & Reel

-FR
= Full Reel Tape & Reel
(must order max.
quantity per reel;
contact Samtec for
quantity breaks)

Note:
Some lengths, styles and
options are non-standard,
non-returnable.

THROUGH-HOLE MICRO SOCKETS

(1.27 mm) .050" PITCH • SLM/SMS SERIES

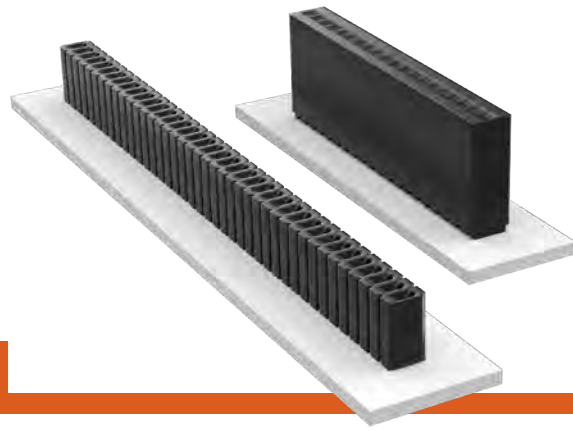

SLM

Mates:
HTMS, TMS, MTMS, DWM,
HDWM, FTR, HMTMS

SMS

Mates:
HTMS, TMS, MTMS,
DWM, HDWM, FTR, TML,
ZML, HMTM

SPECIFICATIONS

Insulator Material:
SLM: Black Glass Filled Polyester
SMS: Black LCP

Contact Material:
Phosphor Bronze

Plating:
Au or Sn over
50 μ" (1.27 μm) Ni

Operating Temp Range:
-55 °C to +125 °C with Gold
-55 °C to +105 °C with Tin

Current Rating (SLM/TMS):
5.2 A per pin
(2 pins powered)

Current Rating (SMS/TMS):
5.0 A per pin
(2 pins powered)

Voltage Rating:
SLM: 238 VAC/336 VDC
SMS: 300 VAC/424 VDC

Insertion Depth:
SLM: (2.03 mm) .080"
to (3.05 mm) .120"
SMS: (3.43 mm) .135" to
(6.35 mm) .250" with
(0.38 mm) .015" wiper

PROCESSING

Lead-Free Solderable:
SLM: No, Lead Wave Only
SMS: Yes

ALSO AVAILABLE

Contact Samtec

Other Platings

Note:
Some lengths, styles and
options are non-standard,
non-returnable.



01 thru 50

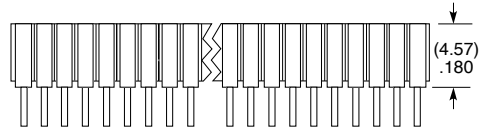
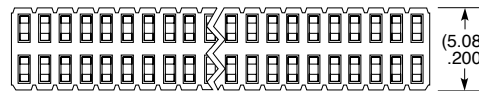
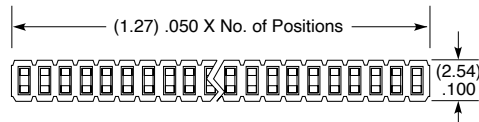

- F**
= Gold flash on contact,
Matte Tin on tail
- L**
= 10 μ" (0.25 μm) Gold on contact,
Matte Tin on tail
- G**
= 20 μ" (0.51 μm) Gold on contact,
Gold flash on balance
- S**
= Single Row
- D**
= Double Row

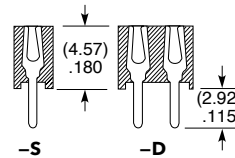

01 thru 50

Specify
LEAD
STYLE
from
chart

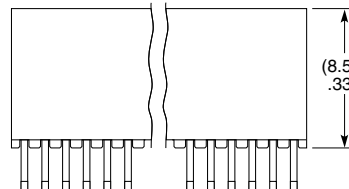
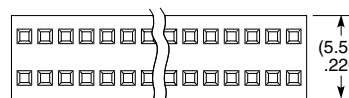
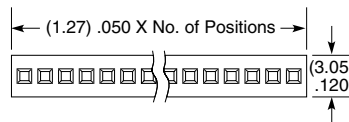

- F**
= Gold flash on contact,
Matte Tin on tail
- L**
= 10 μ" (0.25 μm) Gold on contact,
Matte Tin on tail
- G**
= 20 μ" (0.51 μm) Gold on contact,
Gold flash on balance
- S**
= Single Row
- D**
= Double Row

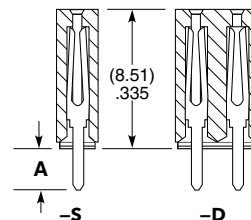

LEAD STYLE	A
-01	(2.54) .100
-02	(4.83) .190

LOW PROFILE SMT HEADER

(2.00 mm) .0787" PITCH • TMM SERIES

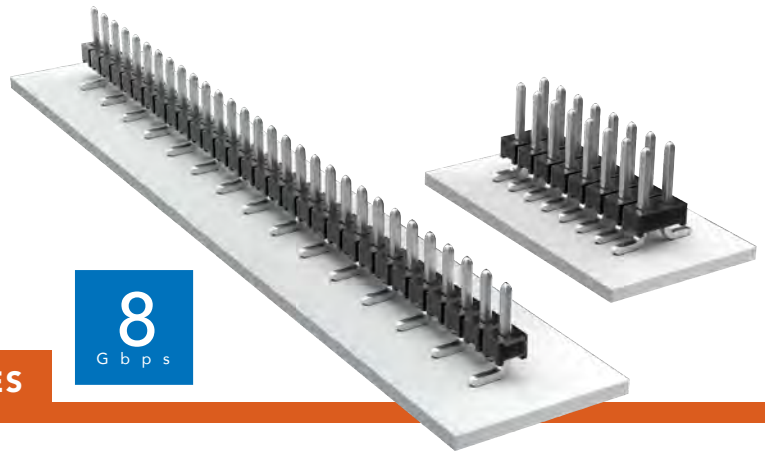

TMM

Board Mates:

CLT, SQT, SQW, ESQT, TLE, SMM, MMS

Cable Mates:

TCSD

SPECIFICATIONS

Insulator Material:

Black Liquid Crystal Polymer

Terminal Material:

Phosphor Bronze

Plating:

Sn or Au over
50 μ" (1.27 μm) Ni

Operating Temp Range:

-55 °C to +105 °C with Tin;
-55 °C to +125 °C with Gold

Current Rating:

3.3 A per pin
(2 pins powered)

Voltage Rating:

281 VAC/397 VDC
mated with SQW;
250 VAC/354 VDC
mated with SQT;
375 VAC/530 VDC
mated with SMM

PROCESSING

Lead-Free Solderable:

Yes

SMT Lead Coplanarity:

(0.15 mm) .006" max*
*(.004" stencil solution
may be available; contact
ipg@samtec.com)

TMM	- 1	NO. PINS PER ROW	LEAD STYLE	PLATING OPTION	ROW OPTION	SM	OTHER OPTION
-----	-----	------------------	------------	----------------	------------	----	--------------

02 thru 40

Specify
LEAD
STYLE
from
chart

-F
= Gold flash
on post,
Matte Tin on tail

-L
= 10 μ" (0.25 μm)
Gold on post,
Matte Tin on tail

-T
= Matte Tin

-S
= Single
Row

-D
= Double
Row

-A
= Alignment Pin
(Metal or plastic
at Samtec's
discretion)
(5 positions
minimum)
(-D only)

-"XXX"
= Polarized
Position
(Specify
position of
omitted pin)

-P
= Pick &
Place Pad
(3 positions
minimum)

-TR
= Tape & Reel
(3 thru 36
positions only)

-FR
= Full Reel
Tape & Reel
(must order max.
quantity per reel;
contact
Samtec for
quantity breaks)
(3 thru 36
positions only)

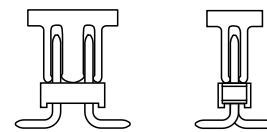
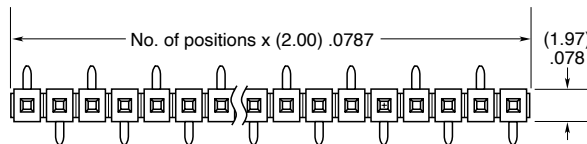

-P

ALSO AVAILABLE

Contact Samtec

Other plating

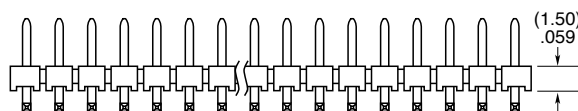
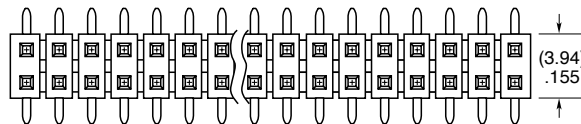

LEAD STYLE	A	MATES WITH
-01	(3.20) .126	SQT, SQW, ESQT, TLE, SMM, MMS, TCSD
-04	(1.91) .075	CLT
-05	(1.65) .065	
-06	(4.27) .168	CLT-BE

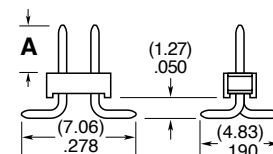

-D

-S



Note:

Some lengths, styles and options are non-standard, non-returnable.

THROUGH-HOLE LOW PROFILE HEADER

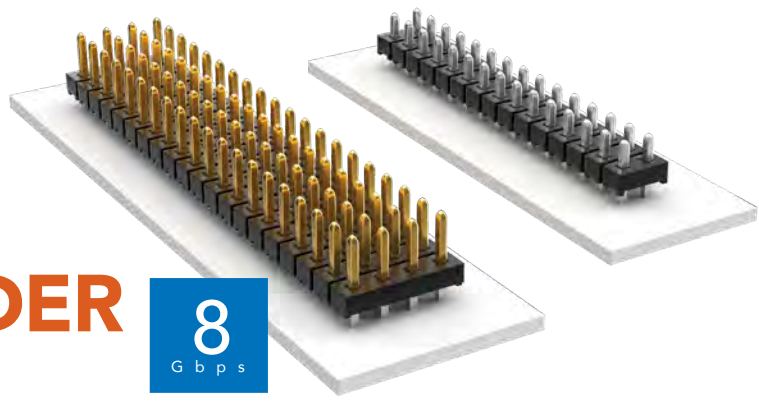

(2.00 mm) .0787" PITCH • TMM SERIES

TMM

Board Mates:
CLT, SQT, SQW, ESQT,
TLE, SMM, MMS

Cable Mates:
TCSD

TMM	- 1	NO. PINS PER ROW	- LEAD STYLE	- PLATING OPTION	- ROW OPTION	- OTHER OPTION
-----	-----	------------------	--------------	------------------	--------------	----------------

02 thru 50

Specify LEAD STYLE from chart

-F
= Gold flash on post, Matte Tin on tail

-L
= 10 μ" (0.25 μm) Gold on post, Matte Tin on tail

-T
= Matte Tin

-S
= Single Row

-D
= Double Row

-Q
= Four Row

-RA & -RE
= Right-angle (Lead Style -01 only) (2 positions minimum, -Q row)

-RC
= Retention Clip (Mates with TCSD) (Double row only, 4 positions minimum, only available -06 lead style)

-"XXX"
= Polarized Position (Specify position of omitted pin)

SPECIFICATIONS

Insulator Material:
Black Liquid Crystal Polymer

Terminal Material:
Phosphor Bronze

Plating:
Sn or Au over 50 μ" (1.27 μm) Ni

Operating Temp Range:
-55 °C to +105 °C with Tin;
-55 °C to +125 °C with Gold

Current Rating (SMM/TMM):
3.3 A per pin (2 pins powered)

Voltage Rating:
281 VAC/397 VDC mated with SQW;
250 VAC/354 VDC mated with SQT
375 VAC/530 VDC mated with SMM

PROCESSING

Lead-Free Solderable:
Yes

APPLICATION

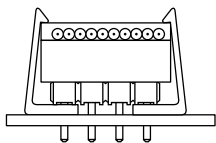

Retention Clip Option (-RC)

ALSO AVAILABLE
Contact Samtec

Other Platings



Note:
Some lengths, styles and options are non-standard, non-returnable.

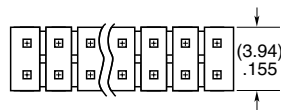
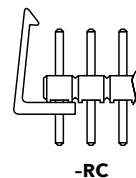
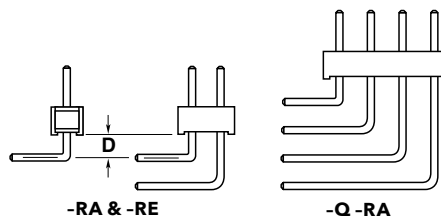
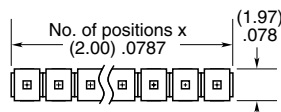

OPTION	D
-RA	(1.27) .050
-RE	(3.56) .140

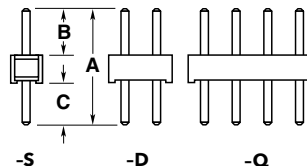
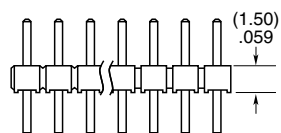
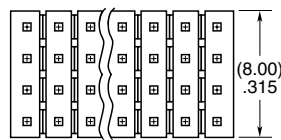

LEAD STYLE	A	B	C
-01		(3.20) .126	(3.50) .138
-02	(8.20) .323	(3.70) .146	(3.00) .118
-03		(4.00) .158	(2.70) .106
-04	(5.69) .224	(1.91) .075	(2.29) .090
-05	(5.43) .214	(1.65) .065	
-06	(9.58) .377	(3.20) .126	(4.88) .192

HORIZONTAL & MODIFIED HEADERS

(2.00 mm) .0787" PITCH • MMT/MTMM SERIES

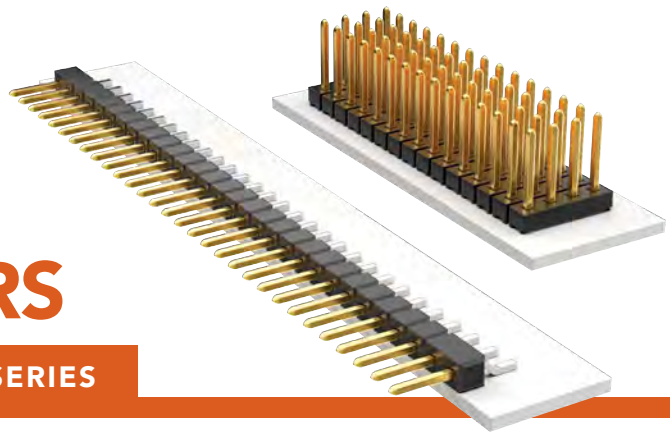

MMT/MTMM

Board Mates:

CLT, SQT*, SQW, ESQT, TLE, SMM, MMS

Cable Mates:

TCSD

*Important Note:

SQT will not mate to the MMT -02 lead style.

SPECIFICATIONS

Insulator Material:

Black Liquid Crystal Polymer

Terminal Material:

Phosphor Bronze

Plating:

Au or Sn over 50 μ" (1.27 μm) Ni

Operating Temp Range:

-55 °C to +105 °C with Tin;
-55 °C to +125 °C with Gold

PROCESSING

Lead-Free Solderable:

Yes

SMT Lead Coplanarity (MMT):

(0.10 mm) .004" max (02-25)
(0.15 mm) .006" max (26-36)*
*(.004" stencil solution may be available; contact ipg@samtec.com)

MMT	1	NO. PINS PER ROW	LEAD STYLE	PLATING OPTION	ROW OPTION	OPTION
		02 thru 36	-01 = (3.20 mm) .126" post -02 = (4.45 mm) .175" post	-F = Gold flash on post, Matte Tin on tail -L = 10 μ" (0.25 μm) Gold post, Matte Tin on tail -T = Matte Tin	-SH = Single Row -DH = Double Row -MT = Double Row Mixed Technology	-K = (4.00 mm) .157" DIA Polyimide Film Pick & Place Pad (3 positions min.) -P = Pick & Place Pad (2 positions min.) -"XXX" = Polarized Position Specify position of omitted pin -TR = Tape & Reel -FR = Full Reel Tape & Reel (must order max. quantity per reel; contact Samtec for quantity breaks)

ALSO AVAILABLE
Contact Samtec

Alignment pins
Locking clips
Molded pick & place pads

MTMM	1	NO. PINS PER ROW	LEAD STYLE	PLATING OPTION	ROW OPTION	POST HEIGHT	OPTION
		01 thru 50	Specify LEAD STYLE from chart	-F = Gold flash on post, Matte Tin on tail -L = 10 μ" (0.25 μm) Gold post, Matte Tin on tail -T = Matte Tin	-S = Single Row -D = Double Row -Q = Quad Row	-"XXX" = Post Height in inches (0.13 mm) .005" increments Example: -070 = (1.78 mm) .070"	-"XXX" = Polarized Position Specify position of omitted pin

LEAD STYLE	OAL
-02	(6.48) .255
-03	(7.67) .302
-04	(8.20) .323
-05	(9.58) .377
-06	(10.08) .397
-07	(11.58) .456
-08	(12.09) .476
-09	(13.59) .535
-10	(14.10) .555
-11	(15.09) .594
-12	(15.60) .614
-13	(17.09) .673
-14	(19.08) .751
-15	(21.08) .830

Note: Some lengths, styles and options are non-standard, non-returnable.

FLEXIBLE SMT HEADER

(2.00 mm) .0787" PITCH • TMMH SERIES

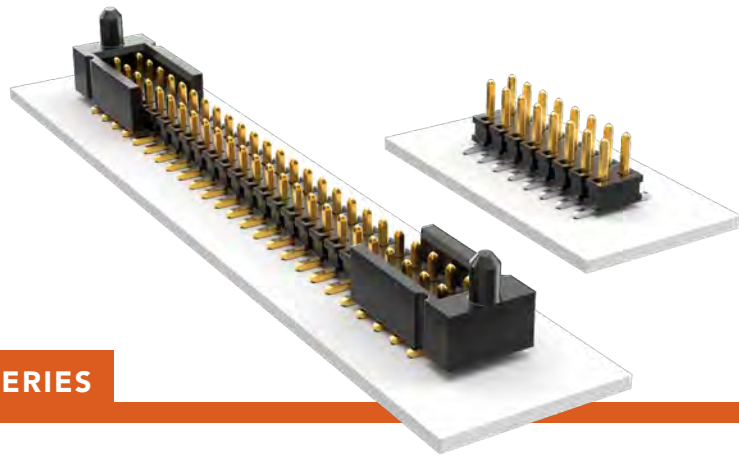

TMMH

Board Mates:

CLT, SQT, SQW, ESQT, TLE, SMM, MMS

Cable Mates:

TCSD

SPECIFICATIONS

Insulator Material:

Black Liquid Crystal Polymer

Terminal Material:

Phosphor Bronze

Plating:

Sn or Au over 50 μ" (1.27 μm) Ni

Operating Temp Range:

-55 °C to +105 °C with Tin;

-55 °C to +125 °C with Gold

Current Rating (TMMH/CLT):

4.2 A per pin

(2 pins powered)

Current Rating (TMMH/ESQT):

4.5 A per pin

(2 pins powered)

Current Rating (TMMH/SQT):

5.1 A per pin

(2 pins powered)

Voltage Rating:

405 VAC/573 VDC

mated with CLT;

281 VAC/397 VDC

mated with SQW;

250 VAC/354 VDC

mated with SQT

PROCESSING

Lead-Free Solderable:

Yes

SMT Lead Coplanarity:

(0.10 mm) .004" max

TMMH	1	NO. PINS PER ROW	LEAD STYLE	PLATING OPTION	DV	FLEX SHROUD OPTIONS	OTHER OPTIONS
------	---	------------------	------------	----------------	----	---------------------	---------------

03
thru
50

Specify
LEAD
STYLE
from
chart

-F
= Gold flash
on post,
Matte Tin
on tail

-L
= 10 μ"
(0.25 μm)
Gold on
post,
Matte Tin
on tail

-T
= Matte Tin

All Flex Shroud options
require 9 pins/row minimum
(For board-to-board
interfaces. Will not
mate with TCSD)

-ES
= End Shroud
(For best cost also
see TSH Series)

-EC
= End Shroud
with Locking Clip
(For best cost also
see TSH Series)
(Manual placement
required)

-EP
= End Shroud
with Guide Post

-EL
= End Shroud
with Board Lock
(Boards are positively
locked and cannot be
unmated)

-EBC
= End Shroud
with Board Lock
and Locking Clip
(Boards are positively
locked and cannot
be unmated)

-EPC
= End Shroud
with Guide Post
and Locking Clip
(Manual placement
required)

-"XXX"
= Polarized Position.
Specify position of
omitted pin

-A
= Alignment Pin
(3 positions minimum)
(Not available with -LC)

-LC
= Locking Clip
(5 positions minimum)
(Not available with -A)
(Manual placement
required)

-M
= Pick & Place Pad
(5 positions minimum)

-TR
= Tape & Reel Packaging
(36 positions maximum)
(Flex Shroud options
not available except
-ES, -EP & -EL)

-FR
= Full Reel
Tape & Reel
(must order max.
quantity per reel;
contact Samtec for
quantity breaks)
(36 positions maximum)
(Flex Shroud options
not available except
-ES, -EP & -EL)

OPTION	Z
-ES	(2.92) .115
-EC	(4.70) .185
-EP & -EPC	(6.10) .240
-EL & -EBC	(4.45) .175

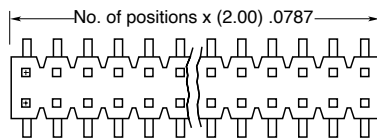
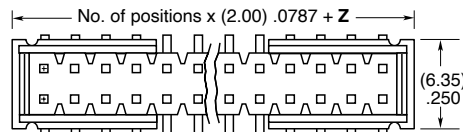

ALSO AVAILABLE

Contact Samtec

Other Platings

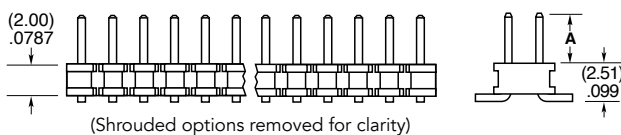

LEAD STYLE	A	MATES WITH
-01	(3.20) .126	SQT, SQW, ESQT, TLE, SMM, MMS, TCSD
-04	(1.91) .075	CLT
-05	(1.65) .065	

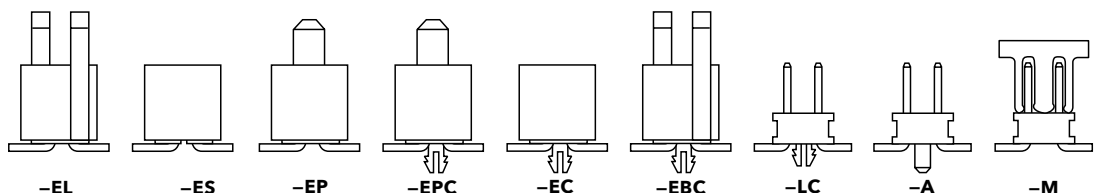

Note:
Some lengths, styles and
options are non-standard,
non-returnable.

FLEXIBLE THROUGH-HOLE HEADER

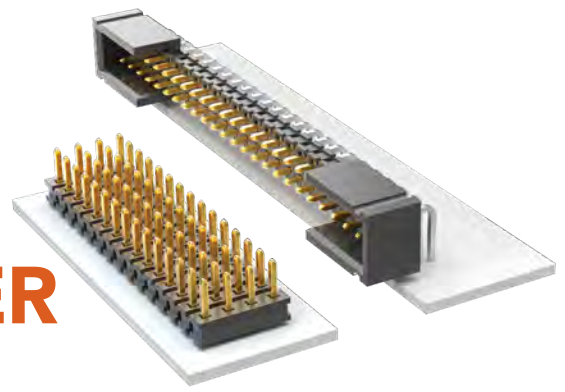

(2.00 mm) .0787" PITCH • TMMH SERIES

TMMH

Board Mates:

CLT, SQT, SQW, ESQT, TLE, SMM, MMS

Cable Mates:

TCSD

SPECIFICATIONS

Insulator Material:

Black Liquid Crystal Polymer

Terminal Material:

Phosphor Bronze

Plating:

Sn or Au over 50 μ" (1.27 μm) Ni

Operating Temp Range:

-55 °C to +105 °C with Tin;

-55 °C to +125 °C with Gold

Current Rating (TMMH/CLT):

4.2 A per pin

(2 pins powered)

Current Rating (TMMH/ESQT):

4.5 A per pin

(2 pins powered)

Current Rating (TMMH/SQT):

5.1 A per pin

(2 pins powered)

Voltage Rating:

405 VAC/573 VDC

mated with CLT;

281 VAC/397 VDC

mated with SQW;

250 VAC/354 VDC

mated with SQT

PROCESSING

Lead-Free Solderable:

Yes

APPLICATION

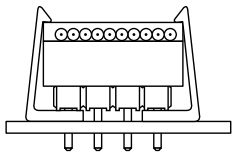

Retention Clip Option (-RC)

ALSO AVAILABLE

Contact Samtec

Other Platings



Note: Some lengths, styles and options are non-standard, non-returnable.

TMMH	1	NO. PINS PER ROW	LEAD STYLE	PLATING OPTION	ROW OPTION	TAIL OPTION	FLEX SHROUD OPTIONS	OTHER OPTIONS
------	---	------------------	------------	----------------	------------	-------------	---------------------	---------------

03
thru
50

Specify
LEAD
STYLE
from
chart

-F
= Gold flash
on post,
Matte Tin
on tail

-D
= Double
Row
(Required
for Flex
Shroud
option)

-RA
= Right-
angle
(Double
& Triple
Row only)
(-ES, -EP,
-EL Double
Row only)
(-EC, -EBC
and -EPC
not available)
(-06 Lead
style not
available)

Flex Shroud
requires -D row
& 9 pins/row
minimum
(For board-to-
board interfaces.
Will not mate
with TCSD)

-"XXX"
= Polarized
Position
(Specify
position of
omitted pin)

-RC
= Retention
Clip
(Mates to
TCSD)
(Double row
only, minimum
position 4 and
available only
-06 lead style)

OPTION	Z
-ES	(2.92) .115
-EC	(4.70) .185
-EP & -EPC	(6.10) .240
-EL & -EBC	(4.45) .175

-L
= 10 μ"
(0.25 μm)
Gold on
post,
Matte Tin
on tail

-T
= Triple
Row

-Q
= Four
Row

-T
= Matte
Tin

-5
= Five
Row

-6
= Six
Row

-ES
= End Shroud

-EC
= End Shroud
with Locking
Clip
(Manual
placement
required)

-EP
= End Shroud
with Guide Post

-EL
= End Shroud
with Board Lock
(Boards are
positively locked
and cannot be
unmated)

-EBC
= End Shroud
with Board Lock
and Locking Clip
(Boards are
positively locked
and cannot be
unmated)

-EPC
= End Shroud
with Guide Post
and Locking Clip
(Manual
placement
required)

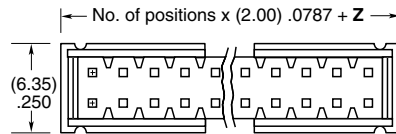

(Shrouded option requires -D)

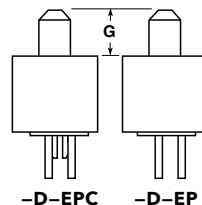
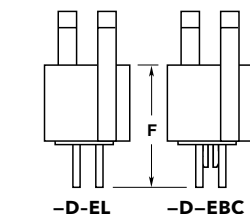
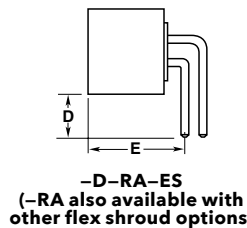
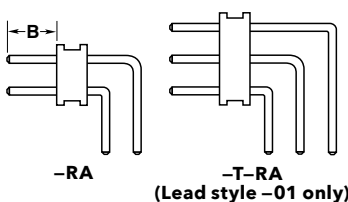
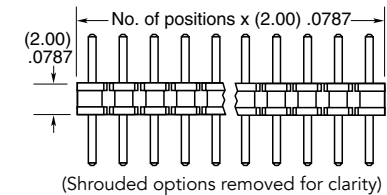
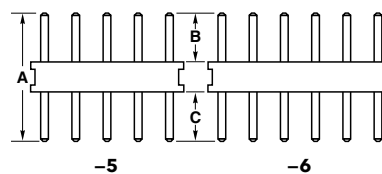
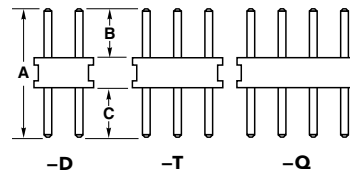
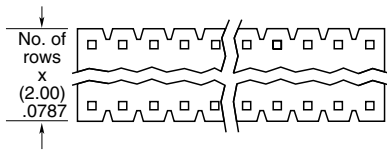

LEAD STYLE	A	B	C	D	E	F	G
-01	(7.67) .302	(3.20) .126	(2.46) .097	(2.34) .092	(6.60) .260	(5.84) .230	(4.45) .175
-04	(6.45) .254	(1.91) .075	(2.57) .101	(2.62) .103	(5.26) .207	(4.50) .177	(3.02) .119
-05	(6.45) .254	(1.65) .065	(2.29) .090	(3.12) .123	(5.26) .207		
-06	(8.74) .344	(3.20) .126	(3.53) .139	N/A	N/A	N/A	N/A

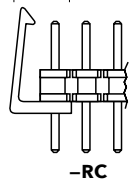
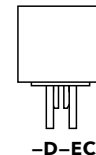
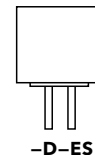

SHROUDED HEADER & STACKER

(2.00 mm) .0787" PITCH • LTMM/ZLTM SERIES

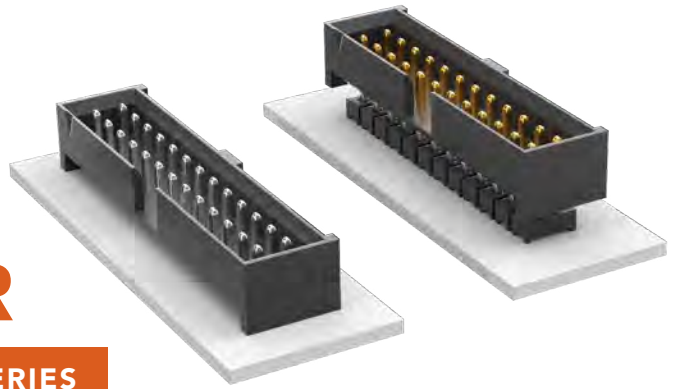

LTMM/ZLTM

Mates:
SQT, SQW, ESQT, SMM

SPECIFICATIONS

Insulator Material:
Black Liquid Crystal Polymer
Terminal Material:
Phosphor Bronze
Plating:
Sn or Au over
50 μ" (1.27 μm) Ni
Operating Temp Range:
-55 °C to +105 °C with Tin;
-55 °C to +125 °C with Gold

PROCESSING

Lead-Free Solderable:
Yes
SMT Lead Coplanarity:
(0.10 mm) .004" max

LTMM	1	NO. PINS PER ROW	02	PLATING OPTION	D	TAIL OPTION	OTHER OPTION
		04, 05, 06, 07, 08, 10, 12, 13, 15, 17, 20, 22, 25 (Standard sizes)		-F = Gold flash on post, Matte Tin on tail -L = 10 μ" (0.25 μm) Gold on post, Matte Tin on tail -T = Matte Tin		Leave blank for Through-hole -RA = Right-angle -SM = Surface Mount	-XX = Polarized Position -LC = Locking Clip (-SM only) (Manual placement required) -K = (7.50 mm) .295" DIA Film Pick & Place Pad (-SM only) -TR = Tape & Reel (-SM only) -FR = Full Reel Tape & Reel (must order max. quantity per reel; contact Samtec for quantity breaks) (-SM only)

ALSO AVAILABLE

Contact Samtec

Other sizes
Other plating

ZLTM	1	NO. PINS PER ROW	LEAD STYLE	PLATING OPTION	D	BODY HEIGHT	OTHER OPTION
		04, 05, 06, 07, 08, 10, 12, 13, 15, 17, 20, 22, 25 (Standard sizes)	Specify LEAD STYLE from chart	-F = Gold flash on post, Matte Tin on tail -L = 10 μ" (0.25 μm) Gold on post, Matte Tin on tail -T = Matte Tin		-XXX = Body Height	-XX = Polarized Position

LEAD STYLE	B (OAL)	MAX BODY HEIGHT
-75	(9.58) 0.377	(7.42) 0.292
-62	(10.08) 0.397	(7.92) 0.312
-65	(10.49) 0.413	(8.33) 0.328
-73	(12.09) 0.476	(9.93) 0.391
-63	(14.10) 0.555	(11.94) 0.470
-66	(15.09) 0.594	(12.93) 0.509
-69	(15.60) 0.614	(13.44) 0.529
-74	(17.09) 0.673	(14.94) 0.588
-70	(17.60) 0.693	(15.44) 0.608
-71	(21.08) 0.830	(18.92) 0.745
-72	(21.62) 0.851	(19.46) 0.766

Note:
This Series is non-standard, non-returnable.

Note:
For added mechanical stability, Samtec recommends mechanical board spacers be used in applications with gold or selective gold plated connectors. Contact ipg@samtec.com for more information.

SHROUDED HEADERS

(2.00 mm) .0787" PITCH • TSH/TMMS SERIES

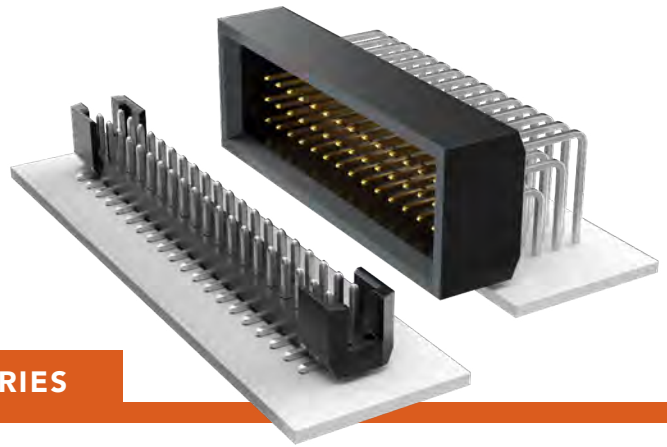

TSH

Mates:

CLT, SQT, SQW, ESQT,
TLE, SMM, MMS, PTF

TMMS

Mates:

SQT, SQW, ESQT

TSH	-	1	NO. PINS PER ROW	-	01	PLATING OPTION	-	ROW OPTION	-	OTHER OPTION
-----	---	---	------------------	---	----	----------------	---	------------	---	--------------

05, 10, 15, 20, 25,
30, 35, 40, 45
(40 & 45 = -D & -RA only)
(Standard sizes)

-F
= Gold flash on post, Matte Tin on tail

-D
= Vertical Through-hole

-LC
= Locking Clip (-DV only)
(Not available with -A)
(Manual placement required)

-L
= 10 μ" (0.25 μm) Gold on post, Matte Tin on tail

-DV
= Vertical Surface Mount

-A
= Alignment Pin (-DV only)
(Not available with -LC)

-RA
= Right-angle Through-hole

-SL
= Solder Locks (-DH only)

-T
= Matte Tin

-DH
= Horizontal Surface Mount

-K
= (4.50 mm) .177" DIA Polyimide Film Pick & Place Pad (-DH only)
(Not available with 15 - 30 positions)

-TR
= Tape & Reel

-FR
= Full Reel Tape & Reel (must order max. quantity per reel; contact Samtec for quantity breaks)

SPECIFICATIONS

Insulator Material:

Black Liquid Crystal Polymer

Terminal Material:

Phosphor Bronze

Plating:

Sn or Au over 50 μ" (1.27 μm) Ni

Operating Temp Range:

-55 °C to +105 °C with Tin;
-55 °C to +125 °C with Gold

PROCESSING

Lead-Free Solderable:

Yes

SMT Lead Coplanarity (TSH):

(0.15 mm) .006" max*
*(.004" stencil solution may be available; contact ipg@samtec.com)

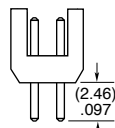
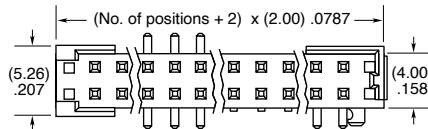

-D

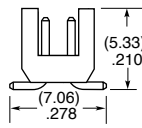

-DV

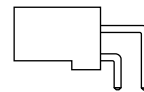

-RA

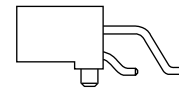

-DH

TMMS	-	1	NO. PINS PER ROW	-	01	PLATING OPTION	-	Q	OPTION	-	FS
------	---	---	------------------	---	----	----------------	---	---	--------	---	----

05, 10, 15,
20, 30, 40, 50

-F
= Gold flash on post, Matte Tin on tail

-RA
= Right-angle

-L
= 10 μ" (0.25 μm) Gold on post, Matte Tin on tail

ALSO AVAILABLE

Contact Samtec

Other sizes

Other plating

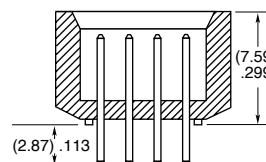
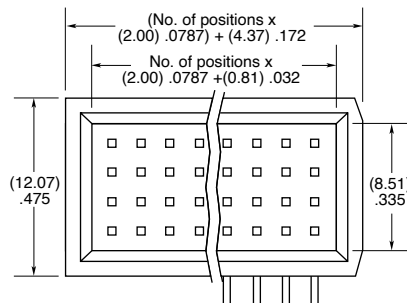

-RA

Note:

Some lengths, styles and options are non-standard, non-returnable.

SMT & THROUGH-HOLE BOARD STACKERS

(2.00 mm) .0787" PITCH • TW SERIES

CLT or MMS	SQT
8	4
G b p s	G b p s

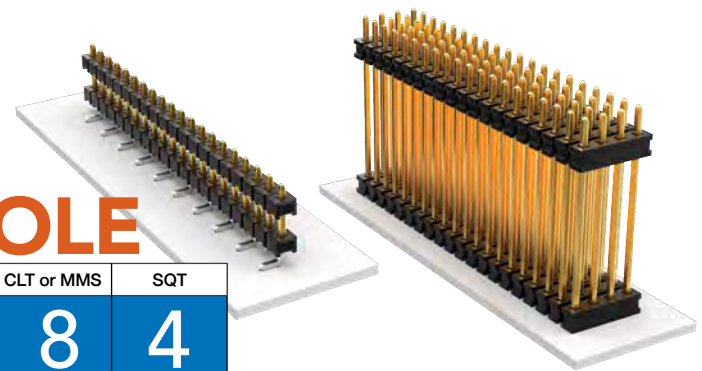

TW
Board Mates:
 CLT, SQT, SQW, ESQT,
 TLE, SMM, MMS

Cable Mates:
 TCS D

SPECIFICATIONS

Insulator Material:
 Black Liquid Crystal Polymer
Terminal Material:
 Phosphor Bronze
Plating:
 Sn or Au over
 50 μ" (1.27 μm) Ni
Operating Temp Range:
 -55 °C to +105 °C with Tin;
 -55 °C to +125 °C with Gold
Current Rating:
 3.9 A per pin
 (2 pins powered)
Voltage Rating:
 350 VAC/495 VDC

PROCESSING

Lead-Free Solderable:
 Yes
SMT Lead Coplanarity:
 (0.15 mm) .006" max*
 *(.004" stencil solution
 may be available; contact
 ipg@samtec.com)

ALSO AVAILABLE

Contact Samtec

Other Platings
 End shrouds with or
 without guide post

Notes:
 For added mechanical
 stability, Samtec recommends
 mechanical board spacers be
 used in applications with gold or
 selective gold plated connectors.
 Contact ipg@samtec.com for
 more information.

This Series is non-standard,
 non-returnable.

TW	NO. PINS PER ROW	LEAD STYLE	PLATING OPTION	ROW OPTION	STACKER HEIGHT	SM	OTHER OPTION																				
	02 thru 36	Specify LEAD STYLE from chart	-F = Gold flash on post, Matte Tin on tail -L = 10 μ" (0.25 μm) Gold on post, Matte Tin on tail -T = Matte Tin	-S = Single Row -D = Double Row	- "XXX" = Stacker Height in inches (0.13 mm) .005" increments Example: -250 = (6.35 mm) .250"		- "XXX" = Polarized Position -A = Alignment Pin (Metal or plastic at Samtec discretion) (4.83 mm) .190" min. board space (-D only) -P = Pick & Place Pad (1.91 mm) .075" min. post height (04-36 only) - "X"R = Specify "T" for Tape & Reel Specify "F" for Full Reel Tape & Reel (must order max. quantity per reel; contact Samtec for quantity breaks) (-07 lead style N/A) (-06 lead style with -P option N/A as standard)																				
				<table border="1"> <thead> <tr> <th>ROW OPTION</th> <th>A</th> </tr> </thead> <tbody> <tr> <td>-S</td> <td>(5.08) .200</td> </tr> <tr> <td>-D</td> <td>(6.35) .250</td> </tr> </tbody> </table>		ROW OPTION	A	-S	(5.08) .200	-D	(6.35) .250	<table border="1"> <thead> <tr> <th>LEAD STYLE</th> <th>OAL</th> </tr> </thead> <tbody> <tr> <td>-02</td> <td>(7.85) .309</td> </tr> <tr> <td>-03</td> <td>(11.86) .467</td> </tr> <tr> <td>-04</td> <td>(12.37) .487</td> </tr> <tr> <td>-06</td> <td>(15.37) .605</td> </tr> <tr> <td>-07</td> <td>(17.35) .683</td> </tr> <tr> <td>-09</td> <td>(9.86) .388</td> </tr> </tbody> </table>		LEAD STYLE	OAL	-02	(7.85) .309	-03	(11.86) .467	-04	(12.37) .487	-06	(15.37) .605	-07	(17.35) .683	-09	(9.86) .388
ROW OPTION	A																										
-S	(5.08) .200																										
-D	(6.35) .250																										
LEAD STYLE	OAL																										
-02	(7.85) .309																										
-03	(11.86) .467																										
-04	(12.37) .487																										
-06	(15.37) .605																										
-07	(17.35) .683																										
-09	(9.86) .388																										

TW	NO. PINS PER ROW	LEAD STYLE	PLATING OPTION	ROW OPTION	STACKER HEIGHT	TAIL SPEC																																
	02 thru 50	Specify LEAD STYLE from chart	-F = Gold flash on post, Matte Tin on tail -L = 10 μ" (0.25 μm) Gold on post, Matte Tin on tail -T = Matte Tin	-S = Single Row -D = Double Row -T = Triple Row -Q = Four Row -5 = Five Row -6 = Six Row	- "XXX" = Stacker Height in inches (0.13 mm) .005" increments Example: -250 = (6.35 mm) .250"	- "XXX" = Tail Length in inches (0.13 mm) .005" increments Example: -150 = (3.81 mm) .150" - "XXX" = Polarized Position (Specify position to be removed)																																
				<table border="1"> <thead> <tr> <th>ROW OPTION</th> <th>STACKER HEIGHT</th> </tr> </thead> <tbody> <tr> <td>-S, -D*, -Q</td> <td>(3.05) .120 MIN</td> </tr> <tr> <td>-T, -5, -6</td> <td>(4.06) .160 MIN</td> </tr> </tbody> </table>		ROW OPTION	STACKER HEIGHT	-S, -D*, -Q	(3.05) .120 MIN	-T, -5, -6	(4.06) .160 MIN	<table border="1"> <thead> <tr> <th>LEAD STYLE</th> <th>OAL</th> </tr> </thead> <tbody> <tr> <td>-01</td> <td>(8.20) .323</td> </tr> <tr> <td>-02</td> <td>(9.60) .377</td> </tr> <tr> <td>-03</td> <td>(13.60) .535</td> </tr> <tr> <td>-04</td> <td>(14.10) .555</td> </tr> <tr> <td>-05</td> <td>(15.10) .594</td> </tr> <tr> <td>-06</td> <td>(17.10) .673</td> </tr> <tr> <td>-07</td> <td>(19.10) .751</td> </tr> <tr> <td>-08*</td> <td>(21.10) .830</td> </tr> <tr> <td>-09</td> <td>(11.60) .456</td> </tr> <tr> <td>-10</td> <td>(15.60) .614</td> </tr> <tr> <td>-11</td> <td>(10.08) .397</td> </tr> <tr> <td>-12*</td> <td>(28.19) 1.110</td> </tr> </tbody> </table>	LEAD STYLE	OAL	-01	(8.20) .323	-02	(9.60) .377	-03	(13.60) .535	-04	(14.10) .555	-05	(15.10) .594	-06	(17.10) .673	-07	(19.10) .751	-08*	(21.10) .830	-09	(11.60) .456	-10	(15.60) .614	-11	(10.08) .397	-12*	(28.19) 1.110
ROW OPTION	STACKER HEIGHT																																					
-S, -D*, -Q	(3.05) .120 MIN																																					
-T, -5, -6	(4.06) .160 MIN																																					
LEAD STYLE	OAL																																					
-01	(8.20) .323																																					
-02	(9.60) .377																																					
-03	(13.60) .535																																					
-04	(14.10) .555																																					
-05	(15.10) .594																																					
-06	(17.10) .673																																					
-07	(19.10) .751																																					
-08*	(21.10) .830																																					
-09	(11.60) .456																																					
-10	(15.60) .614																																					
-11	(10.08) .397																																					
-12*	(28.19) 1.110																																					

PRESS-FIT HEADERS & SOCKETS

(2.00 mm) .0787" PITCH • PTT/PTF SERIES

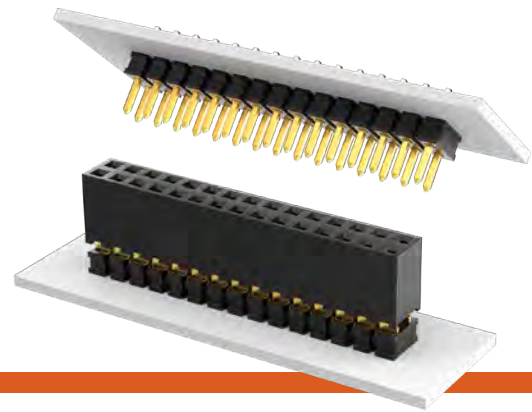

PTT
Mates:
PTF, ESQT, PTHF,
SQW, SQT, SMM

PTF
Mates:
PTT, TMMH, TMM, MTMM,
MMT, TW, LTMM, ZLTMM

SPECIFICATIONS

Insulator Material:
Black Liquid Crystal Polymer
Contact Material:
Phosphor Bronze
Plating:
Au or Sn over
50 μ " (1.27 μ m) Ni
Operating Temp Range:
-55 °C to +125 °C
Current Rating:
4.5 A per pin
(2 pins powered)
Voltage Rating:
250 VAC/354 VDC
Insertion Depth:
(2.67 mm) .105" to
(3.56 mm) .140"
Max Cycles:
100 with 30 μ " (0.76 μ m) Au



-L
= 10 μ " (0.25 μ m)
Gold contact,
Matte Tin on tail

-S
= Single Row
-D
= Double Row

-"XXX"
= Polarized
Position

ROW OPTION	A
-S	(2.00) .079
-D	(4.00) .158
-T	(6.00) .236
-Q	(8.00) .314
-5	(10.00) .393
-6	(12.00) .472

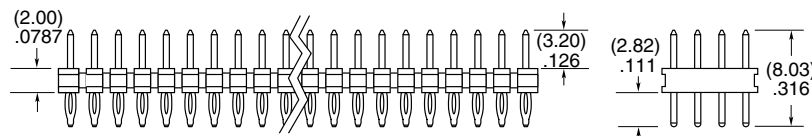
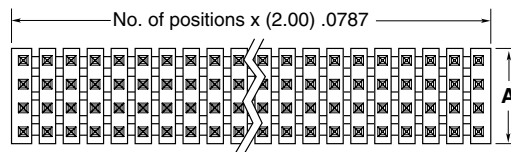

ALSO AVAILABLE

Contact Samtec

Other Platings



Specify
LEAD
STYLE
from
chart

-L
= 10 μ " (0.25 μ m)
Gold on post,
Matte Tin on tail

-"XXX"
= Polarized
Position

LEAD STYLE	A
-01	(6.35) .250
-03	(9.14) .360

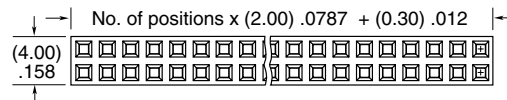

TOOLING

Press-Fit
PHT: CAT-PT-PH-1XX-X-X
PHF: CAT-PT-PH-1XX-X-B
For more information,
visit www.samtec.com/tooling

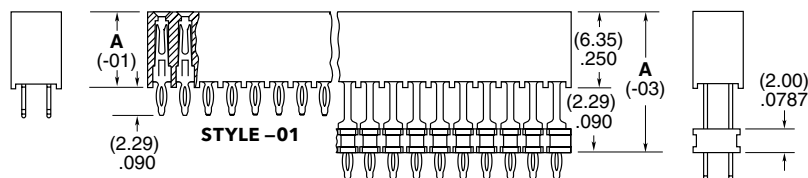

STYLE -01
STYLE -03

Note:
Some lengths, styles and
options are non-standard,
non-returnable.

FLEXIBLE ELEVATED & SELF-NESTING SOCKETS

(2.00 mm) .0787" PITCH • ESQT/ESQT (-368)/PTHF SERIES

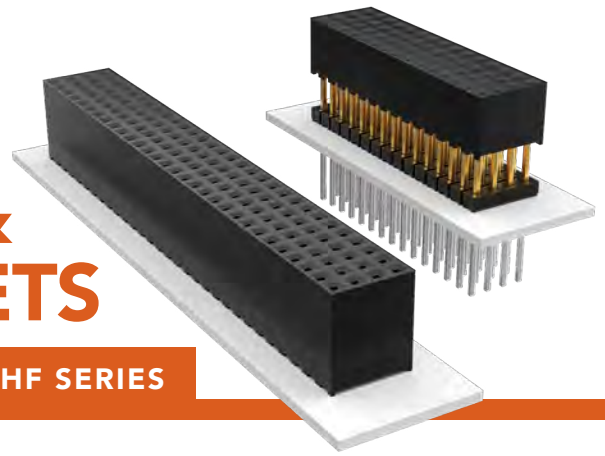

ESQT

Board Mates:
TMMH, TMM, MTMM, MMT, TW, LTMM, ZLTMM, ESQT, PTT, TSH, TMMS

Cable Mates:
TCMD

ESQT	1	NO. PINS PER ROW	LEAD STYLE	PLATING OPTION	ROW OPTION	BODY HEIGHT	OTHER OPTION
------	---	------------------	------------	----------------	------------	-------------	--------------

02 thru 50

Specify **LEAD STYLE** from chart

-F
= Gold flash on contact, Matte Tin on tail

-L
= 10 μ" (0.25 μm) Gold on contact, Matte Tin on tail

-M
= 20 μ" (0.51 μm) Gold on contact, Matte Tin on tail

-GF
= 15 μ" (0.38 μm) Gold on contact, Gold flash on tail (Recommended for self-nesting) (-02 lead style only)

-S
= Single Row

-D
= Double Row

-T
= Triple Row

-Q
= Quad Row

-5
= Five Row

-6
= Six Row

"XXX"
= Body Height (in inches)

(7.87 mm) .310" minimum for -S, -D, -Q

(9.53 mm) .375" minimum for -T, -5, -6

"XXX"
= Polarized Position (Indicate position number)

SPECIFICATIONS

Insulator Material:
Black Liquid Crystal Polymer
Contact Material:
Phosphor Bronze
Plating:
Sn or Au over 50 μ" (1.27 μm) Ni
Operating Temp Range:
-55 °C to +125 °C
Current Rating (ESQT/TMMH):
4.5 A per pin (2 pins powered)
Insertion Depth:
(2.62 mm) .103" to (5.03 mm) .198" with (0.38 mm) .015" wipe
Max Cycles:
100 with 10 μ" (0.25 μm) Au
Lead-Free Solderable:
Yes, for -S, -D & -Q (Wave only for -T, -5 & -6)

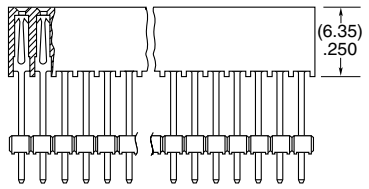
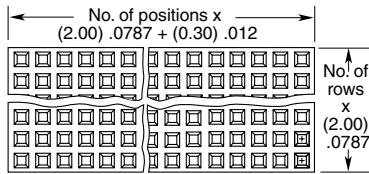

LEAD STYLE	A	MAX TAIL	MAX BODY HEIGHT
-02	(21.59) .850	(13.72) .540	(20.32) .800
-03	(11.63) .458	(3.76) .148	(10.36) .408

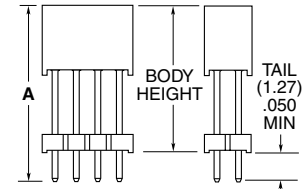

ESQT (-368)/PTHF

Mates:
ESQT, PTHF

SERIES	1	NO. PINS PER ROW	LEAD STYLE	PLATING OPTION	Q	368
--------	---	------------------	------------	----------------	---	-----

SPECIFICATIONS

Insulator Material:
Black Liquid Crystal Polymer (ESQT-368)
Black High Temp Nylon (PTHF)
Contact Material:
Phosphor Bronze
Plating:
Au or Sn over 50 μ" (1.27 μm) Ni
Operating Temp Range:
-55 °C to +125 °C
Max Cycles:
100 with 10 μ" (0.25 μm) Au
Lead-Free Solderable:
Yes (ESQT-368)

ESQT
= Solder Tails
PTHF
= Press-fit Tails

Specify **LEAD STYLE** from chart

-GF
= 15 μ" (0.38 μm) Gold on contact, Gold flash on tail (-02 Lead Style only)

-M
= 20 μ" (0.51 μm) Gold on contact, Matte Tin on tail (-03 Lead Style only)

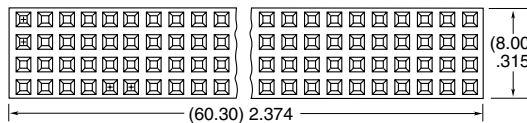
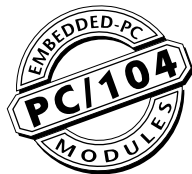

LEAD STYLE	ESQT		PTHF	
	A	B	A	B
-02	(21.59) .850	(12.24) .482	(21.59) .850	(12.24) .482
-03	(11.63) .458	(2.29) .090	(12.34) .486	(3.00) .118

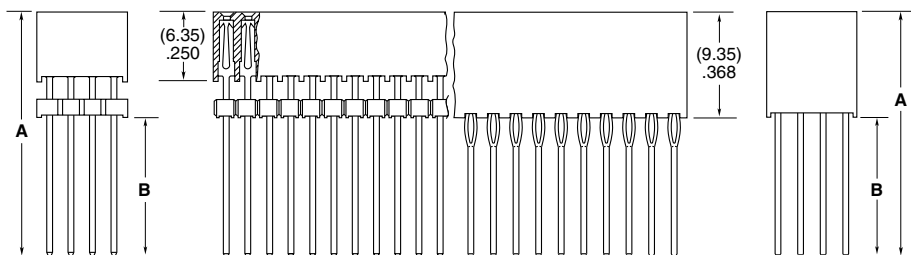

ESQT (-368) SERIES

PTHF SERIES

TOOLING

Press-Fit
CAT-PT-130-A-4
For more information, visit www.samtec.com/tooling

Note:
This Series is non-standard, non-returnable.

COST-EFFECTIVE RUGGED SOCKETS

(2.00 mm) .0787" PITCH • SQW/SQT SERIES

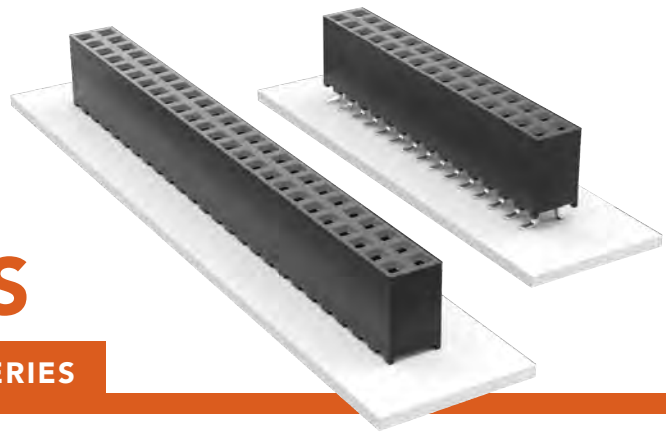

SQW/SQT

Board Mates:

TMMH, TMMs, TMM, MTMM, MMT, TW, TSH, LTMM, ZLTMM, PTT

Cable Mates:

TCMD

SPECIFICATIONS

Insulator Material:

Black Liquid Crystal Polymer

Contact Material:

Phosphor Bronze

Plating:

Sn or Au over
50 μ" (1.27 μm) Ni

Operating Temp Range:

-55 °C to +125 °C

Current Rating:

(SQW/TMMH) = 3.8 A per pin

(2 pins powered)

(TMMH/SQT) = 5.1 A per pin

(2 pins powered)

Voltage Rating:

281 VAC/398 VDC

mated with TMM;

250 VAC/354 VDC

mated with TMMH

SQW Insertion Depth:

(2.62 mm) .103" to

(5.03 mm) .198" with

(0.38 mm) .015" wipe

SQT Insertion Depth:

(2.62 mm) .103" to

(5.03 mm) .198"

Max Cycles:

100 with 10 μ" (0.25 μm) Au

SQW	1	NO. PINS PER ROW	01	PLATING OPTION	ROW OPTION	OPTION
------------	----------	-------------------------	-----------	-----------------------	-------------------	---------------

02 thru 50

-F

= Gold flash on contact, Matte Tin on tail

-L

= 10 μ" (0.25 μm) Gold on contact, Matte Tin on tail

-D

= Double Row

-D-VS

= Double Row Surface Mount

-T

= Triple Row

-Q

= Four Row

-5

= Five Row

-6

= Six Row

-“XXX”

= Polarized Position
-D-VS only options:

-A

= Alignment Pin (5 positions minimum)
Metal or plastic at Samtec discretion. (Not available with -LC)

-LC

= Locking Clip (5 positions minimum)
(Manual placement required)

-K

= (4.25 mm) .167" DIA Polyimide Film Pick & Place Pad (4 positions minimum)

-P

= Pick & Place Pad (4 positions minimum)

-TR

= Tape & Reel (4-28 positions only)

-FR

= Full Reel Tape & Reel (must order max. quantity per reel; contact Samtec for quantity breaks) (4-28 positions only)

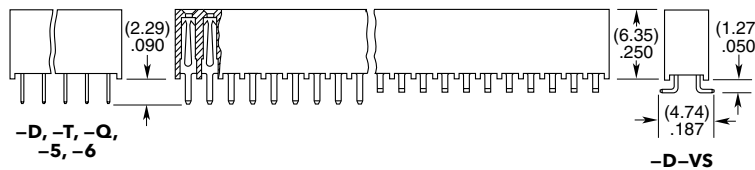

PROCESSING

SQW Lead-Free Solderable:

Yes, for -D & -D-VS

(Wave only for -T, -Q, -5 & -6)

SQT Lead-Free Solderable:

Yes

SMT Lead Coplanarity:

(0.10 mm) .004" max (02-10)

(0.15 mm) .006" max (11-50)*

*(.004" stencil solution may be available; contact ipg@samtec.com)

SQT	1	NO. PINS PER ROW	LEAD STYLE	PLATING OPTION	ROW OPTION	OTHER OPTION
------------	----------	-------------------------	-------------------	-----------------------	-------------------	---------------------

02 thru 50

Specify LEAD STYLE from chart

-F

= Gold flash on contact, Matte Tin on tail

-L

= 10 μ" (0.25 μm) Gold on contact, Matte Tin on tail

-S

= Single Row

-D

= Double Row

-T

= Triple Row

-Q

= Four Row

-5

= Five Row

-6

= Six Row

-RA

= Right-angle (-Q, -5 & -6 Row not available) (Lead Style -01 only)

-“XXX”

= Polarized Position (Indicate position number)

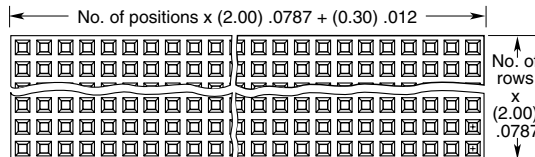

LEAD STYLE	A
-01	(2.29) .090
-02	(15.24) .600
-03	(5.28) .208

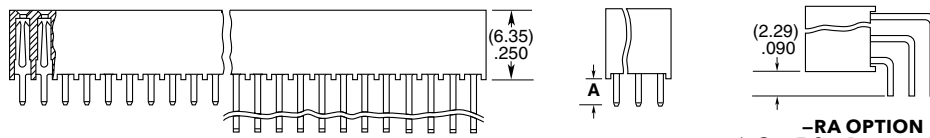

Note:

Some lengths, styles and options are non-standard, non-returnable.

TIGER CLAW™ SOCKET STRIP

(2.00 mm) .0787" PITCH • MMS SERIES

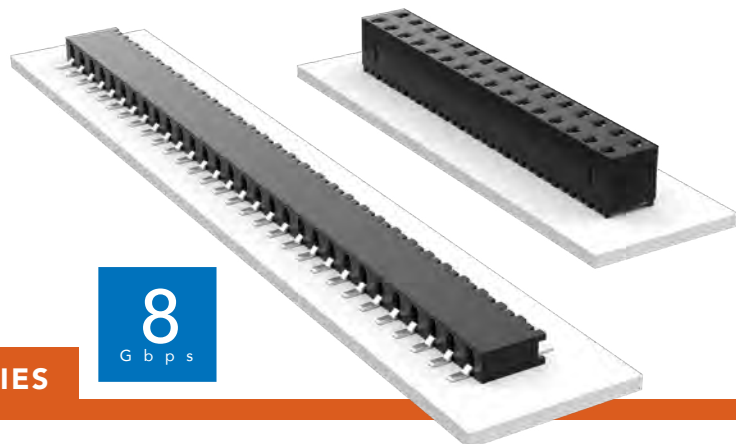

MMS

Board Mates:
TMMH, TMM, MTMM, MMT,
TW, LTMM, ZLTMM, TSH

Cable Mates:
TCMD

SPECIFICATIONS

Insulator Material:

Black LCP

Contact Material:

Phosphor Bronze

Plating:

Sn or Au over

50 μ" (1.27 μm) Ni

Operating Temp Range:

-55 °C to +125 °C with Gold

-55 °C to +105 °C with Tin

Current Rating (MMS/TMM):

3.9 A per pin

(2 pins powered)

Voltage Rating:

350 VAC/495 VDC

Insertion Depth:

DH = (2.13 mm) .084" to

(2.79 mm) .110"

SH = (2.13 mm) .084" minimum or pass-through

Top Entry DV/SV =

(2.13 mm) .084" to

(4.32 mm) .170"

Bottom Entry DV/SV =

(4.27 mm) .168" minimum

(Plus board)

MMS	- 1	NO. PINS PER ROW	- 01	PLATING OPTION	- ROW OPTION	OPTION
-----	-----	------------------	------	----------------	--------------	--------

02 thru 40

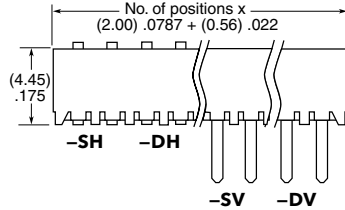
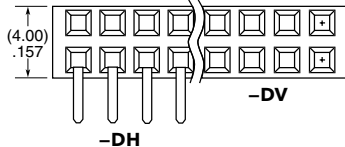

-F
= Gold flash on contact,
Matte Tin on tail

-L
= 10 μ" (0.25 μm)
Gold contact,
Matte Tin on tail

-SV
= Single
Vertical

-SH
= Single
Horizontal

-DV
= Double
Vertical

-DH
= Double
Horizontal

-"XX"
= Polarized
Position

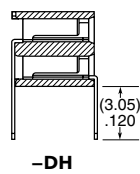
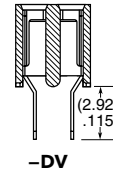
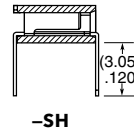
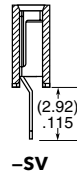

PROCESSING

Lead-Free Solderable:

Yes

SMT Lead Coplanarity:

(0.15 mm) .006" max*

*(.004" stencil solution

may be available; contact

ipg@samtec.com)

ALSO AVAILABLE

Contact Samtec

Alignment Pin (-DV only)

Locking clips and Through-hole
pass-through options

Other platings

MMS	- 1	NO. PINS PER ROW	- 02	PLATING OPTION	- ROW OPTION	OTHER OPTION
-----	-----	------------------	------	----------------	--------------	--------------

02 thru 40

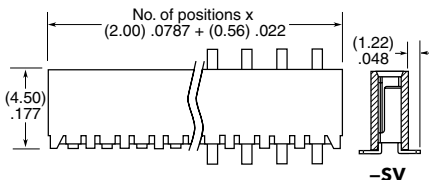
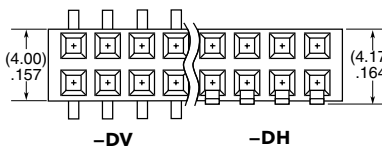
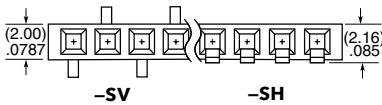

-F
= Gold flash
on contact,
Matte Tin on tail

-L
= 10 μ" (0.25 μm)
Gold contact,
Matte Tin on tail

-SV
= Single
Vertical

-SH
= Single
Horizontal

-DV
= Double
Vertical

-DH
= Double
Horizontal

-"XX"
= Polarized Position

-K
= (5.50 mm) .217" DIA
Polyimide Film
Pick & Place Pad
(3 positions min.)
(-SV & -DV only)

-M
= Metal Pick & Place Pad
(4 positions min.)
(-DV only)

-P
= Plastic Pick & Place Pad
(4 positions min.)
(-SV & -DV only)

-TR
= Tape & Reel

-FR
= Full Reel
Tape & Reel
(must order max.
quantity per reel;
contact Samtec for
quantity breaks)

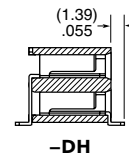
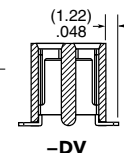
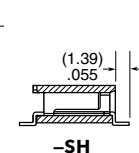
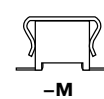
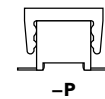

COST-EFFECTIVE & DUAL WIPE SOCKETS

(2.00 mm) .0787" PITCH • TLE/CLT SERIES

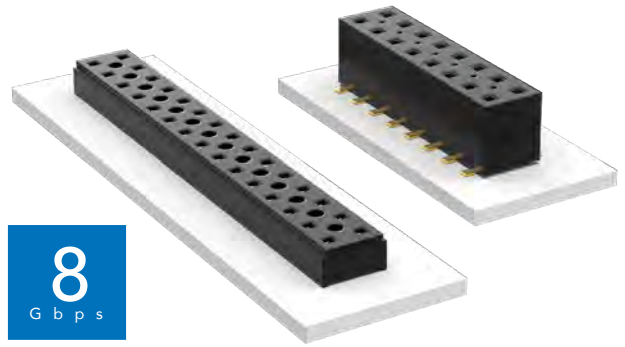

TLE

Mates:
TMMH, TMM, MTMM,
MMT, TW, LTMM, ZLTMM,
TCMD, TSH

CLT

Mates:
TMM, TMMH, MTMM,
MMT, TW, TSH

SPECIFICATIONS

TLE

Insulator Material:
Black Liquid Crystal Polymer
Contact Material:
Phosphor Bronze
Plating:
Au over 50 μ" (1.27 μm) Ni
Operating Temp Range:
-55 °C to +125 °C
Current Rating (TLE/TMMH):
3.2 A per pin (2 pins powered)
Voltage Rating:
406 VAC/574 VDC
Insertion Depth:
(2.08 mm) .082" to
(4.37 mm) .172" with
(0.38 mm) .015" wipe,
pass-through, or
(3.35 mm) .132" min
for bottom entry

CLT

Same as TLE except:
Plating:
Sn or Au over 50 μ" (1.27 μm) Ni
Current Rating (CLT/TMMH):
4.2 A per pin (2 pins powered)
Voltage Rating:
405 VAC/573 VDC
Insertion Depth:
Top Entry=
(1.40 mm) .055" minimum
Bottom Entry=
(2.57 mm) .101" minimum
(add board thickness for
correct post OAL)
Max Cycles:
100 with 10 μ" (0.25 μm) Au

PROCESSING

TLE

Lead-Free Solderable: Yes
SMT Lead Coplanarity:
(0.10 mm) .004" max (02-26)
(0.15 mm) .006" max (27-50)*
*(.004" stencil solution
may be available; contact
ipg@samtec.com)

CLT

Same as TLE except:
SMT Lead Coplanarity:
(0.10 mm) .004" max (02-25)
(0.15 mm) .006" max (26-34)*
(0.20 mm) .008" max (35-50)*
*(.004" stencil solution
may be available; contact
ipg@samtec.com)

Note:

Some lengths, styles and
options are non-standard,
non-returnable.

TLE	1	NO. PINS PER ROW	01	PLATING OPTION	DV	OPTIONS
		02 thru 50		-G = 10 μ" (0.25 μm) Gold		-A = Alignment Pin (3 positions minimum) -K = (5.00 mm) .197" DIA Polyimide Film Pick & Place Pad (3 positions minimum) -P = Metal Pick & Place Pad (4 positions minimum) -TR = Tape & Reel Packaging (2-37 positions only) -FR = Full Reel Tape & Reel (must order maximum quantity per reel; contact Samtec for quantity breaks) (2-37 positions only)

CLT	1	NO. PINS PER ROW	LEAD STYLE	PLATING OPTION	D	OTHER OPTIONS
		02 thru 50	-01 = Through-hole -02 = Surface Mount -03 = Through-hole	-F = Gold flash on contact, Matte Tin on tail -L = 10 μ" (0.25 μm) Gold on contact, Matte Tin on tail -G = 10 μ" (0.25 μm) Gold on contact, Gold flash on tail		All options require Style -02 -BE = Bottom Entry (Required for bottom entry applications) -A = Alignment Pin (3 positions minimum) Metal or plastic at Samtec's discretion -K = (5.00 mm) .197" DIA Polyimide Film Pick & Place Pad (04 thru 50 only) -P = Pick & Place Pad (4 positions minimum) (Not always necessary for auto placement.) -TR = Tape & Reel (36 positions max) -FR = Full Reel Tape & Reel (must order maximum quantity per reel; contact Samtec for quantity breaks) (36 positions max)

LEAD STYLE	A
-01	(2.16) .085
-03	(2.95) .116

SELF MATING HERMAPHRODITIC STRIP

(2.00 mm) .0787" PITCH • LS2 SERIES

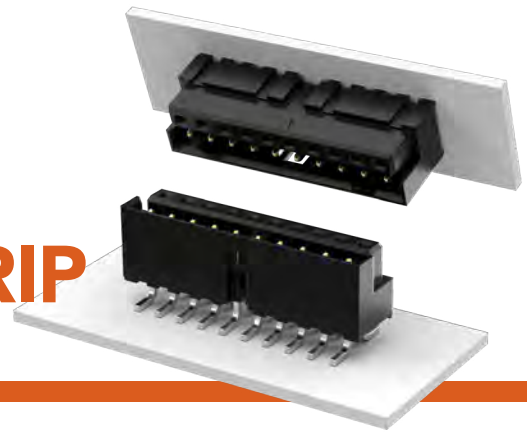

LS2
Mates:
LS2

SPECIFICATIONS

Insulator Material:
Black Liquid Crystal
Polymer
Contact Material:
Phosphor Bronze
Plating:
Au or Sn over
50 μ" (1.27 μm) Ni
Operating Temp Range:
-55 °C to +125 °C
Current Rating:
3.2 A per pin
(6 adjacent pins powered)
Voltage Rating:
475 VAC/672 VDC

PROCESSING

Lead-Free Solderable:
Yes
SMT Lead Coplanarity:
(0.15 mm) .006" max*
*(.004" stencil solution
may be available; contact
ipg@samtec.com)

LS2	1	NO. PINS PER ROW	LEAD STYLE	PLATING OPTION	D	TAIL OPTION	OPTION
-----	---	------------------	------------	----------------	---	-------------	--------

05, 10, 15,
20, 25, 30

-01
= Through-hole

-02
= Surface Mount

-F
= Gold flash on contact,
Matte Tin on tail

-L
= 10 μ" (0.25 μm)
Gold on contact,
Matte Tin on tail

-01 only

-RA1
= Right-angle
(Shroud Down)

-RA2
= Right-angle
(Shroud Up)

-K
= (6.30 mm)
.248" DIA
Polyimide
Film Pick &
Place Pad
(-02 only)

-TR
= Tape &
Reel

-FR
= Full Reel
Tape & Reel
(must order
max. quantity
per reel;
contact
Samtec for
quantity
breaks)

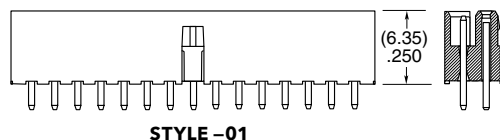
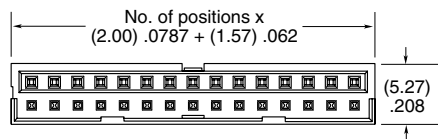
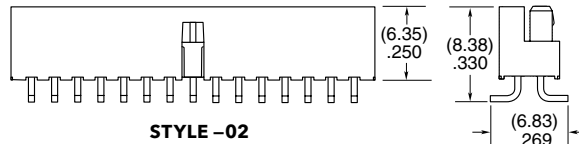
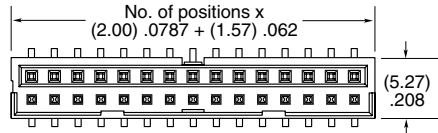

APPLICATION

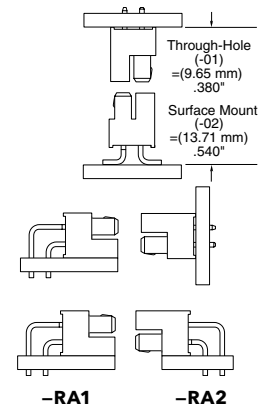

ALSO AVAILABLE

Contact Samtec

Alignment pin
Other platings
Other stack heights

Note:
Some lengths, styles and
options are non-standard,
non-returnable.

PRESS-FIT HEADERS & SOCKETS

(2.54 mm) .100" PITCH • PHT/PHF SERIES

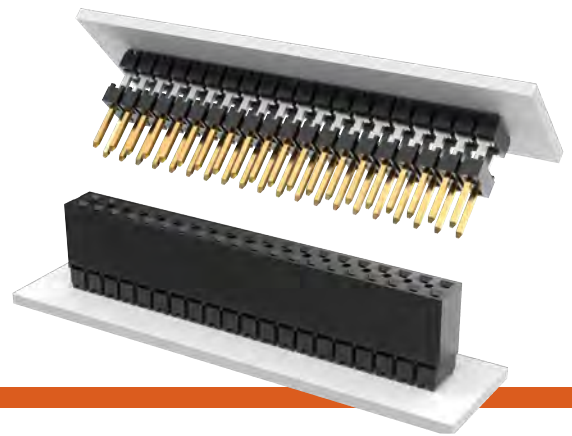

PHT

Board Mates:
SSW, SSQ, ESW,
ESQ, BCS, BSW,
CES, SLW, PHF, SSM

Cable Mates:
IDSJ, IDSS

PHF

Board Mates:
TSW, MTSW, MTLW,
EW, ZW, TSS, ZSS,
TSM, TSSH, PHT, DW, HW

SPECIFICATIONS

Insulator Material:
Liquid Crystal Polymer
Contact Material:
Phosphor Bronze
Plating:
Au or Sn over
50 μm (1.27 μm) Ni
Operating Temp Range:
-55 °C to +125 °C with Gold
Current Rating (PHT/PHF):
4.8 A per pin
(2 pins powered)
(PHF) Insertion Depth:
(3.68 mm) .145" to
(6.35 mm) .250"



NO. PINS PER ROW
01
= (single row only)
02 thru 50

LEAD STYLE
Specify
LEAD
STYLE
from
chart

PLATING OPTION
-L
= 10 μm (0.25 μm)
Gold on post,
Matte Tin on tail

ROW OPTION
-S
= Single
Row
-D
= Double
Row

OTHER OPTION
-"XXX"
= Polarized
Position

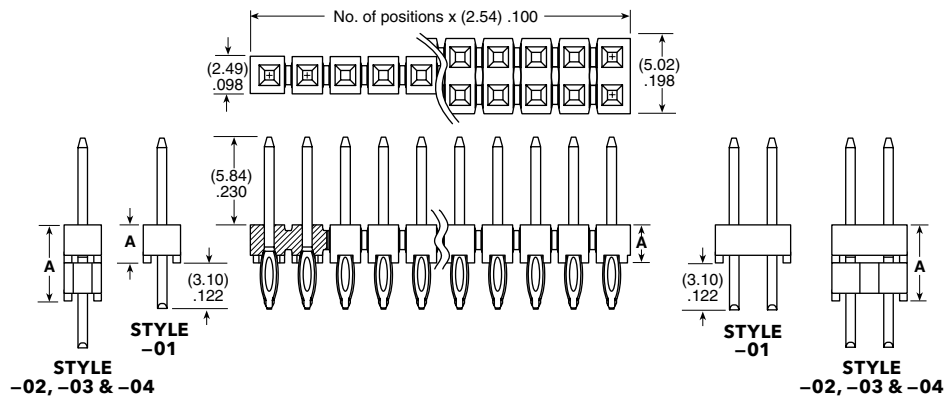

PROCESSING

Contact ipg@samtec.com



NO. PINS PER ROW
01
= (single row only)
02 thru 50

LEAD STYLE
Specify
LEAD
STYLE
from
chart

PLATING OPTION
-L
= 10 μm (0.25 μm)
Gold on post,
Matte Tin on tail

ROW OPTION
-S
= Single
Row
-D
= Double
Row

OTHER OPTION
-"XXX"
= Polarized
Position

ALSO AVAILABLE

Contact Samtec

Other Platings

TOOLING

Press-Fit
PHT: CAT-PT-PH-1XX-X-X
PHF: CAT-PT-PH-1XX-X-B
For more information, visit
www.samtec.com/tooling

Note:
Some lengths, styles and
options are non-standard,
non-returnable.

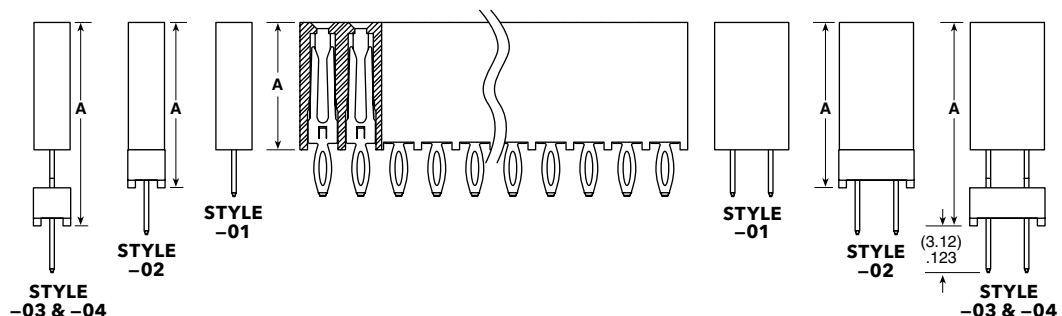
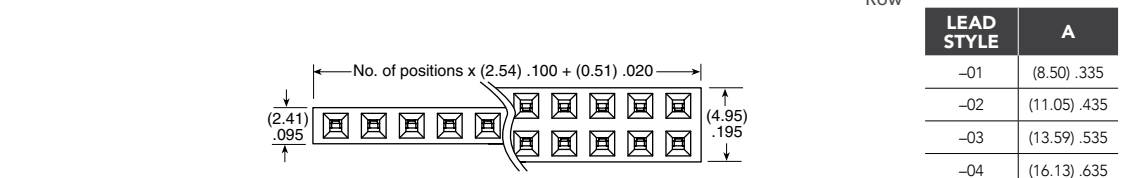

THROUGH-HOLE .025" SQ POST HEADER

(2.54 mm) .100" PITCH • TSW/HTSW SERIES

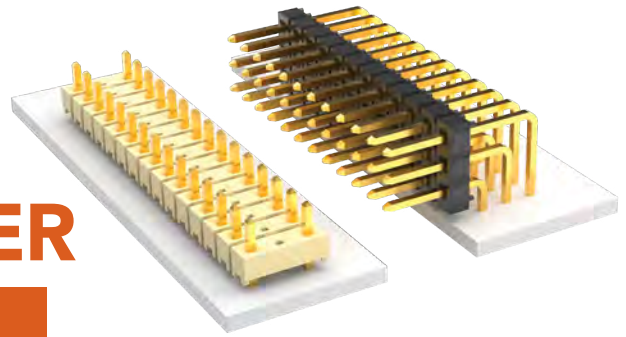

TSW/HTSW

Board Mates:

SSW, SSQ, SSM, ESW, ESQ,
BCS, BSW, CES, SLW

Cable Mates:

IDSD, IDSS

SPECIFICATIONS

Insulator Material:

TSW: PBT

HTSW: Natural LCP

Terminal Material:

Phosphor Bronze

Plating:

Au or Sn over 50 μ" (1.27 μm) Ni

Operating Temp Range:

-55 °C to +125 °C with Gold

-55 °C to +105 °C with Tin

Voltage Rating:

465 VAC/658 VDC

mated with SSW;

500 VAC/707 VDC

mated with BCS;

515 VAC/728 VDC

mated with ESQ;

450 VAC/636 VDC -RA/-RE

mated with BCS or SSM;

400 VAC/566 VDC

mated with CES

Lead-Free Solderable:

HTSW: Yes

TSW: No, Lead Wave Only

CURRENT RATING (PER PIN)

TSW mated with

ESW	SSW	SLW	SSQ	SSM	BCS	SNT
5.2 A	5.7 A	5.2 A	6.3 A	5.2 A	4.6 A	4.3 A

2 POSITIONS POWERED

SERIES

TSW
= Standard Strip

HTSW
= Hi-Temp Strip

PIN CENTERS

-1
= .100" (2.54 mm) Centers,
(All positions filled)

-2
= .200" (5.08 mm) Centers,
(Every other position filled)

NO. PINS PER ROW

01 thru 50
= .100" (2.54 mm)
Center Version

02 thru 25
= .200" (5.08 mm)
Center Version

LEAD STYLE

Specify
LEAD STYLE
from chart

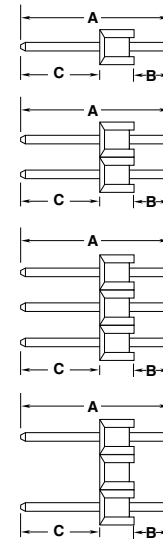
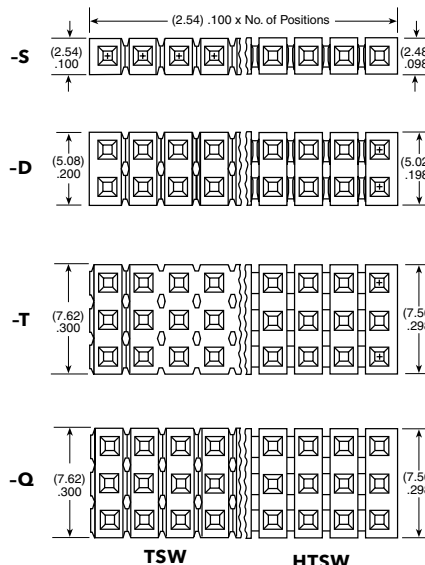

Straight Pin Versions

ALSO AVAILABLE

Contact Samtec

Other Platings

OTHER SOLUTIONS

Elevated Right-angle option
Shunts

STRAIGHT PIN VERSIONS

LEAD STYLE	A	B	C
*-05	(8.51) .335	(3.30) .130	(2.67) .105
*-06	(7.62) .300	(2.41) .095	(2.67) .105
*-07	(10.92) .430	(2.54) .100	
*-08	(13.46) .530	(5.08) .200	
-09	(18.54) .730	(10.16) .400	
-10	(21.08) .830	(12.70) .500	(5.84) .230
-11	(23.62) .930	(15.24) .600	
-12	(26.16) 1.030	(17.78) .700	
-13	(31.24) 1.230	(22.86) .900	
-14	(13.46) .530	(2.79) .110	(8.13) .320
*-15	(18.54) .730	(7.87) .310	(13.21) .520
*-16	(21.08) .830	(7.87) .310	(8.13) .320
*-17	(21.08) .830	(2.79) .110	(15.74) .620
*-18	(23.62) .930	(2.79) .110	(18.29) .720

* Available with -LL (Locking Lead) Option

Specify -07 for best mate with IDXX Series IDC Cable

STRAIGHT PIN VERSIONS

LEAD STYLE	A	B	C
*-19	(26.16) 1.030	(2.79) .110	(20.83) .820
*-20	(31.24) 1.230	(2.79) .110	(25.91) 1.020
*-21	(36.32) 1.430	(2.79) .110	(30.99) 1.220
*-22	(16.00) .630	(7.62) .300	(5.84) .230
*-23	(11.30) .445	(2.92) .115	(6.73) .265
*-24	(12.15) .480	(5.33) .210	(8.13) .320
*-25	(16.00) .630	(5.33) .210	(8.13) .320
▲-26	(11.58) .456	(3.20) .126	(5.84) .230
-27	(33.78) 1.330	(25.40) 1.000	(5.84) .230
-28	(28.70) 1.130	(20.32) .800	(8.13) .320
-29	(33.78) 1.330	(23.11) .910	(8.13) .320
-30	(28.70) 1.130	(18.03) .710	(8.13) .320
+ -41	(9.27) .365	(0.89) .035	(5.84) .230
+ -42	(11.94) .470	(1.27) .050	(8.13) .320

† Style -41 & -42 available with HTSW only.

▲ Except: Style -26 (0.46) .018 DIA Tail

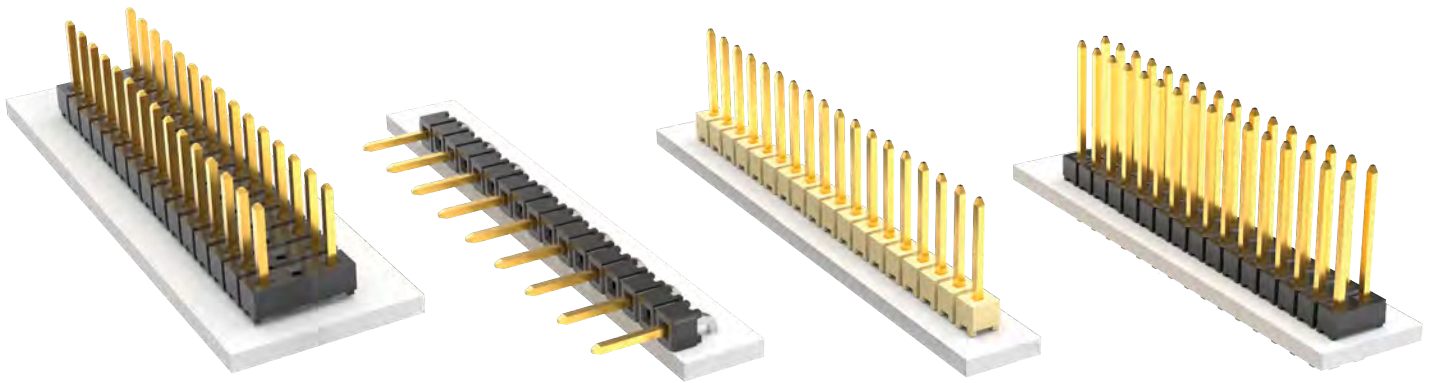

PLATING OPTION

- F**
= Gold flash on post, Matte Tin on tail
- GF**
= 3 μ" (0.07 μm) Gold on post and tail
- L**
= 10 μ" (0.25 μm) Gold on post, Matte Tin on tail
- T**
= Matte Tin

ROW OPTION

- S**
= Single Row
- D**
= Double Row
- T**
= Triple Row
- Q**
= Double Row
(5.08 mm) .200" row space

OTHER OPTION

- RA or -RE**
= Right-angle
- NA**
= Right-angle
(Using straight body for coplanar mating with SSW-RA series)
- LL**
= Locking Lead
See charts for available styles.
Not available with single row
1 or 2 positions.
Recommended hole size
(1.02 mm ± 0.03 mm) .040" ± .001
- LC**
= Locking Clip
(Styles -08 thru -13 & -22 only)
(Requires 4 pin minimum)
(Not available with T, -Q, -RA or -RE)
- LA**
= -RA Option with -LL Option
- "XXX"**
= Polarized Position

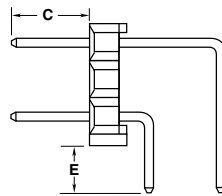
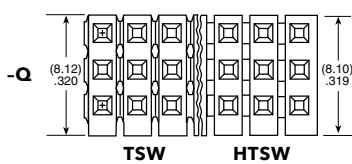
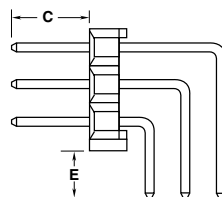
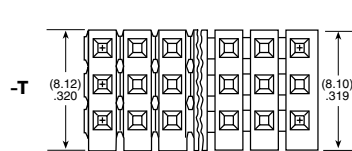
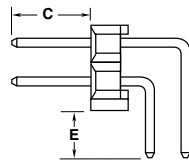
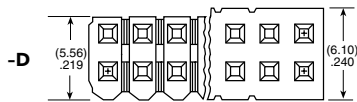
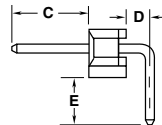
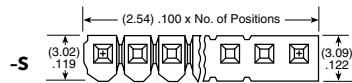

Right-Angle Versions

LEAD STYLE	D
-RA	(1.52) .060
-RE	(4.06) .160

RIGHT-ANGLE VERSIONS		
-RE LEAD STYLE	C	SINGLE E
-09		(4.83) .190
-10		(7.37) .290
-11	(5.84) .230	(9.91) .390
-12		(12.45) .490
-13		(17.53) .690
-16	(8.13) .320	(2.54) .100
-21		(22.61) .890
-22	(5.84) .230	(2.29) .090
-27		(20.07) .790
-28		(14.99) .590

-RA LEAD STYLE	RIGHT-ANGLE VERSIONS			
	SINGLE (-S)		DOUBLE (-D)	TRIPLE (-T & -Q)
	C	E	E	E
-08		(2.29) .090	(2.29) .090	(2.29) .090
-09		(7.37) .290	(7.37) .290	(7.37) .290
-10		(9.91) .390	(9.91) .390	(9.91) .390
-11	(5.84) .230	(12.45) .490	(12.45) .490	(12.45) .490
-12		(14.99) .590	(14.99) .590	(14.99) .590
-13		(20.07) .790	(20.07) .790	N/A
*-16	(8.13) .320	(5.08) .200	(5.08) .200	(5.08) .200
-21		(25.15) .990	N/A	N/A
*-22	(5.84) .230	(4.83) .190	(4.83) .190	(4.83) .190
*-25	(8.13) .320	(2.54) .100	(2.54) .100	(2.54) .100
-27		(22.61) .890	N/A	
-28	(5.84) .230	(17.53) .690	(17.53) .690	
-29		(20.32) .800	N/A	
-30	(8.13) .320	(15.24) .600	(15.24) .600	N/A

* Available with -LA (Locking Lead) Option

SURFACE MOUNT .025" SQ POST HEADER

(2.54 mm) .100" PITCH • TSM SERIES

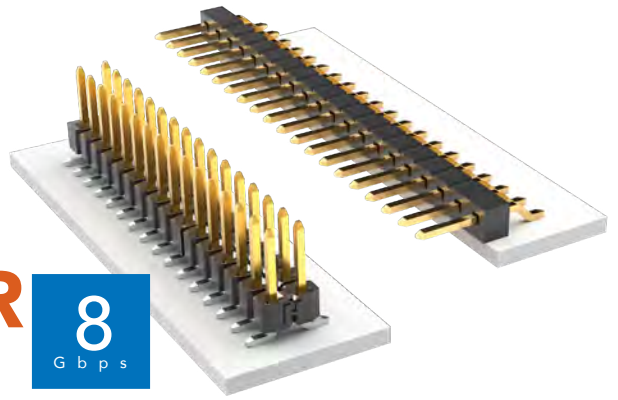

TSM

Board Mates:

SSW, SSQ, SSM, BSW, ESW, ESQ, BCS, SLW, CES, HLE

Cable Mates:

IDSS, IDSD



02 thru 36

Specify
LEAD STYLE
from chart

SPECIFICATIONS

Insulator Material:

Black Liquid Crystal Polymer

Terminal Material:

Phosphor Bronze

Plating:

Au or Sn over

50 μ" (1.27 μm) Ni

Operating Temp Range:

-55 °C to +105 °C with Tin;

-55 °C to +125 °C with Gold

Voltage Rating:

495 VAC/700 VDC -SV/-DV

mated with the BCS

405 VAC/573 VDC -SV/-DV

mated with the SSM

400 VAC/566 VDC

mated with HLE

PROCESSING

Lead-Free Solderable:

Yes

-DH/-SH/-SV Lead Coplanarity:

(0.15 mm) .006" max (02-36)*

-DV Lead Coplanarity:

(0.10 mm) .004" max (02-05)

(0.13 mm) .005" max (06-10)*

(0.15 mm) .006" max (11-36)*

*(.004" stencil solution

may be available; contact

ipg@samtec.com)

MATES	CURRENT RATING (PER PIN)
TSM/SSW	4.7 A
TSM/SSM	5.6 A
TSM/HLE	4.1 A
TSM/BCS	5.0 A

2 POSITIONS POWERED

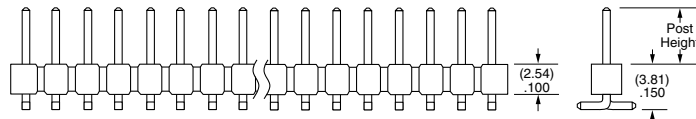
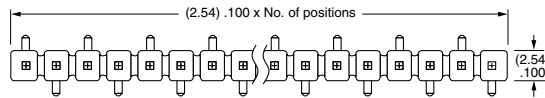

-SV Row Option

LEAD STYLE	POST HEIGHT	MATES WITH
-01	(5.84) .230	SSW, BCS, SSM, IDSS, IDSD
-02	(8.13) .320	SSM-DH
-03	(10.67) .420	Bottom Mount & Pass-Through
-04	(3.05) .120	SLW, CES, HLE

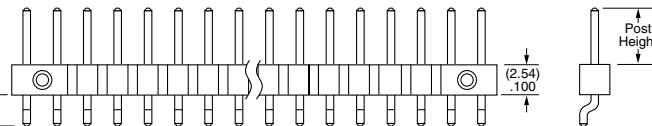
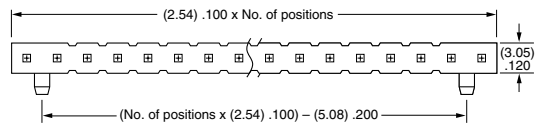

-SH Row Option

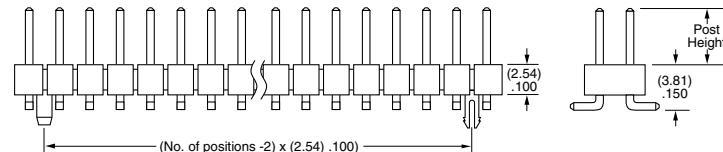
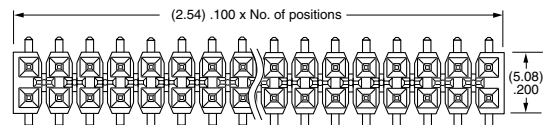

-DV Row Option

Notes:

Severe Environment Testing qualified; aligns with MIL-DTL-55302. Visit samtec.com/set

Some sizes, styles and options are non-standard, non-returnable.

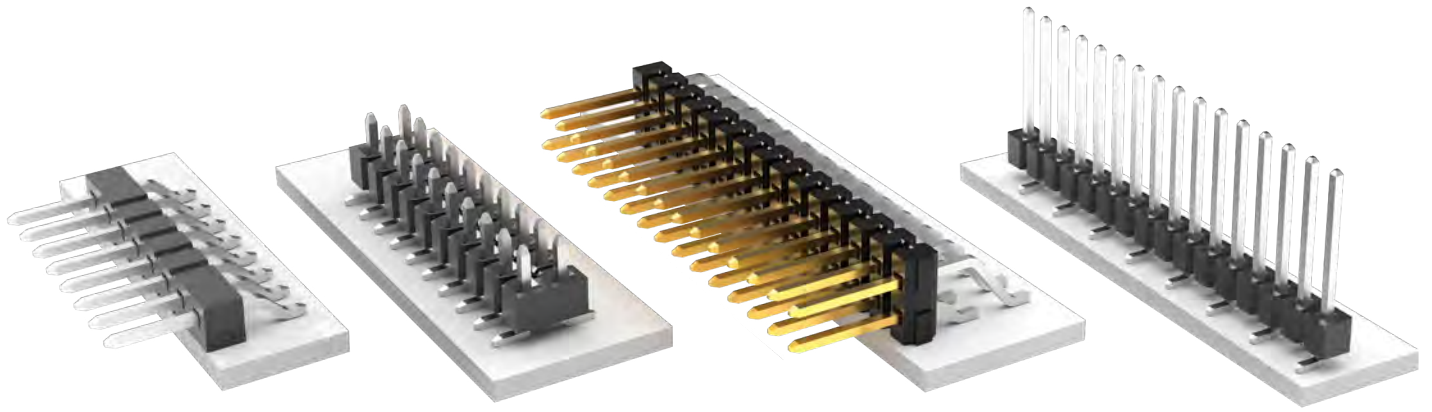

PLATING OPTION

-F
= Gold flash on post, Matte Tin on tail

-L
= 10 μ m (0.25 μ m) Gold on post,
Matte Tin on tail

-T
= Matte Tin

ROW OPTION

-SV
= Single Row Vertical Pin

-DV
= Double Row Vertical Pin

-SH
= Single Row Horizontal Pin

-DH
= Double Row Horizontal Pin

-TM
= Triple Row Vertical Mixed Technology
(Style -01 only)
(02 thru 30 positions only)

-MT
= Mixed Technology Pin
(Style -01, -02 or -03 only)

OTHER OPTIONS

-"XXX"
= Polarized Position

-A
= Alignment Pin
metal or plastic at Samtec discretion
(Not available with -TM or -MT)
(02 positions minimum)
(Not available with -LC)

-LC
= Locking Clip
(Not available with -TM)
(3 positions minimum)
(Not available with -A)
(Manual placement required)

-K
= (6.50 mm) .256" DIA
Polyimide Film Pick & Place Pad
(-SH: 4 positions minimum without -TR;
2 & 3 positions available with -TR)
(-DH: 4 positions minimum without -TR)

-P
= Plastic Pick & Place Pad
(-DV: 4 positions minimum without -TR;
2 & 3 positions available with -TR)
(-SH: 4 positions minimum without -TR;
2 & 3 positions available with -TR)
(-DH: 5 positions minimum without -TR)
(-SV: 4 positions minimum without -TR;
2 & 3 positions available with -TR)

-TR
= Tape & Reel
-SV: 02-22 positions, -DV: 02-28 positions,
-SH: 02-30 positions, -DH: 02-29 positions
(Not available with -MT or -TM)

-FR
= Full Reel Tape & Reel
(must order maximum quantity per reel;
contact Samtec for quantity breaks)
-SV: 02-22 positions, -DV: 02-28 positions,
-SH: 02-30 positions, -DH: 02-29 positions
(Not available with -MT or -TM)

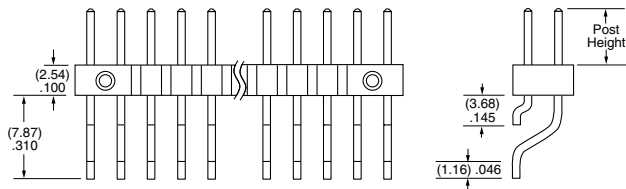
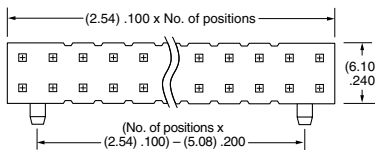

-DH Row Option

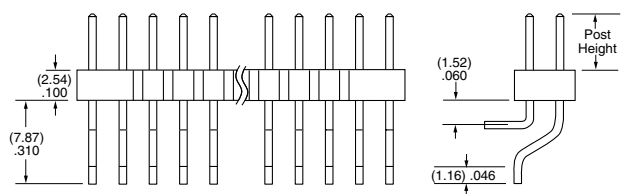
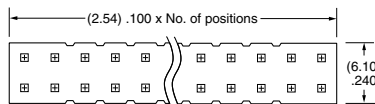

-MT Row Option

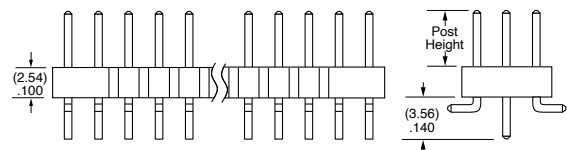
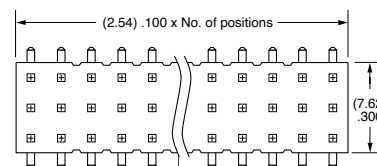

-TM Row Option

MODIFIED .025" SQ POST HEADERS

(2.54 mm) .100" PITCH • MTSW/HMTSW SERIES

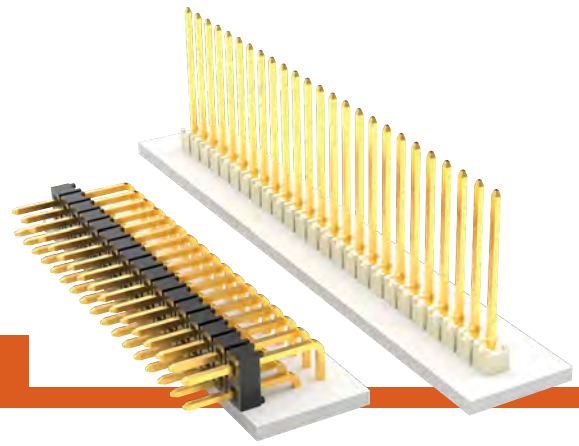

MTSW/HMTSW

Board Mates:

SSW, SSQ, ESW,
ESQ, BCS, BSW
CES, SLW, HLE, SSM

Cable Mates:

IDSD, IDSS

SPECIFICATIONS

Insulator Material:

MTSW: Black Glass
Filled Polyester
HMTSW: Natural Liquid
Crystal Polymer

Terminal Material:

Phosphor Bronze

Plating:

Au or Sn over
50 μm (1.27 μm) Ni

Operating Temp Range:

-55 °C to +125 °C with Gold
-55 °C to +105 °C with Tin

PROCESSING

Lead-Free Solderable:

MTSW: No, Lead Wave Only
HMTSW: Yes

SERIES	PIN CENTERS	NO. PINS PER ROW	LEAD STYLE
MTSW = Modified Strip	-1 = (2.54 mm) .100" Pitch (All positions filled)	01 thru 50 = .100" (2.54 mm) Center Version	Specify LEAD STYLE from chart
HMTSW = Hi-Temp Modified Strip	-2 = (5.08 mm) .200" Pitch (Every other position filled)	02 thru 25 = .200" (5.08 mm) Center Version	

LEAD STYLE	OAL
-05	(8.51) .335
-06	(7.62) .300
-07	(10.92) .430
-08	(13.46) .530
-09	(18.54) .730
-10	(21.08) .830
-11	(23.62) .930
-12	(26.16) 1.030
-13	(31.24) 1.230
-21	(36.32) 1.430
-22	(16.00) .630
-23	(11.30) .445
-24	(12.19) .480
-27	(33.78) 1.330
-28	(28.70) 1.130

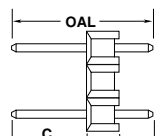
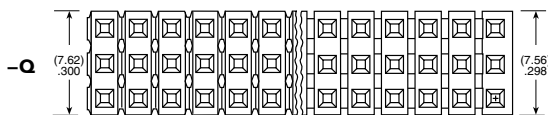
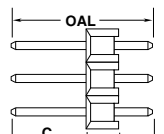
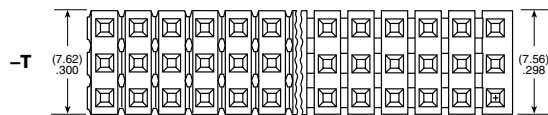
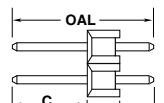
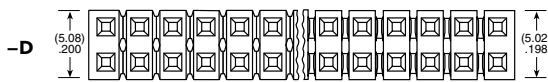
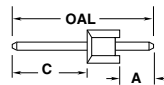
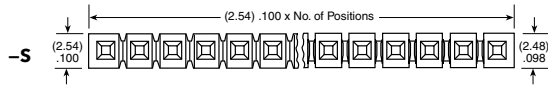
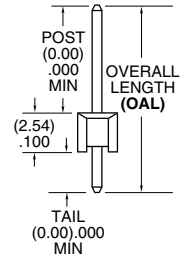

MTSW

HMTSW

Straight Pin Versions: A=OAL-C- (2.54) .100"

FOR "A" = (2.29) .090		
LEAD STYLE	OAL	C MAXIMUM STRAIGHT
-05	(8.51) .335	(5.97) .235
-06	(7.62) .300	(2.79) .110
-07	(10.92) .430	(6.10) .240
-08	(13.46) .530	(8.64) .340
-09	(18.54) .730	(13.72) .540
-10	(21.08) .830	(16.26) .640
-11	(23.62) .930	(18.80) .740
-12	(26.16) 1.030	(21.34) .840
-13	(31.24) 1.230	(26.42) 1.040
-21	(36.32) 1.430	(31.50) 1.240
-22	(16.00) .630	(11.18) .440
-23	(11.30) .445	(6.48) .255
-24	(12.19) .480	(7.37) .290
-27	(33.78) 1.330	(28.96) 1.140
-28	(28.70) 1.130	(23.88) .940

Note:

These Series are non-standard, non-returnable.

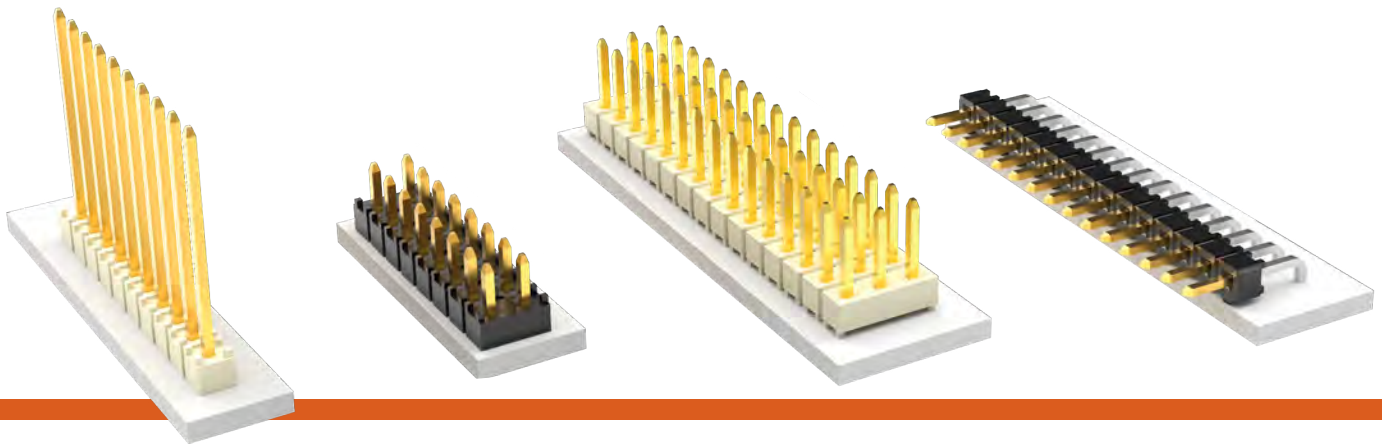

PLATING OPTION

- F**
= Gold flash on post,
Matte Tin on tail
- L**
= 10 μ" (0.25 μm)
Gold on post,
Matte Tin on tail
- G**
= 10 μ" (0.25 μm)
Gold on post,
Gold flash on balance
- T**
= Matte Tin

ROW OPTION

- S**
= Single Row
- D**
= Double Row
- T**
= Triple Row
- Q**
= Double Row
.200" (5.08 mm)
row space

POST HEIGHT

"XXXX"
= "C" Dimension
(Specify post height in
INCHES
.005" (0.13 mm) increments)

OTHER OPTION

- RA or -RE**
= Right-angle
(HMTSW -S & -D =
36 positions maximum)
- LL**
= Locking Lead
(not available with -RE, not available
in single row 1 or 2 positions)
(Available on tails from (2.29 mm) .090"
to (10.16 mm) .400" only)
- LA**
= -RA option with -LL Option
(Maximum "C" = (13.46 mm) .530")

POLARIZED OPTION

"XXX"
= Polarized
(Specify "XXX" as position number)

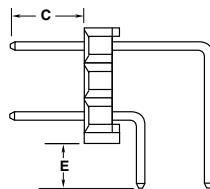
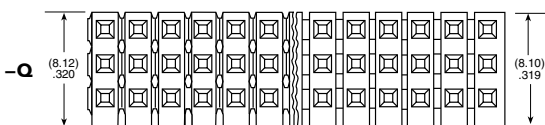
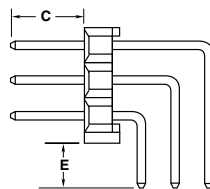
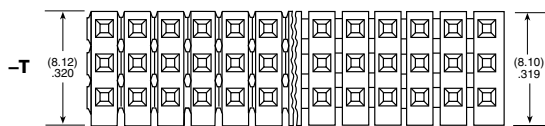
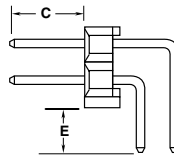
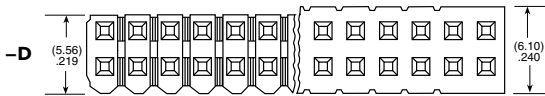
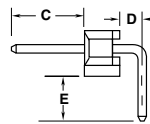
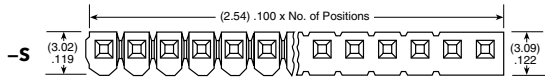

MTSW

HMTSW

-RX OPTION	D
-RA	(1.52) .060
-RE	(4.06) .160

FOR "E" = (2.29) .090 MIN FOR -RA & -RE			
LEAD STYLE	OAL	C MAXIMUM with/-RA	C MAXIMUM with/-RE
-05	(8.51) .335	Not Available	Not Available
-06	(7.62) .300	Not Available	Not Available
-07	(10.92) .430	(3.30) .130	Not Available
-08	(13.46) .530	(5.84) .230	(3.30) .130
-09	(18.54) .730	(10.92) .430	(8.38) .330
-10	(21.08) .830	(13.46) .530	(10.92) .430
-11	(23.62) .930	(16.00) .630	(13.46) .530
-12	(26.16) 1.030	(18.54) .730	(16.00) .630
*-13	(31.24) 1.230	(23.62) .930	(21.08) .830
*-21	(36.32) 1.430	(28.70) 1.130	(26.16) 1.030
-22	(16.00) .630	(8.38) .330	(5.84) .230
*-23	(11.30) .445	(3.68) .145	Not Available
*-24	(12.19) .480	(4.57) .180	
*-27	(33.78) 1.330	(26.16) 1.030	(23.62) .930
*-28	(28.70) 1.130	(21.08) .830	(18.54) .730

* Styles -21, -23, -24, -27 not available with -D Right-angle
Styles -13, -21, -23, -24, -27, -28 not available with -T or -Q Right-angle

Right-Angle Versions (- RA Options): E=OAL-C- (5.33) .210"

Right-Angle Versions (-RE Options) Single Row Only: E=OAL-C- (7.87) .310"

LOW PROFILE .025" SQ POST HEADERS

(2.54 mm) .100" PITCH • TLW/MTLW SERIES

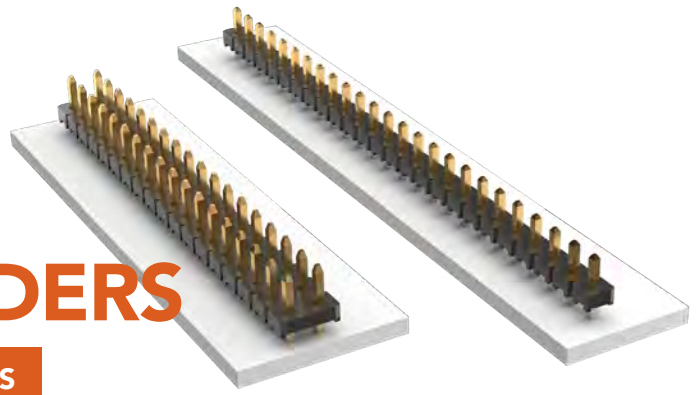

TLW/MTLW

Board Mates:
BSW, CES, SLW, HLE

FEATURES

These headers provide the ultimate low profile (0.64 mm) .025" square post board stacking system. The high quality Phosphor Bronze terminals are available with a standard short post height (TLW Series) for mating with low profile sockets, or the post height can be Modified (MTLW Series) to accommodate IDC assemblies and other applications.

SPECIFICATIONS

Insulator Material:
Black Liquid Crystal Polymer
Terminal Material:
Phosphor Bronze
Plating:
Au or Sn over
50 μ" (1.27 μm) Ni
Operating Temp Range:
-55 °C to +105 °C with Tin
-55 °C to +125 °C with Gold
Current Rating (TLW/SLW):
5.2 A per pin
(2 pins powered)
Voltage Rating:
406 VAC/574 VDC

PROCESSING

Lead-Free Solderable:
Yes

ALSO AVAILABLE

Contact Samtec

Other platings
Notch option

Note:
Some lengths, styles and options are non-standard, non-returnable. MTLW Series is non-standard, non-returnable.

TLW	1	NO. PINS PER ROW	LEAD STYLE	PLATING OPTION	ROW OPTION	OTHER OPTION
-----	---	------------------	------------	----------------	------------	--------------

01 thru 40
= Single Row
01 thru 36
= Double Row

Specify **LEAD STYLE** from chart

-F
= Gold flash on post, Matte Tin on tail
-G
= 10 μ" (0.25 μm) Gold on post, Gold flash on tail
-T
= Matte Tin

-S
= Single Row
-D
= Double Row

-RA
= Right-angle (-01 Lead Style only)
"-XX"
= Polarized Position Specify position for omitted pin.

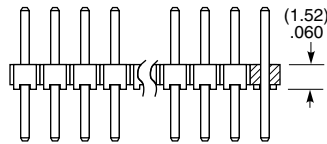
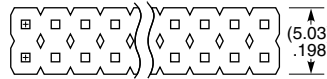
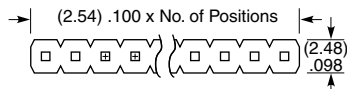

-05 & -06

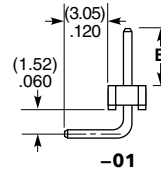

LEAD STYLE	A	B
-01	N/A	(5.84) .230
-05	(4.32) .170	(2.67) .105
-06	(3.43) .135	

MTLW	1	NO. PINS PER ROW	LEAD STYLE	PLATING OPTION	ROW OPTION	POST HEIGHT
------	---	------------------	------------	----------------	------------	-------------

01 thru 40
= Single Row
01 thru 36
= Double Row

Specify **LEAD STYLE** from chart

-F
= Gold flash on post, Matte Tin on tail
-L
= 10 μ" (0.25 μm) Gold on post, Matte Tin on tail
-G
= 10 μ" (0.25 μm) Gold on post, Gold flash on tail
-T
= Matte Tin

"-XXX"
= Post Height Dimension (In inches)
-D
= Double Row

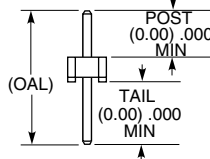
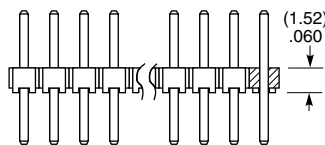
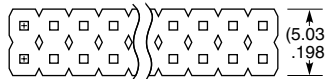
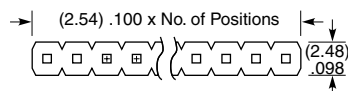

LEAD STYLE	OAL
-05	(8.51) .335
-06	(7.62) .300
-07	(10.92) .430
-08	(13.46) .530
-09	(18.54) .730
-10	(21.08) .830
-22	(16.00) .630
-23	(11.30) .445
-24	(12.19) .480

FLEX STACK

FLEXIBLE .025" SQ BOARD STACKERS

(2.54 mm) .100" PITCH • HW SERIES

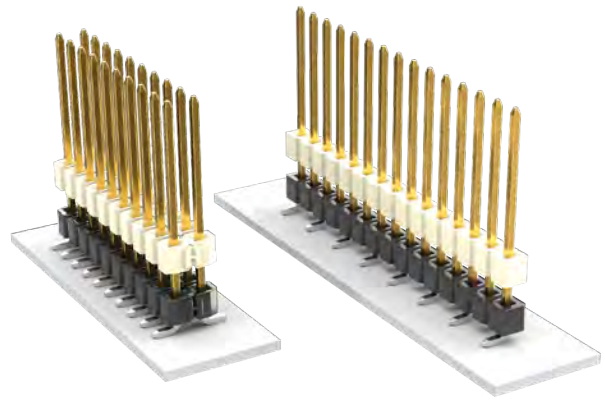

HW

Board Mates:

SSW, SSQ, ESW, ESQ, CES, SLW, BSW, BCS, SSM, HLE, PHF

Cable Mates:

IDSS, IDSD

SPECIFICATIONS

Insulator Material:

HW-SM Top = Natural LCP
HW-SM Bottom = Black LCP
HW-TH = Natural LCP

Terminal Material:

Phosphor Bronze

Plating:

Au or Sn over
50 μm (1.27 μm) Ni

Operating Temp Range:

-55 °C to +125 °C with Gold
-55 °C to +105 °C with Tin

PROCESSING

Lead-Free Solderable:

Yes

SMT Lead Coplanarity:

(0.15 mm) .006" max*
*(.004" stencil solution may be available; contact ipg@samtec.com)

ALSO AVAILABLE

Contact Samtec

Other platings

Locking Clip available with double row HW-SM
(Manual placement required)

Notes:

For added mechanical stability, Samtec recommends mechanical board spacers be used in applications with gold or selective gold plated connectors. Contact ipg@samtec.com for more information.

This Series is non-standard, non-returnable.

HW	NO. PINS PER ROW	LEAD STYLE	PLATING OPTION	ROW OPTION	STACKER HEIGHT	SM	OTHER OPTION
----	------------------	------------	----------------	------------	----------------	----	--------------

01 thru 50
(Through-hole)

02 thru 36
(Surface mount)

Specify LEAD STYLE from chart

-F
= Gold flash on contact, Matte Tin on tail

-L
= 10 μm (0.25 μm) Gold on contact area of longer tail, Matte Tin on tail

-G
= 10 μm (0.25 μm) Gold on contact area of longer tail, Gold flash on balance

-T
= Matte Tin

-S
= Single Row

-D
= Double Row

-T
= Triple Row (Through-hole only)

-Q
= Double Row .200" (5.08 mm) row space (Through-hole only)

-"XXX"
= Stacker Height (in inches)

Through-hole = (5.08 mm) .200" Min.

Surface mount = (6.35 mm) .250" Min.

Leave blank for Through-hole

-"XXX"

= HW-TH Tail Length (in inches) (1.40 mm) .055" min. Example: -250 = (6.35 mm) .250"

-LL

= Locking Lead (Through-hole only) (Shortest dimension between the tail and the post is the end that will be crimped. Available on tails from (2.29 mm) .090" to (7.87 mm) .310" only.) Single row, 01 & 02 positions & -Q row not available

-"XXX"
= Polarized (Specify omitted pin position)

-A
= Alignment Pin (Metal or plastic at Samtec discretion) (Surface mount only)

-TR

= Tape & Reel (4-27 pins per row only) (Not Available on Lead Styles 10, 11, 12 & 20) (Surface mount only)

-FR

= Full Reel Tape & Reel (must order max. quantity per reel; contact Samtec for quantity breaks) (4-27 pins per row only) (Not Available on Lead Styles 10, 11, 12 & 20) (Surface mount only)

LEAD STYLE	OAL (TH)
-07	(10.92) .430
-08	(13.46) .530
-09	(18.54) .730
-10	(21.08) .830
-11	(23.62) .930
-12	(26.16) 1.030
-13	(31.24) 1.230
-14	(36.32) 1.430
-15	(16.00) .630
-16	(11.30) .445
-17	(12.19) .480
-19	(33.78) 1.330
-20	(28.70) 1.130

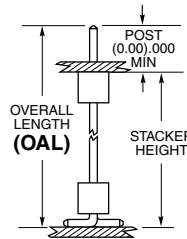

LEAD STYLE	OAL (SMT)
-08	(11.81) .465
-09	(16.89) .665
-10	(19.43) .765
-11	(21.97) .865
-12	(24.51) .965
-15	(14.35) .565
-16	(9.65) .380
-17	(10.54) .415
-20	(27.05) 1.065

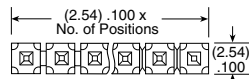

-S

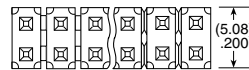

-D

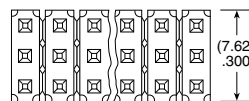

-T or -Q*

-Q* same as -T except middle row pins are removed

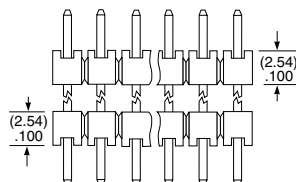

HW-TH

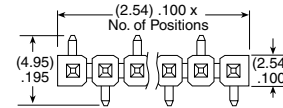

-S

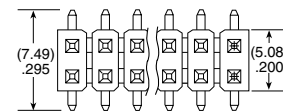

-D

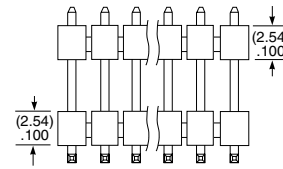

HW-SM

FLEXIBLE .025" SQ BOARD STACKERS

(2.54 mm) .100" PITCH • DW/EW/ZW SERIES

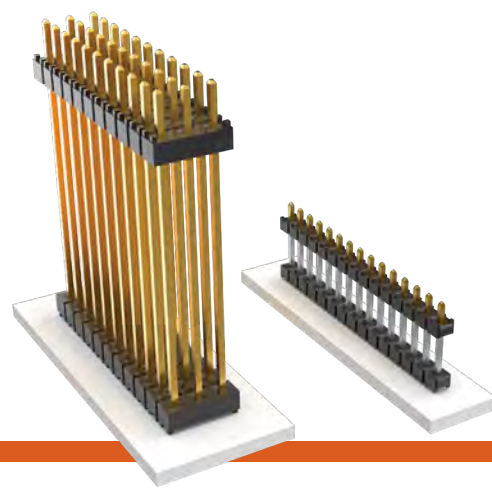

DW/EW/ZW

Board Mates:

SSW, SSQ, ESW, ESQ, CES, SLW, BSW, BCS, SSM, HLE, PHF

Cable Mates:

IDSS, IDSD

SPECIFICATIONS

Insulator Material:

Black Glass Filled Polyester

Terminal Material:

Phosphor Bronze

Plating:

Au or Sn over
50 μ" (1.27 μm) Ni

Operating Temp Range:

-55 °C to +125 °C with Gold
-55 °C to +105 °C with Tin

PROCESSING

Lead-Free Solderable:

No, Lead Wave Only

SERIES	NO. PINS PER ROW	LEAD STYLE	PLATING OPTION	ROW OPTION	STACKER HEIGHT	OTHER OPTION
DW = (2.79 mm) .110" Tail	01 thru 50	Specify LEAD STYLE from chart	-F = Gold flash on contact, Matte Tin on tail	-S = Single Row	-"XXX" = Stacker Height (inches) (5.08 mm) .200" minimum	-"XXX" = ZW Tail Length (inches) (1.40 mm) .055" minimum
EW = (8.38 mm) .330" Tail			-L = 10 μ" (0.25 μm) Gold on contact area of longer tail, Matte Tin on tail	-D = Double Row	Example: -250 = (6.35 mm) .250"	Example: -250 = (6.35 mm) .250"
ZW = Custom Tail			-G = 10 μ" (0.25 μm) Gold on contact area of longer tail, Gold flash on balance	-T = Triple Row		-LL = Locking Lead (Shortest dimension between the tail and the post is the end that will be crimped. Available on tails from (2.29 mm) .090" to (7.87 mm) .310" only.) Single row, 01 & 02 positions & -Q row not available
			-T = Matte Tin	-Q = Double Row .200" (5.08 mm) row space		-"XXX" = Polarized (Specify omitted pin position)

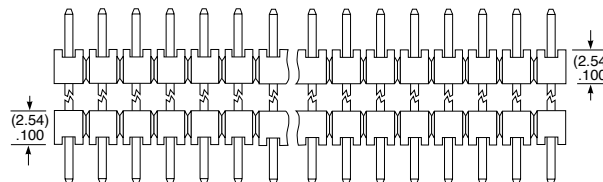
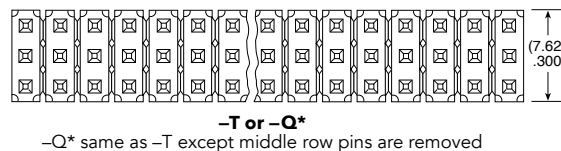
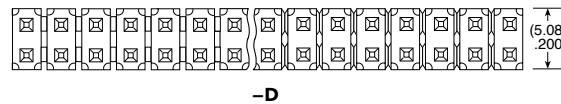
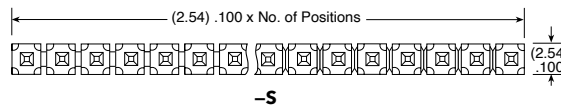

LEAD STYLE	OAL
-07	(10.92) .430
-08	(13.46) .530
-09	(18.54) .730
-10	(21.08) .830
-11	(23.62) .930
-12	(26.16) 1.030
-13	(31.24) 1.230
-14	(36.32) 1.430
-15	(16.00) .630
-16	(11.30) .445
-17	(12.19) .480
-19	(33.78) 1.330
-20	(28.70) 1.130

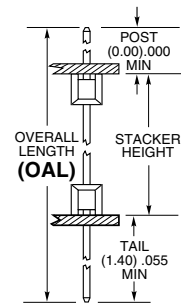

Notes:

For added mechanical stability, Samtec recommends mechanical board spacers be used in applications with gold or selective gold plated connectors. Contact jpg@samtec.com for more information.

This Series is non-standard, non-returnable.

SHROUDED .025" SQ POST HEADERS

(2.54 mm) .100" PITCH • TSS/HTSS/ZSS SERIES

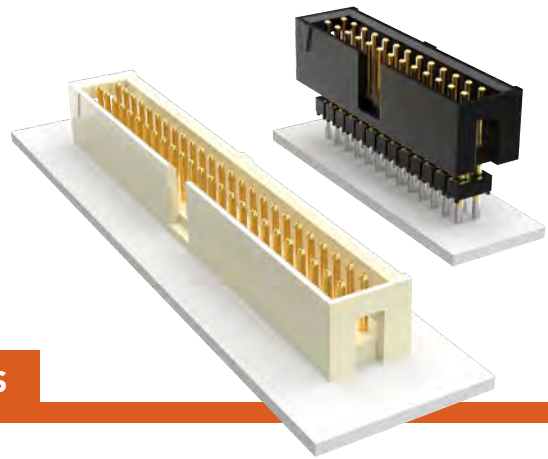

TSS/HTSS/ZSS

Mates:
SSW, SSQ, ESW, ESQ,
SSM, BCS

SPECIFICATIONS

Insulator Material:

TSS, ZSS=Black Glass Filled Polyester
HTSS=Natural PCT

Terminal Material:

Phosphor Bronze
Plating: Au or Sn over 50 μ" (1.27 μm) Ni

Operating Temp Range:

-55 °C to +125 °C with Gold
-55 °C to +105 °C with Tin

PROCESSING

Lead-Free Solderable:

HTSS=Yes
TSS, ZSS=No, Lead Wave only
SMT Lead Coplanarity:
(0.15 mm) .006" max*
*(.004" stencil solution may be available; contact ipg@samtec.com)

SERIES	1	NO. PINS PER ROW	LEAD STYLE	PLATING OPTION	ROW OPTION
--------	---	------------------	------------	----------------	------------

TSS
= Connector Strip

HTSS
= High Temp Connector Strip

03
(TSS only)

05, 07, 08, 10, 12, 13, 15, 17, 20, 25, 32, 36
(Standard sizes)

Specify **LEAD STYLE** from chart

-F
= Gold flash on post, Matte Tin on tail
(Not available on -DV)

-L
= 10 μ" (0.25 μm) Gold on post, Matte Tin on tail

-T
= Matte Tin

-D
= Double Row Through-hole (lead style -01, -02 & -03 only)

-DV
= Double Row Surface Mount (lead style -01 only) (HTSS only)

-D-RA
= Double Row Right-angle (lead style -04 & -05 only)

LEAD STYLE	T/H (A)
-01	(2.92) .115
-02	(4.19) .165
-03	(14.35) .565

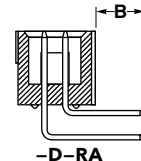
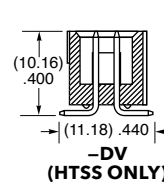
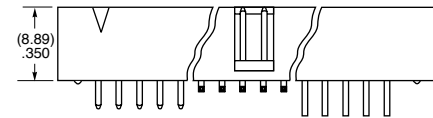
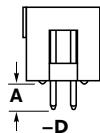
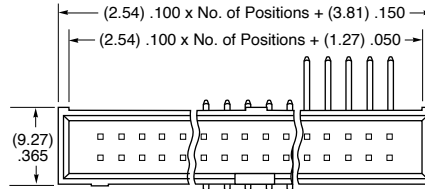

LEAD STYLE	RIGHT ANGLE (B)
-04	(3.30) .130
-05	(5.84) .230

ZSS	1	NO. PINS PER ROW	LEAD STYLE	PLATING OPTION	D	BODY HEIGHT
-----	---	------------------	------------	----------------	---	-------------

03, 05, 07, 08, 10, 12, 13, 15, 17, 20, 25, 32, 36
(Standard sizes)

Specify **LEAD STYLE** from chart

-F
= Gold flash on post, Matte Tin on tail

-L
= 10 μ" (0.25 μm) Gold on post, Matte Tin on tail

-T
= Matte Tin

-"XXXX"
= Body Height

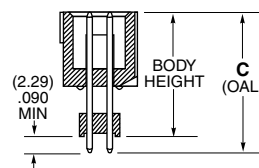
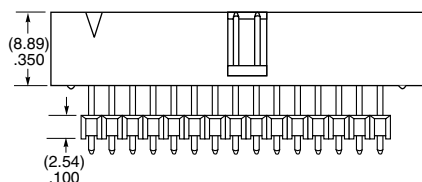
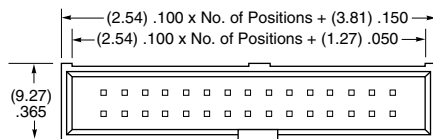

LEAD STYLE	C (OAL)	MAX BODY HEIGHT
-01	(16.00) .630	(13.72) .540
-02	(18.54) .730	(16.26) .640
-03	(21.08) .830	(18.80) .740
-04	(23.62) .930	(21.34) .840
-05	(26.16) 1.030	(23.88) .940
-06	(28.70) 1.130	(26.42) 1.040
-07	(31.24) 1.230	(28.96) 1.140
-08	(33.78) 1.330	(31.50) 1.240
-09	(36.32) 1.430	(34.04) 1.340

Note:
Some lengths, styles and options are non-standard, non-returnable. ZSS is non-standard, non-returnable.

Note:

For added mechanical stability, Samtec recommends mechanical board spacers be used in applications with gold or selective gold plated connectors. Contact ipg@samtec.com for more information.

ALSO AVAILABLE

Contact Samtec

Other sizes
Other platings
Alignment Pins
Single Row
Locking Leads
Polarized

THROUGH-HOLE .025" SQ POST SOCKET

(2.54 mm) .100" PITCH • SSW/SSQ SERIES

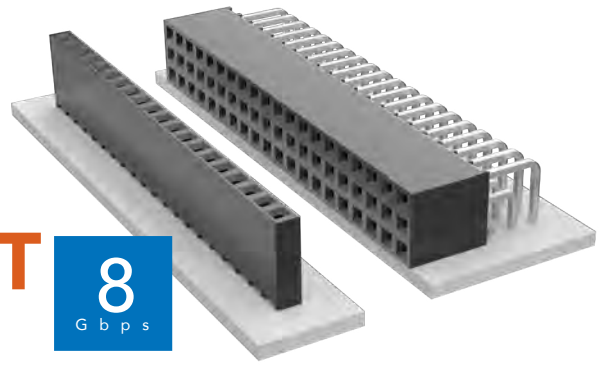

SSW/SSQ

Mates:

TSW, MTSW, MTLW,
DW, EW, ZW, TSS, ZSS,
TSM, TSSH, HTSS

SPECIFICATIONS

Insulator Material:

Black Liquid Crystal Polymer (-S & -D) or
Black High Temperature Thermoplastic (-T)

Contact Material:

Phosphor Bronze

Plating:

Au or Sn over
50 μ" (1.27 μm) Ni

Operating Temp Range:

-55 °C to +125 °C with Gold
-55 °C to +105 °C with Tin

Current Rating:

(SSW/TSM) = 4.7 A per pin
(2 pins powered)
(SSQ/TSW) = 6.3 A per pin
(2 pins powered)

Voltage Rating:

465 VAC/655 VDC

Insertion Depth:

(3.68 mm) .145" to
(6.35 mm) .250"

Max Cycles:

100 with 10 μ" (0.25 μm) Au

PROCESSING

Lead-Free Solderable:

Yes:
-S and -D row option
No, Lead Wave only:
-P, -T and -Q row option

SERIES	1	NO. PINS PER ROW	LEAD STYLE	PLATING OPTION	ROW OPTION	TAIL OPTION	OTHER OPTION
--------	---	------------------	------------	----------------	------------	-------------	--------------

SSW
= Solder Tail

01 thru 50

Specify
LEAD STYLE
from chart

-F
= Gold flash on contact,
Matte Tin on tail

-S
= Single Row

Leave blank for straight pin version)

-LL
= Locking Lead

SSQ
= Square Tail

-L
= 10 μ" (0.25 μm)
Gold on contact,
Matte Tin on tail

-P
= Single Row
(36 pins max)

-RA
= Right-angle

Available on tails from
(2.29 mm) .090" to
(7.87 mm) .310" only.
Not Available with single row 1 or 2 positions)

-G
= 20 μ" (0.51 μm)
Gold on contact,
Gold flash on tail

-D
= Double Row

-T
= Triple Row

-Q
= Double Row
.200"
(5.08 mm)
row space
(outer rows filled only)

"XXX"
= Polarized
(Specify "XXX" as position number)

-T
= Matte Tin
(-T N/A on LIF contacts)

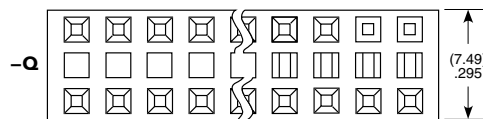
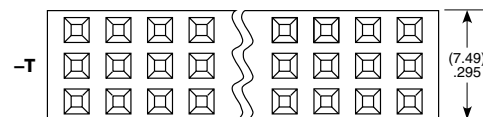
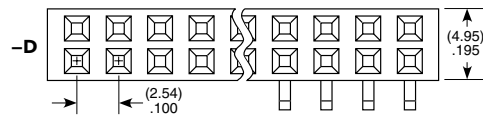
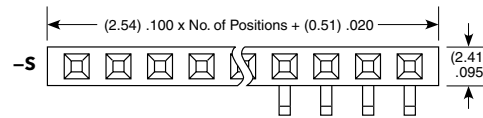

Through-hole

Right-angle

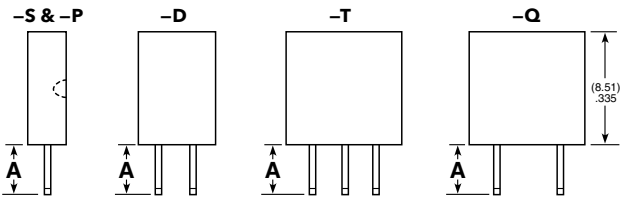

Straight Pin Versions

THROUGH-HOLE

LEAD STYLE		SINGLE DOUBLE OR TRIPLE A
Standard Insertion Force	Low Insertion Force*	
-01	-21	(2.64) .104
-02	-22	(4.93) .194
-03	-23	(10.00) .394
-04	-24	(14.83) .584
-06**	N/A	(3.15) .124

* LIF not available with Tin Plating
** Style -06 Not available with SSQ

RIGHT-ANGLE				
LEAD STYLE		SINGLE	DOUBLE	TRIPLE
Standard Insertion Force	Low Insertion Force*	(-S) B	(-D) B	(-T & -Q) B
-02	-22	(2.54) .100	(2.54) .100	(2.54) .100
-03	-23	(7.62) .300	(7.62) .300	N/A
-04	-24	(12.45) .490	N/A	N/A

*LIF not available with Tin Plating

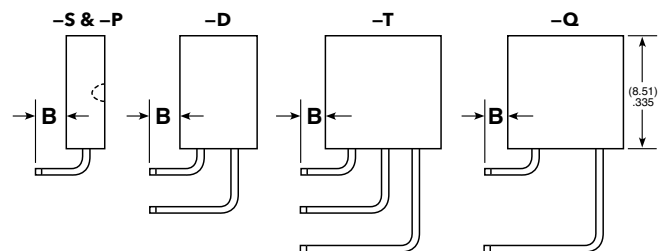

Right-angle Versions

Note:

Some lengths, styles and options are non-standard, non-returnable.

SURFACE MOUNT .025" SQ POST SOCKET

(2.54 mm) .100" PITCH • SSW SERIES

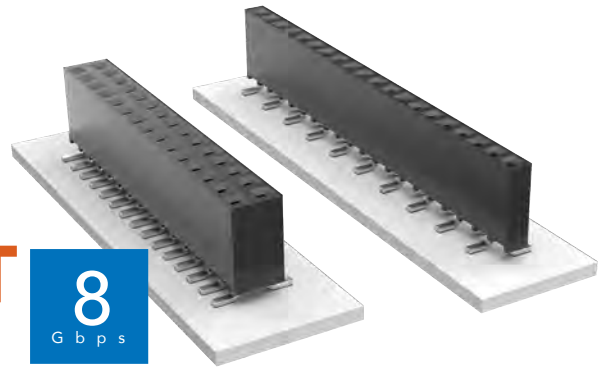

SSW

Mates:

TSW, MTSW, HTSW,
HMTSW, MTLW, EW, ZW,
TSS, HTSS, ZSS, TSM,
TSSH, DW, HW

SPECIFICATIONS

Insulator Material:

Black LCP

Contact Material:

Phosphor Bronze

Plating:

Au or Sn over
50 μ" (1.27 μm) Ni

Operating Temp Range:

-55 °C to +125 °C with Gold
-55 °C to +105 °C with Tin

Current Rating (SSW/TSM):

4.7 A per pin
(2 pins powered)

Voltage Rating:

465 VAC/658 VDC

Insertion Depth:

(3.68 mm) .145" to
(6.35 mm) .250"

Max Cycles:

100 with 10 μ" (0.25 μm) Au

PROCESSING

Lead-Free Solderable:

Yes

SMT Lead Coplanarity:

(0.10 mm) .004" max

SSW	1	NO. PINS PER ROW	22	PLATING OPTION	ROW OPTION	VS	OTHER OPTION
		02 thru 36		-F = Gold flash on contact, Matte Tin on tail -L = 10 μ" (0.25 μm) Gold on contact, Matte Tin on tail -G = 20 μ" (0.51 μm) Gold on contact, Gold flash on tail	-S = Single Row -D = Double Row		-"XX" = Polarized Position -K = -S: (3.50 mm) .138" DIA, -D: (6.50 mm) .256" DIA Polyimide film Pick & Place Pad (03 positions min.) -P = Pick & Place Pad (05 positions min.) -TR = Tape & Reel (-02 thru -28) -FR = Full Reel Tape & Reel (must order max. quantity per reel; contact Samtec for quantity breaks) (-02 thru -28)

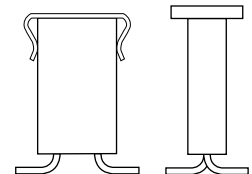
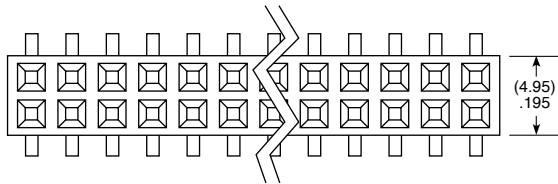
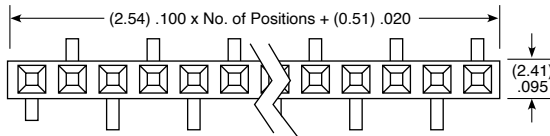

-P OPTION

ALSO AVAILABLE

Contact Samtec

Other platings

Notch option

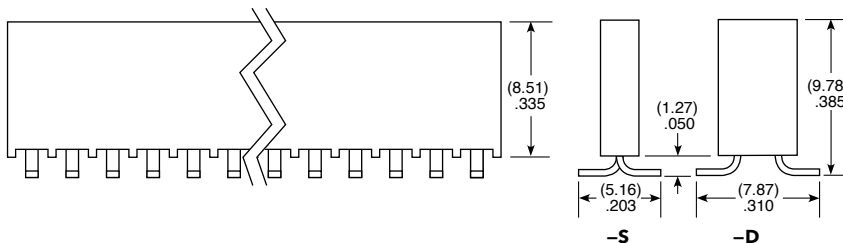

Note:

Some lengths, styles and options are non-standard, non-returnable.

TIGER CLAW™ SURFACE MOUNT SOCKET

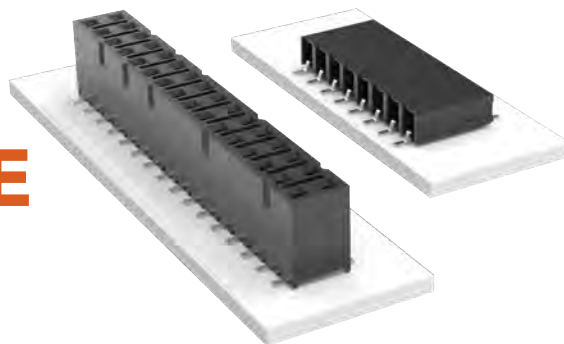

(2.54 mm) .100" PITCH • SSM SERIES

SSM

Mates:

TSW, MTSW,
TST, TSS, ZST, ZSS,
DW, EW, ZW, TSM,
HMTSW, HTSW, TSSH,
BST, HTSS, TLW, MTLW

SPECIFICATIONS

Insulator Material:

Black Liquid Crystal Polymer

Contact Material:

Phosphor Bronze

Plating:

Au or Sn over
50 μ" (1.27 μm) Ni

Operating Temp Range:

-55 °C to +125 °C with Gold

-55 °C to +105 °C with Tin

Current Rating (SSM/TSW):

5.2 A per pin

(2 pins powered)

Current Rating (SSM/TSM):

5.6 A per pin

(2 pins powered)

Voltage Rating:

405 VAC/573 VDC

Insertion Depth:

SV/DV = (4.34 mm) .171" to

(7.24 mm) .285" or pass-through

from top; (5.56 mm) .219"

plus board thickness minimum

from bottom;

SH/DH = (4.34 mm) .171" to

(6.35 mm) .250"

PROCESSING

Lead-Free Solderable:

Yes

-DH Coplanarity:

Less than 28 positions

(0.15 mm) .006" max*

More than 27 positions

(0.20 mm) .008" max*

-SH, -SV, -DV Coplanarity:

(0.15 mm) .006" max*

*(.004" stencil solution

may be available; contact

ipg@samtec.com)

ALSO AVAILABLE

Contact Samtec

Alignment pin



Notes:

Severe Environment

Testing qualified; aligns

with MIL-DTL-55302.

Visit samtec.com/set

Some sizes, styles and options are non-standard, non-returnable.

SSM	1	NO. PINS PER ROW	PLATING OPTION	ROW OPTION	OTHER OPTION
-----	---	------------------	----------------	------------	--------------

02 thru 36
(-SV, -SH, -DH)

02 thru 40
(-DV)

-F

= Gold flash on contact, Matte Tin on tail

-L

= 10 μ" (0.25 μm) Gold on contact, Matte Tin on tail

-SV

= Single Row Vertical Pin

-DV

= Double Row Vertical Pin

-SH

= Single Row Horizontal Pin

-DH

= Double Row Horizontal Pin

-“XXX”

= Polarized Position (-BE not available)

-BE

= Bottom Entry (-DV & -SV only)

-LC

= Locking Clip (-DV & -SV only) Contact Samtec for -DH & -SH

-K

= (6.50 mm) .256" DIA Polyimide film Pick & Place Pad (2 positions min.) -DV & -SV only

-M

= Metal Pick & Place Pad (5 positions min.) -DV only

-P

= Plastic Pick & Place Pad (-DV & -SV only) (6 positions min. Contact Samtec for availability on smaller positions)

-TR

= Tape & Reel (29 positions max.)

-FR

= Full Reel Tape & Reel (must order max. quantity per reel; contact Samtec for quantity breaks) (29 positions max.)

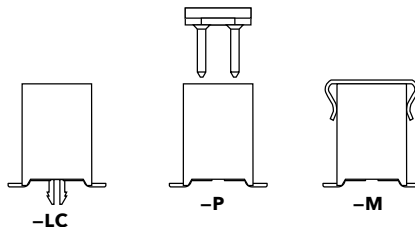
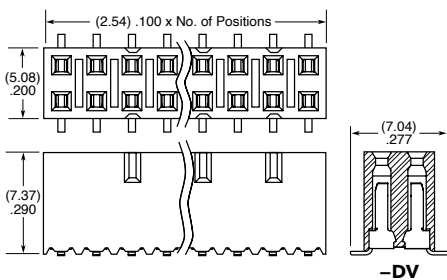
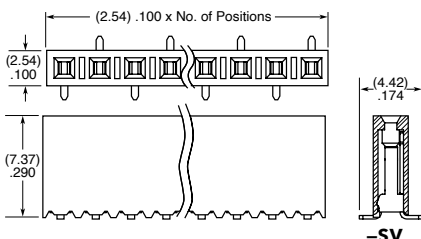
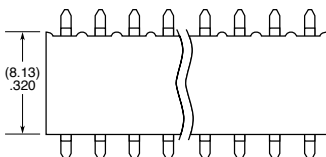
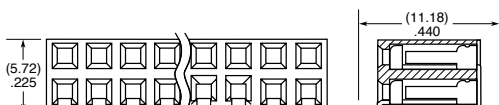
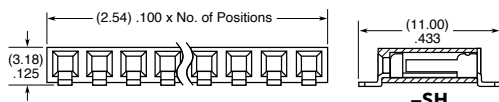

ELEVATED SOCKETS

(2.54 mm) .100" PITCH • ESW/ESQ SERIES

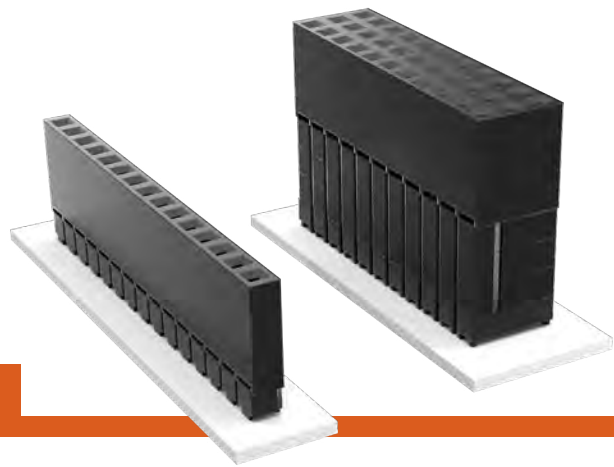

ESW/ESQ

Mates:

TSW, MTSW, EW, MTLW, TSS, ZSS, TSM, DW, ZW, HW, TSSH, HTSS

SPECIFICATIONS

Insulator Material:

Black Glass Filled Polyester

Contact Material:

Phosphor Bronze

Plating:

Au or Sn over 50 μ" (1.27 μm) Ni

Operating Temp Range:

-55 °C to +125 °C with Gold

-55 °C to +105 °C with Tin

Current Rating (ESW/TSW):

5.2 A per pin

(2 pins powered)

Current Rating (ESQ/TSW):

5.7 A per pin

(2 pins powered)

Voltage Rating:

515 VAC/728 VDC

Insertion Depth:

(3.68 mm) .145" to

(6.35 mm) .250"

Max Cycles:

100 with 10 μ" (0.25 μm) Au

PROCESSING

Lead-Free Solderable:

No, Lead Wave only

SERIES	1	NO. PINS PER ROW	LEAD STYLE	PLATING OPTION	ROW OPTION	OTHER OPTION
--------	---	------------------	------------	----------------	------------	--------------

ESW
= Solder Tail

ESQ
= Square Tail

01 thru 36

Specify **LEAD STYLE** from chart

-F
= Gold flash on contact, Matte Tin on tail

-L
= 10 μ" (0.25 μm) Gold contact, Matte Tin on tail

-G
= 20 μ" (0.51 μm) Gold contact, Gold Flash on Balance

-T
= Matte Tin (Not available with LIF contact)

-S
= Single Row

-D
= Double Row

-T
= Triple Row (ESQ only)

-LL
= Locking Lead (Two leads per strip crimped. Not available with single row 1 or 2 positions)

"XX"
= Polarized

LEAD STYLE			
STANDARD INSERTION FORCE	LOW INSERTION FORCE	A	B
-12	-37	(2.29) .090	(11.05) .435
-13	-38	(7.36) .290	
-23	-48	(4.83) .190	(13.59) .535
-33	-58	(2.29) .090	(16.13) .635
-14	-39	(12.19) .480	(11.05) .435
-24	-49	(9.65) .380	(13.59) .535
-34	-59	(7.11) .280	(16.13) .635
-44	-69	(4.57) .180	(18.67) .735

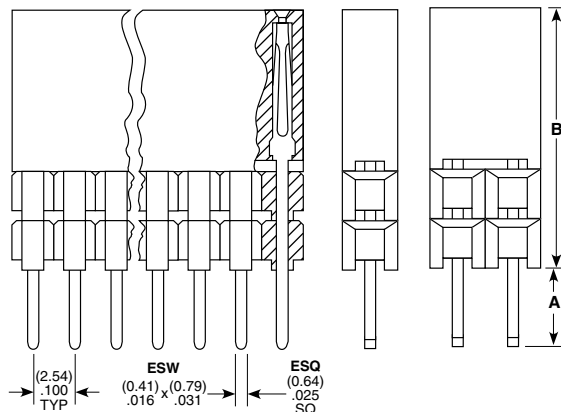
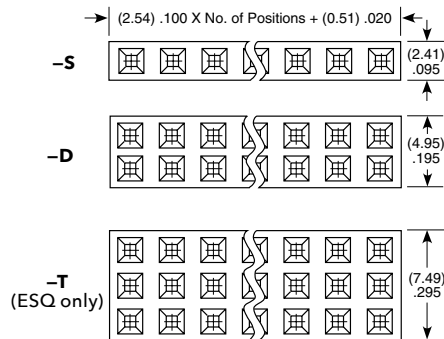

APPLICATIONS

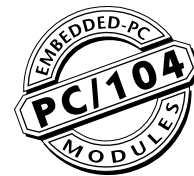

Self Nesting Sockets

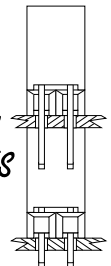

(ESQ SERIES)

PC/104™ J1/P1 "Stackthrough" Connectors	
Standard Insertion Force	ESQ-132-14-G-D
Low Insertion Force	ESQ-132-39-G-D
PC/104™ J1 "Non-Stackthrough" Connectors	
Standard Insertion Force	ESQ-132-12-G-D
Low Insertion Force	ESQ-132-37-G-D
PC/104™ J2/P2 "Stackthrough" Connectors	
Standard Insertion Force	ESQ-120-14-G-D
Low Insertion Force	ESQ-120-39-G-D

PC/104 is a trademark of the PC/104 Consortium.

ALSO AVAILABLE
Contact Samtec

Other Platings

Note:

Some lengths, styles and options are non-standard, non-returnable.

COST-EFFECTIVE RELIABLE SOCKET

(2.54 mm) .100" PITCH • HLE SERIES

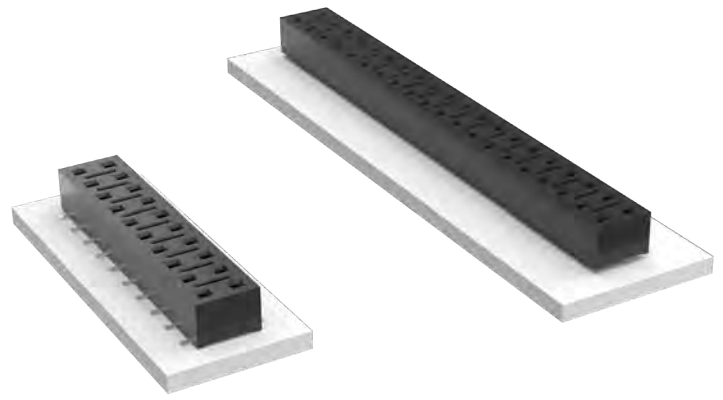

HLE
Board Mates:
TSW, MTSW, DW, EW,
ZW, TLW, TSM, MTLW, HW



02 thru 50

-F
= Gold flash on contact,
Matte Tin on tail

-L
= 10 μ" (0.25 μm)
Gold on contact,
Matte Tin on tail

Leave blank for
Surface Mount
(Requires -BE for
Bottom Entry)

-TE
= Through-hole
Top Entry

-PE
= Through-hole
Pass-through
Entry
(Requires -BE for
Bottom Entry)

-BE
= Bottom Entry
(Not available
with -TE)

-A
= Alignment Pin
(4 positions min.)
Metal or plastic at
Samtec discretion
(Not available with
-TE, -PE & -LC)

-LC
= Locking Clip
(2 positions min.)
(Not available with -A)
(Manual placement
required)

-K
= (6.50 mm)
.256" DIA
Polyimide Film
Pick & Place Pad
(3 positions min.)
Not available
with -TE or
-PE tail option

-P
= Metal Pick
& Place Pad
(3 positions min.)

-TR
= Tape & Reel
(29 positions max.)

-FR
= Full Reel
Tape & Reel
(must order max.
quantity per reel;
contact Samtec for
quantity breaks)

SPECIFICATIONS

Insulator Material:
Black Liquid Crystal Polymer
Contact Material:
BeCu
Plating:
Au or Sn over
50 μ" (1.27 μm) Ni
Operating Temp Range:
-55 °C to +125 °C
Current Rating (HLE/TSM):
4.1 A per pin
(2 pins powered)
Voltage Rating:
400 VAC/566 VDC
Insertion Depth:
(1.78 mm) .070" to
(3.43 mm) .135", pass-through,
or (2.59 mm) .102" min
plus board thickness for
bottom entry

PROCESSING

Lead-Free Solderable:
Yes
SMT Lead Coplanarity:
(0.10 mm) .004" max (02-20)
(0.15 mm) .006" max (21-50)*
*(.004" stencil solution
may be available; contact
ipg@samtec.com)

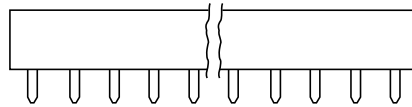
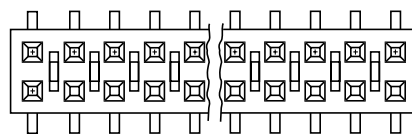
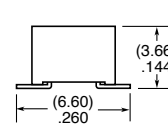
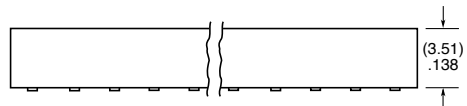
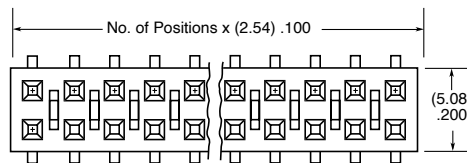

-LC

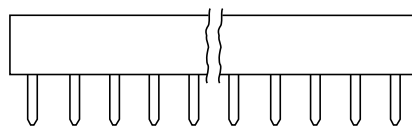
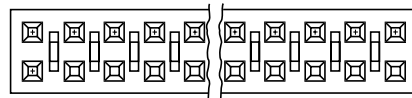
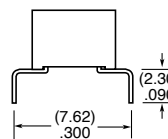

-P

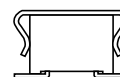
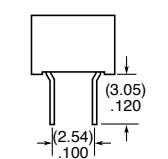

-P



-LC

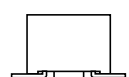

-A

ALSO AVAILABLE
Contact Samtec

Other Platings

Note:
Some lengths, styles and
options are non-standard,
non-returnable.

TIGER CLAW™ PASS-THROUGH SOCKET

(2.54 mm) .100" PITCH • BCS SERIES

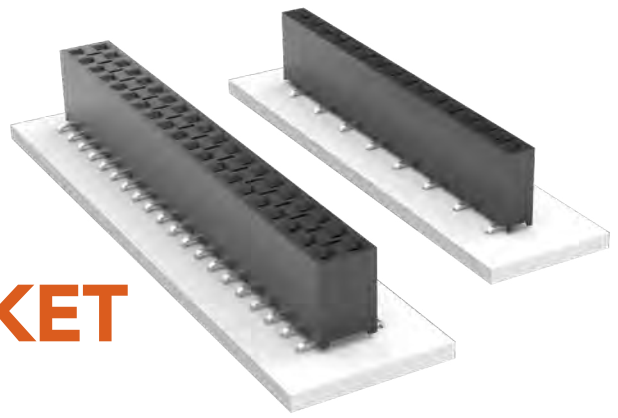

BCS

Mates:

TSW, MTSW, HTSW,
HMTSW, TSS, ZSS, DW, EW,
ZW, HW, TSM, MTLW, PHT

SPECIFICATIONS

Insulator Material:

Black Liquid Crystal Polymer

Contact Material:

Phosphor Bronze

Plating:

Au or Sn over
50 μ" (1.27 μm) Ni

Operating Temp Range:

-55 °C to +125 °C

Voltage Rating:

495 VAC/700 VDC
(-TE/-DE/-PE mated with TSM)
450 VAC/636 VDC
(-HE mated with TSW)

Insertion Depth:

(4.34 mm) .171" to
(7.24 mm) .285" from top,
(5.64 mm) .222" plus board
thickness minimum from bottom.
-HE is (4.34 mm) .171"
to (6.35 mm) .250"

PROCESSING

Lead-Free Solderable:

Yes

MATES	CURRENT RATING (PER PIN)
BCS/TSW	4.6 A
BCS/TSM	5.0 A

2 POSITIONS POWERED

ALSO AVAILABLE

Contact Samtec

Other Platings

BCS	1	NO. PINS PER ROW	PLATING OPTION	ROW OPTION	ENTRY OPTION	OTHER OPTION
-----	---	------------------	----------------	------------	--------------	--------------

01 thru 50

-F
= Gold flash on contact,
Matte Tin on tail

-L
= 10 μ" (0.25 μm)
Gold on contact,
Matte Tin on tail

-S
= Single

-D
= Double

-TE
= Top Entry

-DE
= Top Entry
(For Bottom Entry
specify -DE-BE)
Cannot be used with
plated through-holes

-PE
= Pass-through Entry
(For Bottom Entry
specify -PE-BE)

-HE
= Horizontal Entry

-"XXX"
= Polarized Position
(-BE not available)

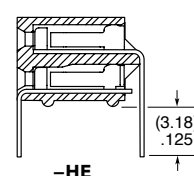
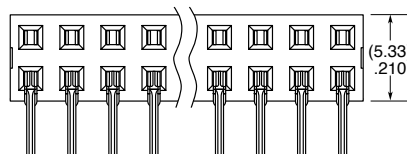
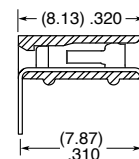
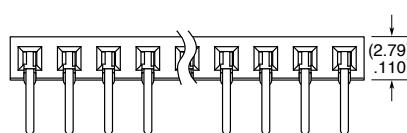
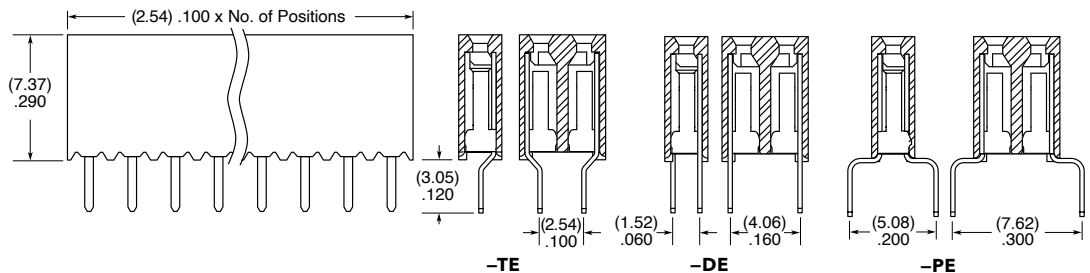
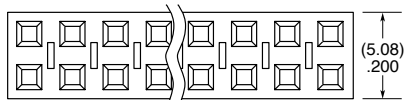
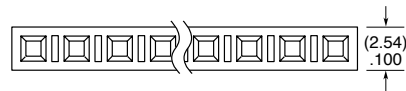

Note:

Some lengths, styles and
options are non-standard,
non-returnable.

BOTTOM MOUNT SOCKET STRIPS

(2.54 mm) .100" PITCH • BSW SERIES

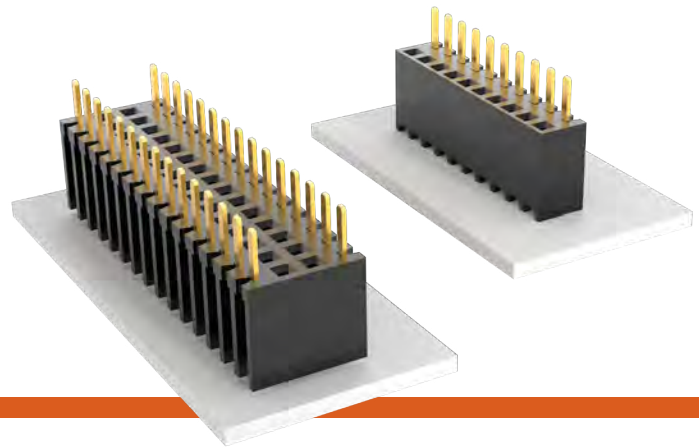

BSW

Mates:

TSW, MTSW, HTSW,
MTLW, TSM, EW, ZW,
HW, DW, PHT

FEATURES

- Bottom mount socket strips accept .025" SQ terminals.
- Ideal for soldering and plugging from the same side of the board.
- For low profile connections and high temperature soldering.

SPECIFICATIONS

Insulator Material:

Black Thermoplastic

Contact Material:

Phosphor Bronze

Plating:

Au or Sn over

50 μ" (1.27 μm) Ni

Operating Temp Range:

-55 °C to +125 °C with Gold

-55 °C to +105 °C with Tin

Insertion Depth:

(3.68 mm) .145" to

(6.35 mm) .250"

plus board thickness

PROCESSING

Lead-Free Solderable:

Wave only

ALSO AVAILABLE

Contact Samtec

Other Platings

BSW	1	NO. PINS PER ROW	LEAD STYLE	PLATING OPTION	ROW OPTION
------------	----------	-------------------------	-------------------	-----------------------	-------------------

02 thru 36

-04
= Standard Lead

-24
= Low Insertion Force

-L
= 10 μ" (0.25 μm) Gold contact, Matte Tin on tail

-G
= 20 μ" (0.51 μm) Gold contact, Gold Flash on tail

-T
= Matte Tin (Not available with Low Insertion Force)

-S
= Single Row

-D
= Double Row

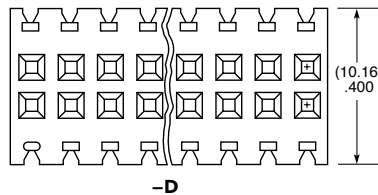
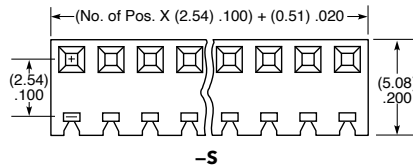

ROW OPTION	Z
-S	(4.31) .170
-D	(4.32) .170

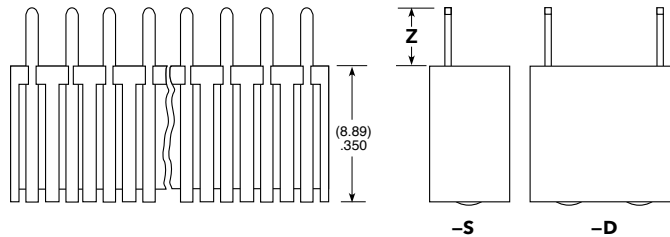

APPLICATIONS

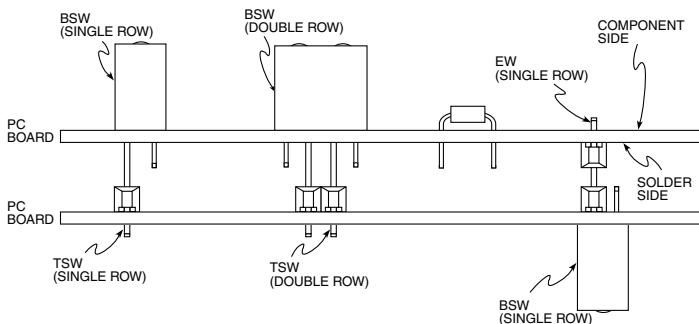

Note:

Some lengths, styles and options are non-standard, non-returnable.

LOW PROFILE SOCKET STRIPS

(2.54 mm) .100" PITCH • SLW/CES SERIES



SLW

Mates:
TLW, TSW, MTLW, MTSW,
HW, EW, ZW, HTSW,
HMTSW, TSM

CES

Mates:
TLW, TSW, MTLW,
MTSW, HW, EW, ZW,
DW, HTSW, PHT, HMTSW

SLW	-	1	NO. PINS PER ROW	-	01	PLATING OPTION	-	ROW OPTION
-----	---	---	------------------	---	----	----------------	---	------------

01 thru 50

-F

= Gold flash on contact,
Matte Tin on tail

-S

= Single Row

-L

= 10 μ " (0.25 μ m) Gold on contact,
Matte Tin on tail

-D

= Double Row

-G

= 20 μ " (0.51 μ m) Gold on contact,
Gold flash on balance

-T

= Matte Tin



SPECIFICATIONS

Insulator Material:

Black G.F. Polyester

Contact Material:

Phosphor Bronze

Plating:

Au or Sn over
50 μ " (1.27 μ m) Ni

Operating Temp Range:

-55 °C to +125 °C with Gold

-55 °C to +105 °C with Tin

Current Rating (SLW/TSW):

5.2 A per pin

(2 pins powered)

CES Current Rating (TSW/CES):

5.5 A per pin

(2 pins powered)

Voltage Rating:

SLW: 406 VAC/574 VDC

CES: 400 VAC/566 VDC

Insertion Depth:

SLW: (2.16 mm) .085" to
(2.92 mm) .115"

CES: (2.62 mm) .103" to
(4.06 mm) .160"

Lead-Free Solderable:

No, Lead Wave only

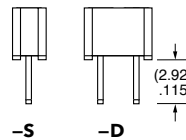
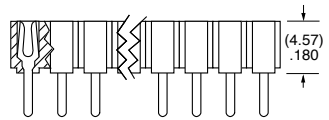
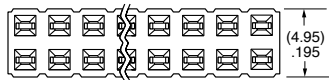
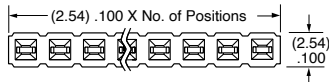

PROCESSING

Lead-Free Solderable:

No, Lead Wave only

ALSO AVAILABLE

Contact Samtec

Other Platings

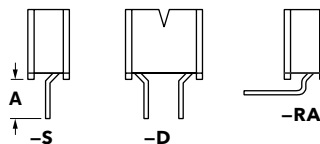
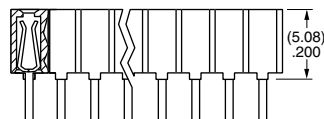
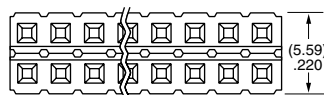
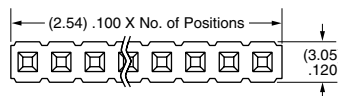

CES	-	1	NO. PINS PER ROW	-	LEAD STYLE	-	PLATING OPTION	-	ROW OPTION	-	RA OPTION
-----	---	---	------------------	---	------------	---	----------------	---	------------	---	-----------

01 thru 50

Specify
LEAD
STYLE
from
chart

-F

= Gold flash
on contact,
Matte Tin on tail

-S

= Single Row

-RA

= Right-angle
version
(Style -02 only
Single Row only)

-L

= 10 μ " (0.25 μ m)
Gold contact,
Matte Tin on tail

-D

= Double Row

-T

= Matte Tin

LEAD STYLE	A
-01	(3.25) .128
-02	(5.66) .223

Note:

Some lengths, styles and
options are non-standard,
non-returnable.

SHUNTS & JUMPERS

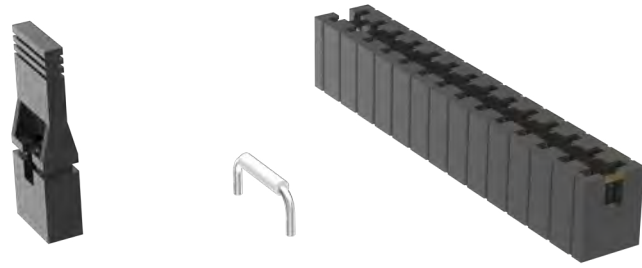

(2.54 mm) .100" PITCH • SNT/MNT/2SN/SNM/PK/JL SERIES

SNT/MNT

Mates:
TSW, HTSW, MTSW,
HMTSW, TLW, DW, EW,
ZW, HW, TSM, BST, PHT

2SN

Mates:
TMMH, TMM,
MTMM, MMT, TW,
LTMM, ZLTMM, TSH, EHT

SNM

Mates:
TMS, MTMS, DWM

SPECIFICATIONS

SNT

Insulator Material:
Glass Filled Polyester
Contact Material:
Phosphor Bronze
Current Rating (SNT/TSW):
4.3 A per pin
(1 pin powered per row)
Operating Temp Range:
-55 °C to +125 °C (Gold)
-55 °C to +105 °C (Tin)
Insertion Depth:
(4.32 mm) .170" minimum
Lead Size accepted:
(0.64 mm) .025" SQ

MNT

Same as SNT except:
Current Rating (MNT/TSM):
3.9 A per pin
(1 pin powered per row)
Working Voltage:
450 VAC

2SN

Same as SNT except:
Insertion Depth:
(2.29 mm) .090" minimum
Lead Size accepted:
(0.51 mm) .020" SQ

SNM

Same as SNT except:
Insertion Depth:
(3.43 mm) .135" minimum
Max Processing Temp:
Not recommended for IR/VP

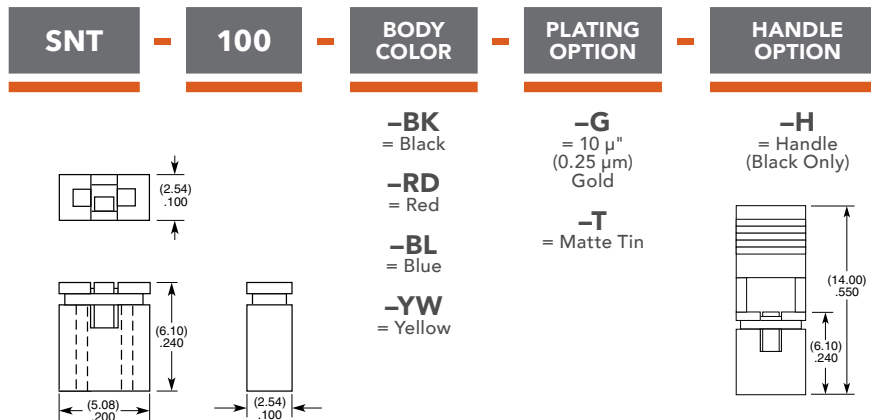

Note:
Other Gold plating options available.

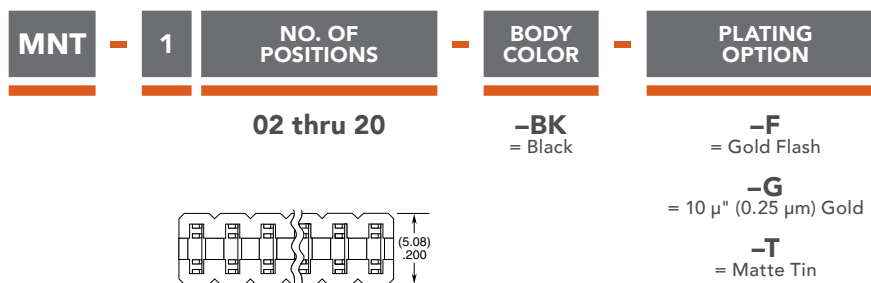

Note:
Some lengths, styles and options are non-standard, non-returnable.

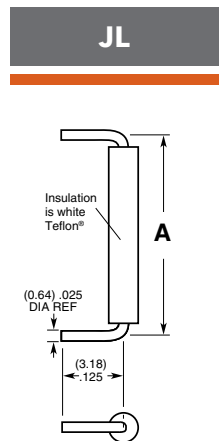
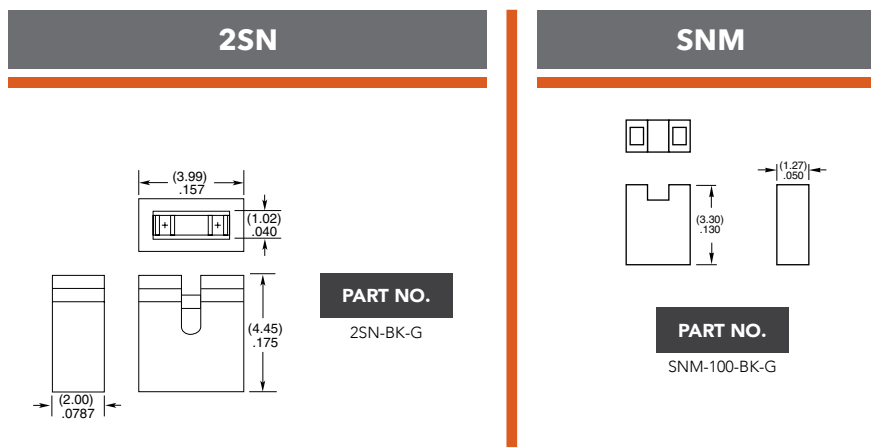

PART NO.	A
JL-100-25-T	(2.54) .100
JL-250-25-T	(6.35) .250
JL-400-25-T	(10.16) .400

Note:
For complete specifications see www.samtec.com?JL

PK

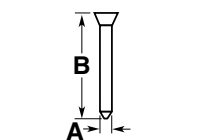

PART NO.	A	B
PK-01-06	(0.64) .025 SQ	(5.84) .230
PK-01-07	(0.51) .020 SQ	(3.18) .125

Insulator Material:
Natural Thermoplastic

Note:
Order per wheel.
6 pins per wheel.

IDC/FLAT FLEXIBLE CABLE SYSTEMS

TIGER EYE™ CONTACTS • MULTIPLE PITCHES • LOW PROFILE • SHROUDED EJECTOR TERMINALS

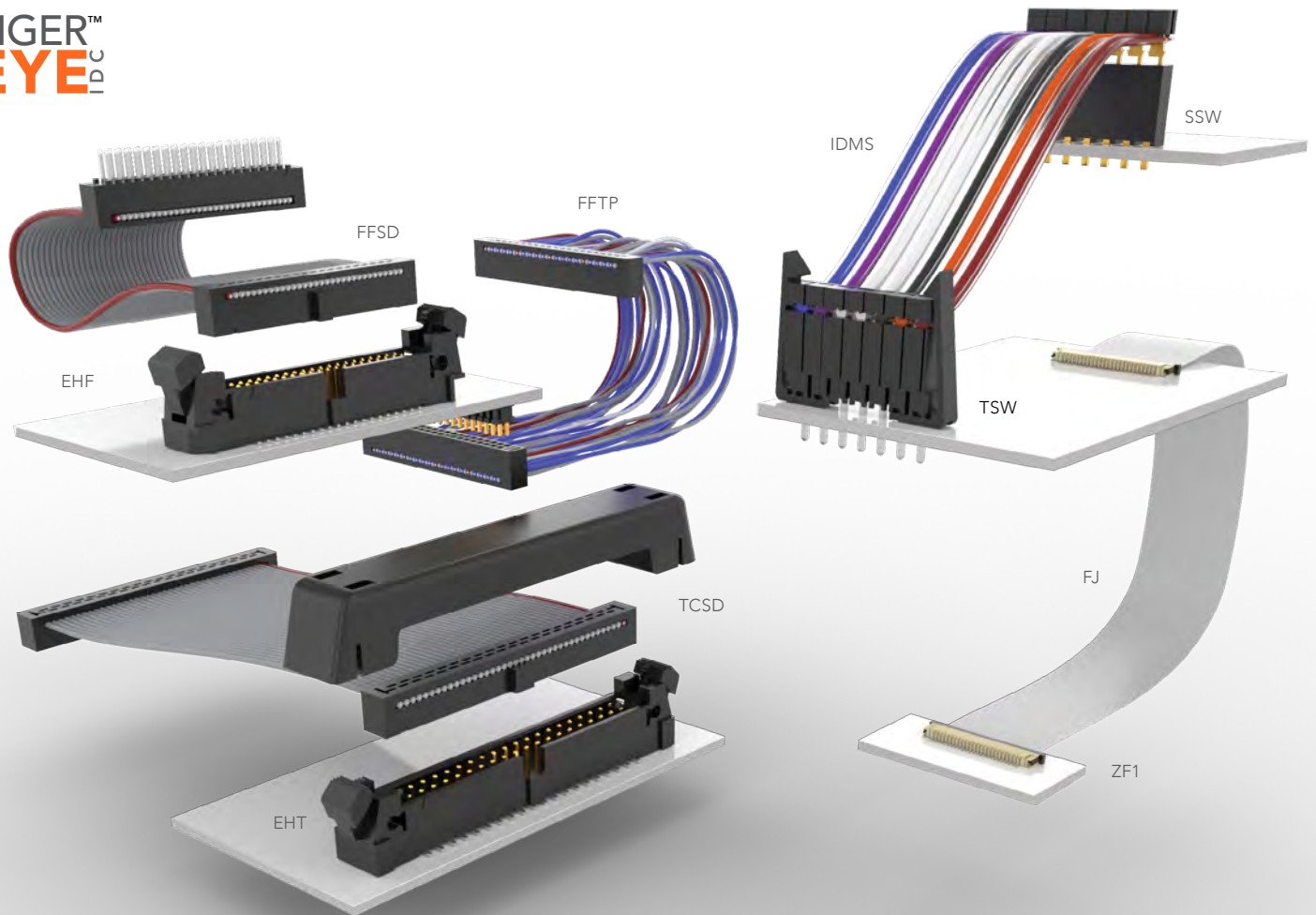

330-341

IDC ASSEMBLIES AND HEADERS

.100" (2.54 mm) Pitch (IDSX, IDMX, EJH, TST, HTST, ZST)	330-333
2.00 mm (.0787") Pitch (TCSD, TCMD, EHT, EC2, STMM, ZSTMM, ETMM)	334-337
.050" (1.27 mm) Pitch (FFSD, FFMD, FFTP, FMTP, EHF, SHF, ESHF)	338-341

342

FLEX JUMPERS

0.50 mm (.0197") Pitch FFC Jumper & Sockets (FJH, ZF5S)	342
---	-----

SLIM BODY FLAT RIBBON IDC CABLES

(2.54 mm) .100" PITCH • IDSS/IDSD/IDMS/IDMD SERIES



IDSS/IDMS/IDMD

Mates:

TSW, MTSW, TSM, EJH, PHT, HMTSW, HTSW, HW, DW, EW, ZW, MTLW

IDSD

Mates:

TST, HTST, ZST, EJH

SERIES	ROW OPTION	NO. PINS PER ROW
IDM = Standard Tail Male Plug	S = Single	-02 thru -32 = IDMS/IDMD
IDS = Socket	D = Double (Color coded cable Not available for 31 thru 36 pins/row. See -G option.)	-02 thru -36 = IDSS/IDSD

SPECIFICATIONS

Insulator Material:

Black Glass Filled Polyester

Contact (IDSS/IDSD):

BeCu

Terminal (IDMS/IDMD):

Phosphor Bronze

Plating:

Au over 50 μ" (1.27 μm) Ni or Sn over 100 μ" (2.54 μm) Cu or 50 μ" (1.27 μm) Ni

Wire:

28 AWG 7/36 stranded
Tinned Copper

Operating Temp Range:

-20 °C to +105 °C

(Rainbow Cable)

-40 °C to +105 °C

(Gray Cable)

Current Rating (IDMD):

3 A per pin
(2 pins powered)

Voltage Rating:

425 VAC/600 VDC

Lead Size Range:

(0.56 mm) .022" SQ to

(0.71 mm) .028" SQ

Lead Insertion Depth:

(5.59 mm) .220" to

(6.22 mm) .245"

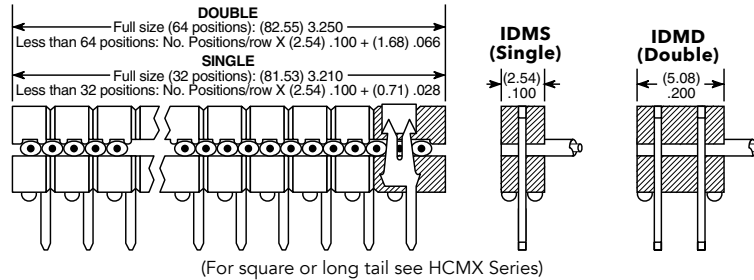

IDMX shown

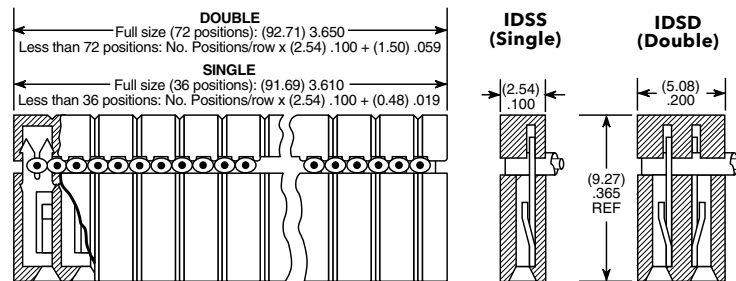

IDSX shown

ALSO AVAILABLE

Molded-To-Position IDC Assemblies

Low Profile

Skinny side locks

Dual beam contacts

Single and double row

(6.35mm) .025" square and

(5.84mm) .230" length tail available

Visit samtec.com?HCSD, samtec.com?HCSS,

samtec.com?HCMD or samtec.com?HCMS

for more detailed information.

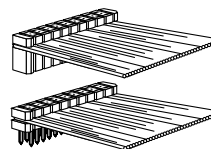
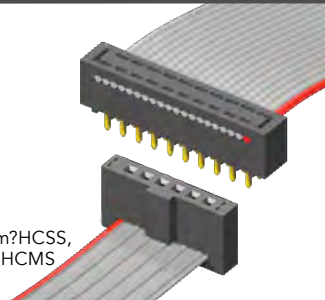

Single End (-S)

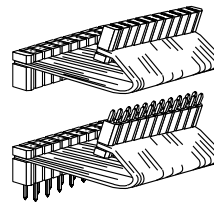

Double End (-D)

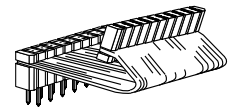

Transfer End (-T)

Note:

This Series is non-standard, non-returnable.



END ASSEMBLY

ASSEMBLED LENGTH

OPTION

-S
= Single End
(Socket or Male Plug on one end)

-D
= Double End
(Socket or Male Plug on each end)

-T
= Transfer End
(Male Plug on one end with socket on other.
Begin part number with IDM)

-“XX.XX”
= Assembled Length

-T
= Tin Plating
(Both Ends)

-C
= Tin IDM,
10 μ" (0.25 μm) Gold IDS
(-T End Assembly Required)

-A
= Tin IDS,
10 μ" (0.25 μm) Gold IDM
(-T End Assembly Required)

-P “XX”
= Polarized
Specify “XX” as position.
For Double the same position
will be polarized on both ends.
(Not available on IDM unless transfer,
then only the socket is polarized.)

-G
= Gray Cable
Specify -G for Gray cable.
Gray cable has one red edge.
IDSS and IDMS uses
(2.54 mm) .100" centerline cable.
IDSD and IDMD uses
(1.27 mm) .050" centerline cable.
Cable is 28 AWG 7/36 copper wire.
Standard cable is same as
above except color

-ST “X”
= Stripped & Tinned
(Specify Suffix from table)
(All dimensions are ± 1/16" (1.59 mm)
(Not available in 28 positions and higher)

-B “XX”
= Breakout
(Specify “XX” as number of
conductors to be broken out)
(Breakout starts with Number 1 lead
indicated by brown wire or red stripe.
Shown on top side)

-RW
= Reverse Wiring
(#1 wire opposite position #1)

-S “XX”
= Daisy Chain, Single
(When mating double row
connector with two single row
connectors, the outer most single will
be connected to Conductor #1 and
the inside single to Conductor #2)

-D “XX”
= Daisy Chain, Double

-W “XX”
= Wiring Reverse Daisy Chain, Single
(Same as -S “XX” except outer strip
connected to Conductor #2 and inside
strip connected to Conductor #1)

-R
= Reversed

-M
= Middle Reversed
(Requires -SXX, -WXX or -DXX)

-O
= Outside Reversed
(Requires -SXX, -WXX or -DXX)

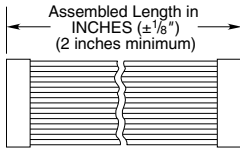

Assembled Length (-“XX.XX”)

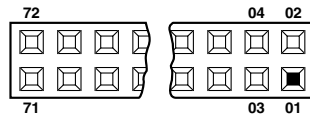

Polarized (-P “XX”)

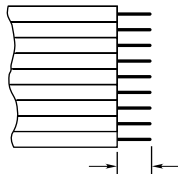

-ST8	1/8" (3.18)
-ST4	1/4" (6.35)
-ST2	1/2" (12.70)
-ST3	3/8" (19.53)

Stripped & Tinned (-ST “X”)

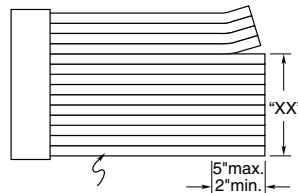

Breakout starts with
Number 1 lead indicated
by brown wire or red stripe.
Shown on top side.

Breakout (-B “X”)

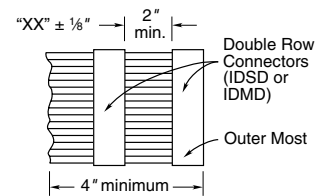

Daisy Chain Single (-S “XX”)

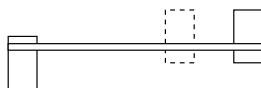

Reversed (-R)

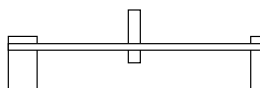

Middle Reversed (-M)

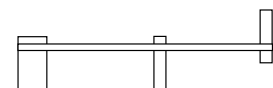

Outside Reversed (-O)

SHROUDED IDC EJECTOR HEADERS

(2.54 mm) .100" PITCH • EJH SERIES

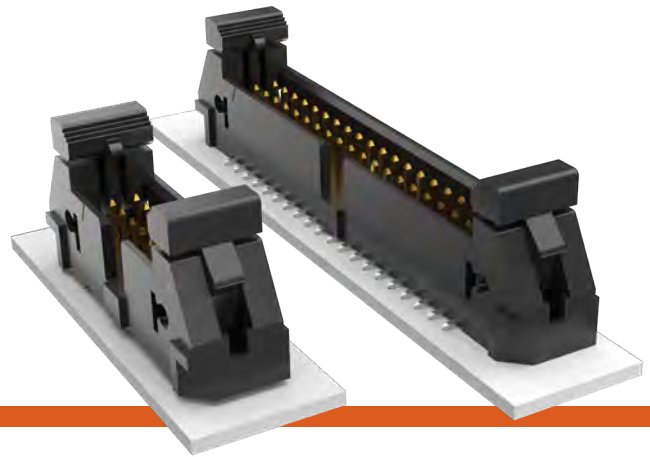

EJH

Mates:

IDSD (EJH-01 Required),
HCSD (EJH-02 Required)

SPECIFICATIONS

Insulator Material:

-01=Black LCP
-02=Natural LCP

Terminal Material:

Phosphor Bronze

Plating:

Sn or Au over 50 μ" (1.27 μm) Ni

Operating Temp Range:

-55 °C to +125 °C

PROCESSING

Lead-Free Solderable:

Yes

SMT Lead Coplanarity:

(0.10 mm) .004" max

ALSO AVAILABLE

Contact Samtec

Other sizes

Other platings

EJH	1	NO. PINS PER ROW	LEAD STYLE	PLATING OPTION	D	TAIL OPTION	OTHER OPTION
-----	---	------------------	------------	----------------	---	-------------	--------------

05, 07,
08, 10,
13, 15,
17, 20, 25
(Standard sizes)

-01
= Standard
(Mates to IDSD)

-02
= Extended
(Mates to HCSD)

-F
= Gold flash
on post,
Matte Tin
on tail

-L
= 10 μ"
(0.25 μm)
Gold on post,
Matte Tin
on tail

-SM
= Surface
Mount

-TH
= Through-hole

-RA
= Right-angle

-“XX”
= Polarized
Position

-LC
= Locking Clip
(-SM only)
(Manual
placement
required)

-K
= .475"
(12.00 mm)
DIA
Polyimide
Film Pick &
Place Pad
(-SM only)

-P
= Pick &
Place Pad
(-SM only)

-TR
= Tape &
Reel
(-SM only)
(25 position
not available)

-FR
= Full Reel
Tape & Reel
(must order
max. quantity
per reel;
contact
Samtec for
quantity
breaks)
(-SM only)
(25 position
not available)

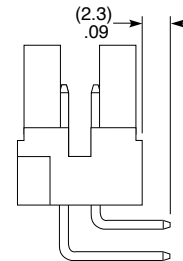
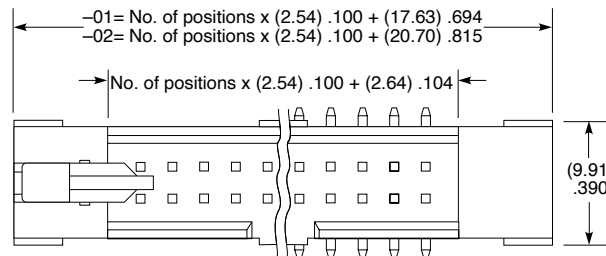

-RA OPTION

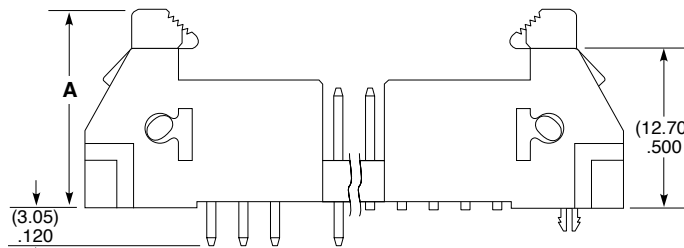

-LC OPTION

-TH OPTION

-SM OPTION

(Latch removed for clarity)

LEAD STYLE	A
-01	(16.88) .665
-02	(17.39) .685

Note:

Some lengths, styles and options are non-standard, non-returnable.

SHROUDED .025" SQ POST IDC HEADERS

(2.54 mm) .100" PITCH • TST/HTST/ZST SERIES

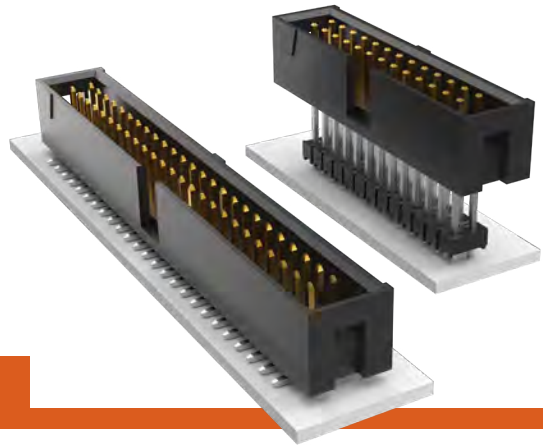

TST/HTST/ZST

Mates:
IDSD, HCSD

SPECIFICATIONS

Insulator Material:

TST, ZST=Black Glass Filled Polyester
HTST=Natural LCP

Terminal Material:

Phosphor Bronze

Plating:

Au or Sn over
50 μ" (1.27 μm) Ni

Operating Temp Range:

-55 °C to +125 °C with Gold
-55 °C to +105 °C with Tin

Current Rating:

3.4 A per pin
(2 pins powered)

Voltage Rating:

425 VAC/600 VDC

PROCESSING

Lead-Free Solderable:

HTST=Yes

TST, ZST= No, Lead Wave only

SMT Lead Coplanarity:

(0.10 mm) .004" max (05-15)
(0.15 mm) .006" max (17-36)*
*(.004" stencil solution may be available; contact ipg@samtec.com)

SERIES	1	NO. PINS PER ROW	05, 07, 08, 10, 12, 13, 15, 17, 20, 25, 32, 36 (Standard sizes)	LEAD STYLE	Specify LEAD STYLE from chart	PLATING OPTION	-F = Gold flash on post, Matte Tin on tail (Not available on -DV) -L = 10 μ" (0.25 μm) Gold on post, Matte Tin on tail -T = Matte Tin	ROW OPTION	-D = Double Row Through-hole (lead style -01, -02 & -03 only) -DV = Double Row Surface Mount (lead style -01 only) (HTST only) -D-RA = Double Row Right-angle (lead style -04 & -05 only)	OTHER OPTION	Surface Mount (lead style -01 only) (HTST only) -P = Pick & Place Pad -TR = Tape & Reel -FR = Full Reel Tape & Reel (must order max. quantity per reel; contact Samtec for quantity breaks)
--------	---	------------------	---	------------	-------------------------------	----------------	---	------------	---	--------------	--

LEAD STYLE	THROUGH-HOLE (A)
-01	(2.92) .115
-02	(4.19) .165
-03	(14.35) .565

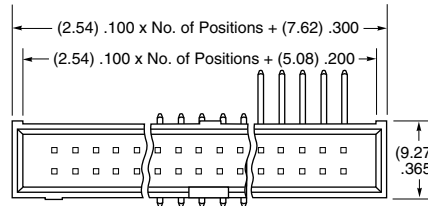

-D -DV -D-RA

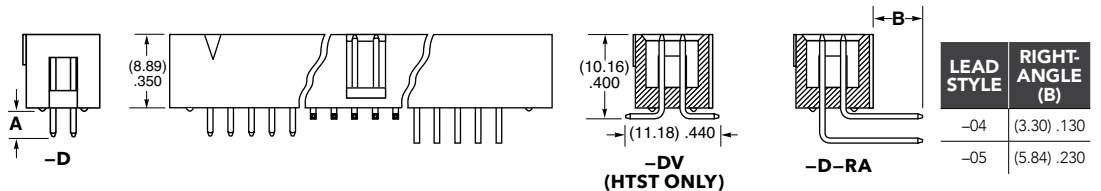

ZST	1	NO. PINS PER ROW	05, 07, 08, 10, 12, 13, 15, 17, 20, 25, 32, 36 (Standard sizes)	LEAD STYLE	Specify LEAD STYLE from chart	PLATING OPTION	-F = Gold flash on post, Matte Tin on tail -L = 10 μ" (0.25 μm) Gold on post, Matte Tin on tail -T = Matte Tin	D	-"XXXX" = Body Height
-----	---	------------------	---	------------	-------------------------------	----------------	--	---	--------------------------

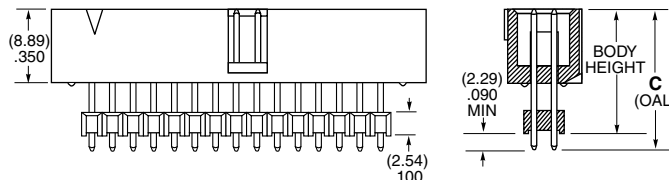
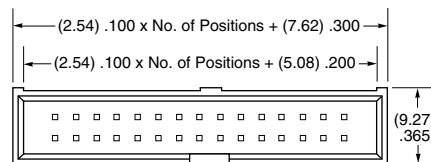

LEAD STYLE	C (OAL)	MAX BODY HEIGHT
-01	(16.00) .630	(13.72) .540
-02	(18.54) .730	(16.26) .640
-03	(21.08) .830	(18.80) .740
-04	(23.62) .930	(21.34) .840
-05	(26.16) 1.030	(23.88) .940
-06	(28.70) 1.130	(26.42) 1.040
-07	(31.24) 1.230	(28.96) 1.140
-08	(33.78) 1.330	(31.50) 1.240
-09	(36.32) 1.430	34.04) 1.340

Note:

For added mechanical stability, Samtec recommends mechanical board spacers be used in applications with gold or selective gold plated connectors. Contact ipg@samtec.com for more information.

ALSO AVAILABLE Contact Samtec

Other platings & sizes
Alignment Pins
Single Row
Locking Leads
Polarized

Note:

Some lengths, styles and options are non-standard, non-returnable. ZST is non-standard, non-returnable.

TIGER EYE™ IDC SOCKET CABLE

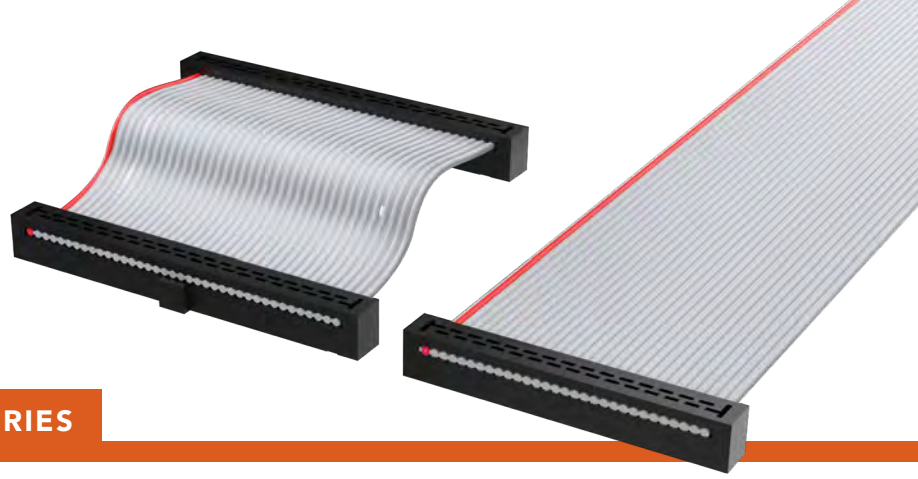

(2.00 mm) .0787" PITCH • TCSD SERIES

TCSD

Mates:

TMM, TMMH, STMM,
MMT, TW, MTMM, EHT,
ETMM (-SR), ZSTMM

SPECIFICATIONS

Insulator Material:

Black Glass Filled Polyester

Contact:

BeCu

Plating:

Au or Sn over

50 μ" (1.27 μm) Ni

Wire:

28 AWG 7/36 Stranded,

Tinned, Copper with

Gray PVC Insulator

Operating Temp Range:

-40 °C to +105 °C

Current Rating (TCSD/STMM):

2.8 A per pin

(2 pins powered)

Voltage Rating:

300 VAC/424 VDC

Lead Size Accepted:

(0.48 mm) .019" to

(0.53 mm) .021"

Insertion Depth:

(2.87 mm) .113" to

(3.17 mm) .125"

ALSO AVAILABLE

Contact Samtec

Other sizes

Other platings

POLARIZING KEY

Specify PK-01-07 for polarizing key

(Available in wheels of six each).

Also polarizes SMM Series socket strips.

SERIES	NO. PINS PER ROW	END OPTION	OVERALL LENGTH	01	PLATING OPTION	N	OTHER OPTION
TCSD = Socket Strip	-04, -05, -07, -08, -10, -12, -13, -15, -17, -20, -22, -25 (Standard sizes)	-S = Single End -D = Double End	- "XX.XX" = Assembled Length		-F = Gold flash on contact	-N = Notch Polarization	-P "XX" = Position Polarization (Specify "XX" as position number. Same position will be polarized on both ends) -B "XX" = Breakout (Specify "XX" as number of conductors to be broken out) -RW = Reverse Wiring (Blue or black wire opposite position #1) -D "XX" = Daisy Chain -SR = Strain Relief (Not available with -O, -M, -R, -DXX or -BXX) -R = Reversed -M = Middle Reversed (Requires -DXX) -O = Outside Reversed (Requires -DXX)

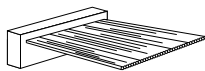
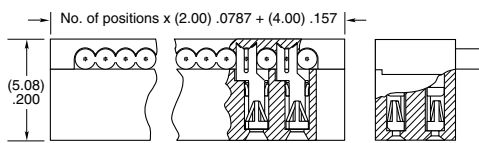
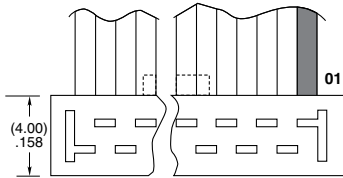

Single End (-S)

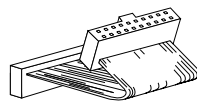

Double End (-D)

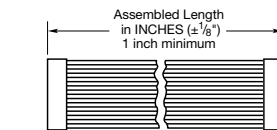

Assembled Length (-"XX.XX")

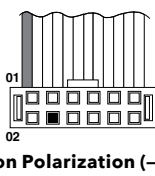

Position Polarization (-P "XX")

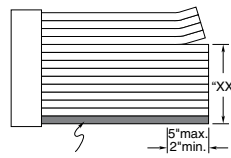

Breakout starts with Number 1 lead indicated by brown wire or red stripe. Shown on top side.

Breakout (-B "XX")

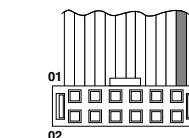

Reverse Wiring (-RW)

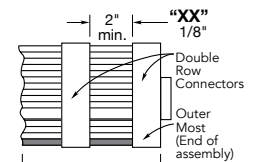

Daisy Chain (-D "XX")

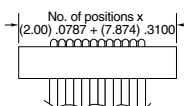

Strain Relief (-SR)



Reversed (-R)

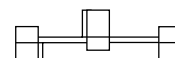

Middle Reversed (-M)

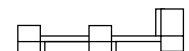

Outside Reversed (-O)

Note:

TCSD Series assemblies are non-standard, non-returnable.

HIGH-RELIABILITY IDC HEADER CABLE

(2.00 mm) .0787" PITCH • TCMD SERIES

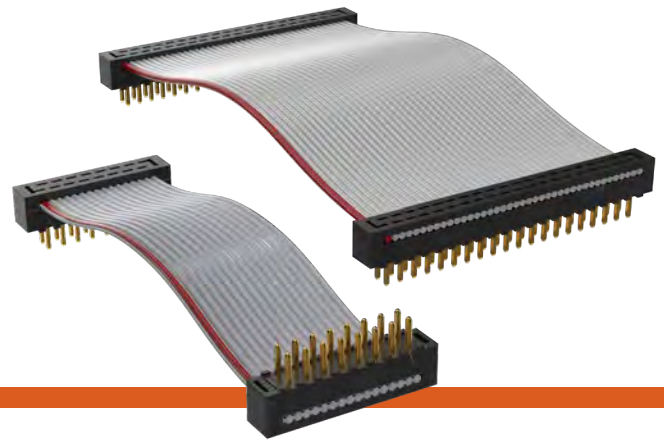

TCMD

Mates:

SMM*, MMS*, ESQT,
PTF, SQT, SQW, TLE

SPECIFICATIONS

Insulator Material:

Black Glass Filled Polyester

Terminal:

Phosphor Bronze

Plating:

Au or Sn over
50 μ" (1.27 μm) Ni

Wire:

28 AWG 7/36 Stranded, Tinned,
Copper with
Gray PVC Insulator

Operating Temp Range:

-40 °C to +105 °C

Current Rating:

2.6 A per pin
(2 pins powered)

Voltage Rating:

300 VAC/424 VDC

ALSO AVAILABLE

Contact Samtec

Other sizes



Single End (-S)

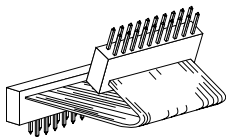

Double End (-D)

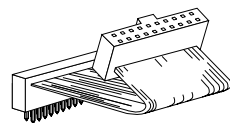

Transfer End (-T)

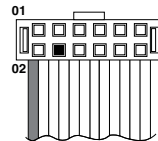

Position Polarization (-P "XX")

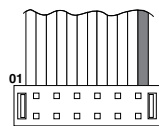

Reverse Wiring (-RW)

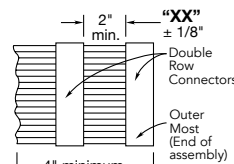

Daisy Chain (-D "XX")

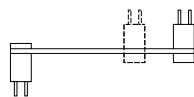

Reversed (-R)

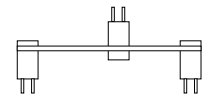

Middle Reversed (-M)

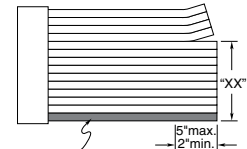

Breakout starts with Number 1 lead indicated by brown wire or red stripe. Shown on top side.

Breakout (-B "XX")

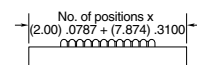

Strain Relief (-SR)

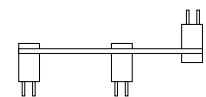

Outside Reversed (-O)

SERIES	NO. PINS PER ROW	END OPTION	OVERALL LENGTH	01	TRANSFER OPTION	OTHER OPTION
--------	------------------	------------	----------------	----	-----------------	--------------

TCMD
= Terminal Strip

-04, -05, -07
-08, -10, -12,
-13, -15, -17,
-20, -22, -25
(Standard sizes)

-S
= Single End

-D
= Double End

-T
= Transfer End

-"XX.XX"
= Assembled Length

Leave blank for
-S and -D
End Options.
For -T End
Option Specify
"-N"
(Socket has notch
polarization)

-P "XX"
= Position
Polarization
(Specify "XX" as
position number.
Requires Transfer
End. Only Socket
is polarized.)

-B "XX"
= Breakout
(Specify "XX"
as number of
conductors to
be broken out)

-RW
= Reverse Wiring
(Blue or black
wire opposite
position #1)

-D "XX"
= Daisy Chain

-SR
= Strain Relief
(Not available
with -O, -M, -R,
-DXX or -BXX)

-R
= Reversed

-M
= Middle Reversed
(Requires -DXX)

-O
= Outside
Reversed
(Requires -DXX)

***Note:**
Standard TCMD callout
will not mate with SMM, MMS.
Must use gold plated callouts.
(See drawing on web.)
When mated with a socket,
Wire 1 mates with Pin 2;
Wire 2 mates with Pin 1, etc.

Note:
TCMD Series assemblies are
non-standard, non-returnable.

SHROUDED IDC HEADERS

(2.00 mm) .0787" PITCH • ETMM/EHT/EC2 SERIES

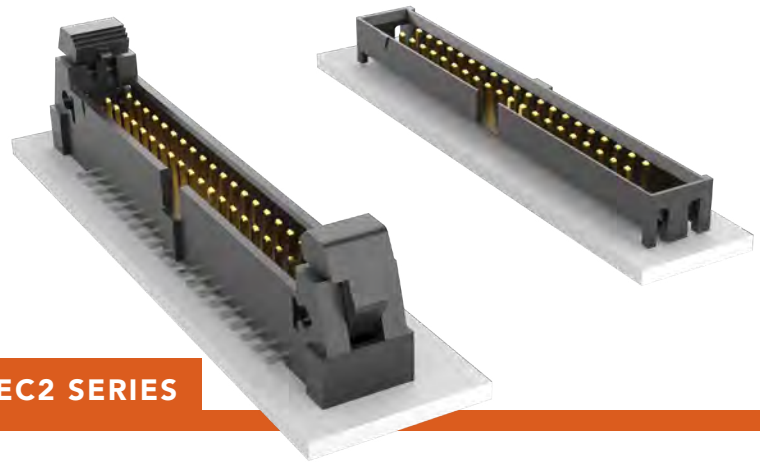

ETMM

Mates:
TCSD, TCMD

EHT

Mates:
TCSD

SPECIFICATIONS

Insulator Material:
Black Liquid Crystal Polymer
Terminal Material:
Phosphor Bronze
Plating:
Sn or Au over
50 μm (1.27 μm) Ni
Operating Temp Range:
-55 °C to +125 °C

PROCESSING

Lead-Free Solderable:
Yes
SMT Lead Coplanarity:
EHT = (0.10 mm) .004" max
ETMM = (0.13 mm) .005" max*
*(.004" stencil solution
may be available; contact
ipg@samtec.com)

TYPE STRIP	1	NO. PINS PER ROW	02	PLATING OPTION	D	TAIL OPTION	OTHER OPTION
ETMM		05, 08, 10, 12, 13, 15, 17, 20, 22, 25 (Standard sizes)		-F = Gold Flash on post, Matte Tin on tail -L = 10 μm (0.25 μm) Gold on post, Matte Tin on tail		-TH = Through-hole -RA = Right-angle -SM = Surface Mount	-“XX” = Polarized Position -LC = Locking Clip (N/A with -RA) (Manual placement required) -K = (7.50 mm) .295" DIA Polyimide Film Pick & Place Pad (-SM only) -TR = Tape & Reel (-SM only) -FR = Full Reel Tape & Reel (must order max. quantity per reel; contact Samtec for quantity breaks) (-SM only)

EHT	1	NO. PINS PER ROW	01	PLATING OPTION	D	TAIL OPTION	OTHER OPTION
EJECTOR HEADER CAP (Locks TCSD cable to EHT header)		05, 08, 10, 12, 13, 15, 17, 20, 22, 25		-F = Gold flash on post, Matte Tin on tail -L = 10 μm (0.25 μm) Gold on post, Matte Tin on tail		Leave blank for Through-hole -RA = Right-angle -SM = Surface Mount	-“XX” = Polarized Position -SR = Strain Relief (Leave Blank for no strain relief) -LC = Locking Clip (-SM only) (Manual placement required) -K = (7.50 mm) .295" DIA Polyimide Film Pick & Place Pad (-SM only) -P = Pick & Place Pad (-SM only) -TR = Tape & Reel (-SM only) -FR = Full Reel Tape & Reel (must order max. quantity per reel; contact Samtec for quantity breaks) (-SM only)

EJECTOR HEADER CAP
(Locks TCSD cable to EHT header)

No. of positions x (2.00) .0787 + (19.89) .783

EC2 - NO. PINS PER ROW

05, 08, 10, 12, 13,
15, 17, 20, 22, 25

Note:
Some lengths, styles and
options are non-standard,
non-returnable.

SHROUDED IDC HEADER & STACKER

(2.00 mm) .0787" PITCH • STMM/ZSTMM SERIES

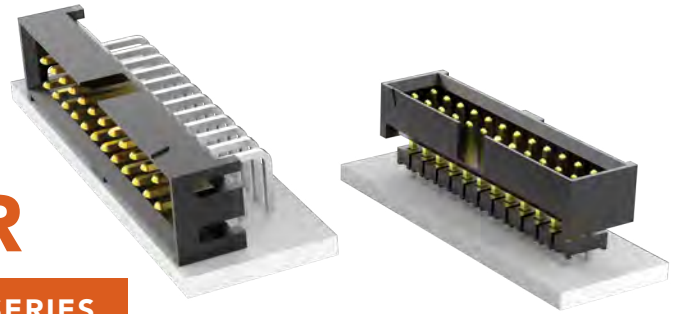

STMM/ZSTMM

Mates:
TCSD (except -SR)

SPECIFICATIONS

Insulator Material:
Black Liquid Crystal Polymer
Terminal Material:
Phosphor Bronze
Plating:
Sn or Au over
50 μ" (1.27 μm) Ni
Operating Temp Range:
-55 °C to +105 °C with Tin;
-55 °C to +125 °C with Gold
Current Rating (STMM/TCSD):
2.8 A per pin
(2 pins powered)
Voltage Rating:
300 VAC/424 VDC

PROCESSING

Lead-Free Solderable:
Yes
SMT Lead Coplanarity:
(0.10 mm) .004" max

STMM	1	NO. PINS PER ROW	02	PLATING OPTION	D	TAIL OPTION	OTHER OPTION
		04, 05, 06, 07, 08, 10, 12, 13, 14, 15, 17, 20, 22, 25 (Standard sizes)		-F = Gold flash on post, Matte Tin on tail -L = 10 μ" (0.25 μm) Gold on post, Matte Tin on tail -T = Matte Tin		Leave blank for Through-hole -RA = Right-angle -SM = Surface Mount	- "XX" = Polarized Position -LC = Locking Clip (-SM only) (Manual placement required) -K = (7.50 mm) .295" DIA Film Pick & Place Pad (-SM only) -TR = Tape & Reel (-SM only) -FR = Full Reel Tape & Reel (must order max. quantity per reel; contact Samtec for quantity breaks) (-SM only)

ZSTMM	1	NO. PINS PER ROW	LEAD STYLE	PLATING OPTION	D	BODY HEIGHT	OTHER OPTION
		04, 05, 06, 07, 08, 10, 12, 13, 14, 15, 17, 20, 22, 25 (Standard sizes)	Specify LEAD STYLE from chart	-F = Gold flash on post, Matte Tin on tail -L = 10 μ" (0.25 μm) Gold on post, Matte Tin on tail -T = Matte Tin		- "XXX" = Body Height	- "XX" = Polarized Position

ALSO AVAILABLE

Contact Samtec

Other sizes
Other platings

Notes:
For added mechanical stability, Samtec recommends mechanical board spacers be used in applications with gold or selective gold plated connectors. Contact ipg@samtec.com for more information.

This Series is non-standard, non-returnable.

LEAD STYLE	A (OAL)	MAX BODY HEIGHT
-75	(9.58) 0.377	(7.42) 0.292
-62	(10.08) 0.397	(7.92) 0.312
-65	(10.49) 0.413	(8.33) 0.328
-73	(12.09) 0.476	(9.93) 0.391
-63	(14.10) 0.555	(11.94) 0.470
-66	(15.09) 0.594	(12.93) 0.509
-69	(15.60) 0.614	(13.44) 0.529
-74	(17.09) 0.673	(14.94) 0.588
-70	(17.60) 0.693	(15.44) 0.608
-71	(21.08) 0.830	(18.92) 0.745
-72	(21.62) 0.851	(19.46) 0.766

TIGER EYE™ FLAT IDC WIRE CABLES

(1.27 mm) .050" PITCH • FFSD SERIES

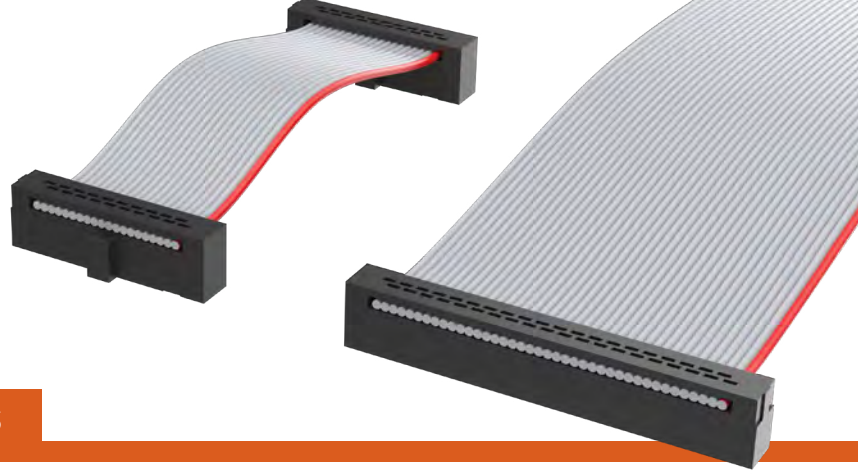

FFSD

Mates:

FTS, FTSH, EHF,
SHF, ESHF

SPECIFICATIONS

Insulator Material:

PBT

Contact:

BeCu

Plating:

10 μ" (0.25 μm) Au over 50 μ"
(1.27 μm) Ni on contact area;
Sn over 50 μ" (1.27 μm) Ni
on balance

Wire:

30 AWG

Operating Temp Range:

-40 °C to +105 °C

Current Rating (FFSD/FTSH):

2.7 A per pin
(2 pins powered)

Voltage Rating:

160 VAC/226 VDC

Lead Size Accepted:

(0.41 mm) .016" SQ

Insertion Depth:

(2.64 mm) .104" to
(3.17 mm) .125"

ALSO AVAILABLE
Contact Samtec

Other Sizes

SERIES	NO. PINS PER ROW	END OPTION	OVERALL LENGTH	01	N	OTHER OPTION
--------	------------------	------------	----------------	----	---	--------------

FFSD
= Socket Strip

-04, -05, -06, -08, -10, -11, -12, -13, -15, -17, -20, -25
(Standard sizes)

-S
= Single End
-D
= Double End

-"XX.XX"
= Assembled Length

-N
= Notch Polarization
(Notch option not available with -04 position)

-RW
= Reverse Wiring
(Red wire opposite position #1)

-D "XX"
= Daisy Chain

-SR
= Strain Relief
(Mates only with ESHF Series)
(Not available with -O, -M, -R or -DXX)

-R
= Reversed

-M
= Middle Reversed
(Requires -DXX)

-O
= Outside Reversed
(Requires -DXX)

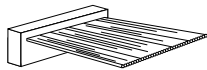
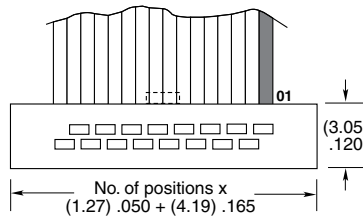

Single End (-S)

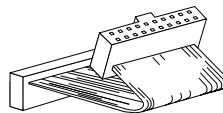

Double End (-D)

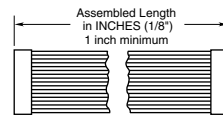

Assembled Length (-"XX.XX")

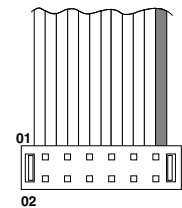

Reverse Wiring (-RW)

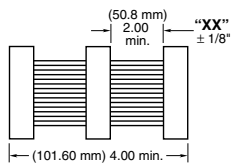

Daisy Chain (-D "XX")

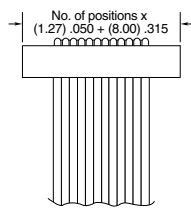

Strain Relief (-SR)

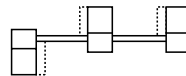

Reversed (-R)

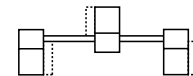

Middle Reversed (-M)

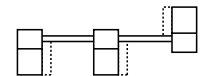

Outside Reversed (-O)

Note:
This Series is non-standard,
non-returnable.

TIGER EYE™ FLAT IDC WIRE CABLES

(1.27 mm) .050" PITCH • FFMD SERIES

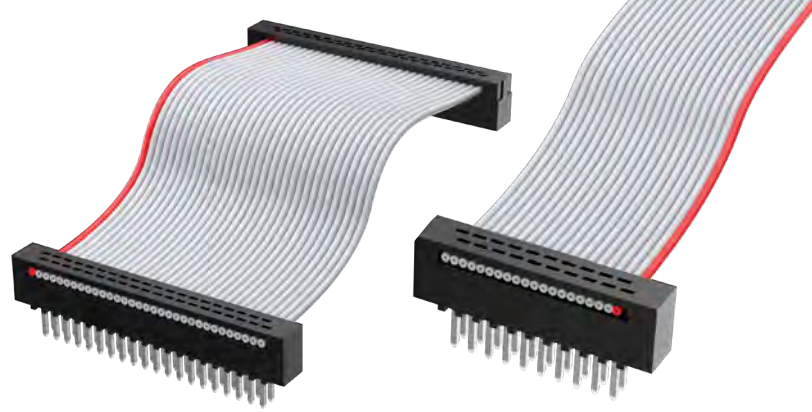

FFMD

Mates:
FLE*, SFMC*

TRANSFER END

Mates:
FTS, FTSH, EHF,
SHF, ESHF

SPECIFICATIONS

Insulator Material:

PBT
Terminal:
Phosphor Bronze

Contact:

BeCu (-T)
Plating:
Sn over 50 μ" (1.27 μm) Ni

Wire:

30 AWG
Operating Temp Range:
-40 °C to +105 °C

Current Rating (FFMD/SFMC):

2.5 A per pin
(2 pins powered)

Voltage Rating:

215 VAC/304 VDC

ALSO AVAILABLE
Contact Samtec

Other sizes

SERIES	NO. PINS PER ROW	END OPTION	OVERALL LENGTH	01	TRANSFER OPTION	OTHER OPTION
--------	------------------	------------	----------------	----	-----------------	--------------

FFMD
= Terminal Strip

-04, -05, -08, -10, -13, -17, -20, -25
(Standard sizes)

-S
= Single End
-D
= Double End
-T
= Transfer End

"XX.XX"
= Assembled Length

Leave blank for -S and -D End Options.

-N
= Notch Polarization on socket (-T end only) (Not available with -04 position)

-RW
= Reverse Wiring (Red wire opposite position #1)

-D "XX"
= Daisy Chain

-SR
= Strain Relief (Mates only with ESHF Series) (Not available with -O, -M, -R or -DXX)

-R
= Reversed

-M
= Middle Reversed (Requires -DXX)

-O
= Outside Reversed (Requires -DXX)

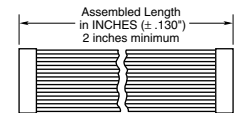
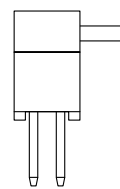
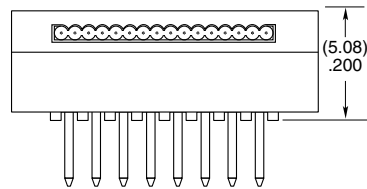
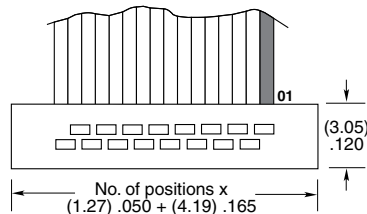

Assemble Length ("XX.XX")



Single End (-S)

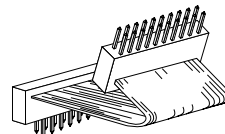

Double End (-D)

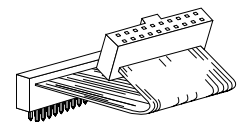

Transfer End (-T)

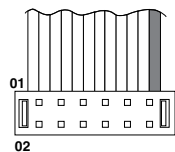

Reverse Wiring (-RW)

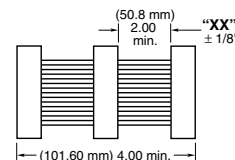

Daisy Chain (-D "XX")

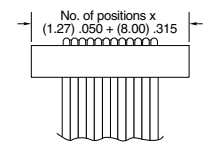

Strain Relief (-SR)

*Note:

Standard FFMD callout will not mate with FLE, SFMC. Must use gold plated callouts. (See drawing on web.) When mated with a socket, Wire 1 mates with Pin 2; Wire 2 mates with Pin 1, etc.

Note:

This Series is non-standard, non-returnable.

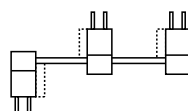

Reversed (-R)

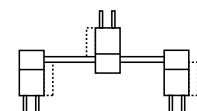

Middle Reversed (-M)

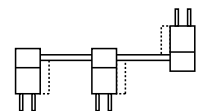

Outside Reversed (-O)

SHROUDED AND EJECTOR IDC HEADER

(1.27 mm) .050" PITCH • SHF/ESHF/EHF/ECF SERIES

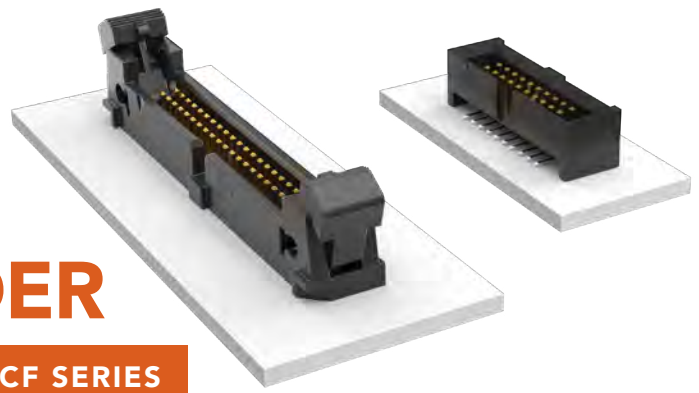

SHF/ESHF

Mates:
FFSD, FFTP (SHF)

EHF

Mates:
FFSD*, FFTP

***Important Note:**
EHF will not mate to FFSD with strain relief (-SR option), see ESHF series.

SPECIFICATIONS

Insulator Material:
Black Liquid Crystal Polymer
Terminal Material:
Phosphor Bronze
Plating:
Sn or Au over
50 μm (1.27 μm) Ni
Operating Temp Range:
-55 °C to +125 °C

PROCESSING

Lead-Free Solderable:
Yes
SMT Lead Coplanarity:
(0.10 mm) .004" max

SERIES	1	NO. PINS PER ROW	01	PLATING OPTION	D	TAIL OPTION		OTHER OPTION	
--------	---	------------------	----	----------------	---	-------------	--	--------------	--

SHF = Mates with FFSD without Strain Relief	04, 05, 06, 08, 10, 11, 12, 13, 15, 17, 20, 25 (Standard sizes)	-F = Gold flash on post, Matte Tin on tail	-TH = Through-hole	-LC = Locking Clip (Not available with -RA) (Manual placement required)
ESHF = Mates with FFSD with Strain Relief		-L = 10 μm (0.25 μm) Gold on post, Matte Tin on tail	-RA = Right-angle	-K = (6.50 mm) .256" DIA Polyimide Film Pick & Place Pad (-SM only)
			-SM = Surface Mount	-TR = Tape & Reel
				-FR = Full Reel Tape & Reel (must order max. quantity per reel; contact Samtec for quantity breaks)

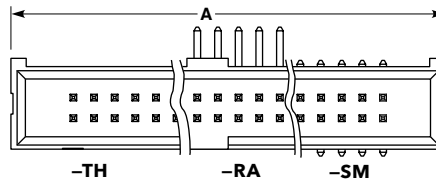

TYPE STRIP	A
SHF	No. of pins x (1.27) .050 + (6.35) .250
ESHF	No. of pins x (1.27) .050 + (10.16) .400

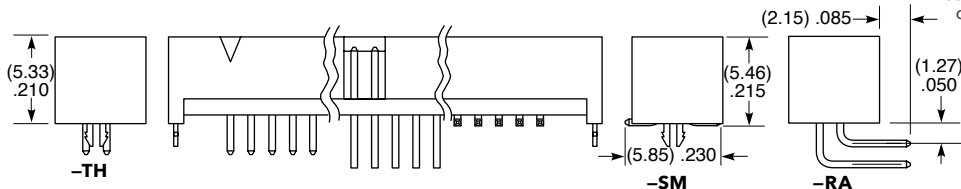

EHF	1	NO. PINS PER ROW	01	PLATING OPTION	D	TAIL OPTION		OTHER OPTION	
-----	---	------------------	----	----------------	---	-------------	--	--------------	--

04, 05, 08, 10, 13, 17, 20, 25
(Standard sizes)

-F
= Gold flash on post, Matte Tin on tail

-L
= 10 μm (0.25 μm) Gold on post, Matte Tin on tail

Leave blank for Through-hole version

-SM
= Surface Mount

-RA
= Right-angle

-"XX"
= Polarized Position (-RA not available)

-LC
= Locking Clip (-SM only) (Manual placement required)

-K
= (7.50 mm) .295" DIA Polyimide Film Pick & Place Pad

-P
= Pick & Place Pad (-SM only)

-TR
= Tape & Reel (-LC not available)

-FR
= Full Reel Tape & Reel (must order max. quantity per reel; contact Samtec for quantity breaks) (-LC not available)

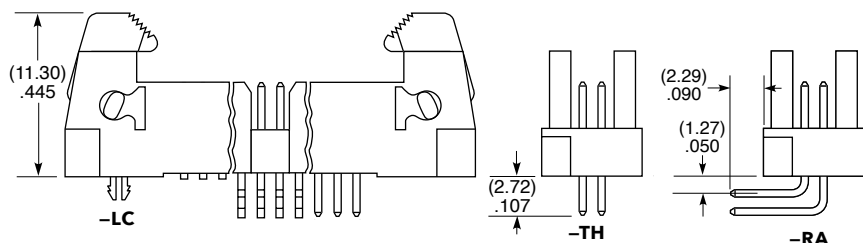
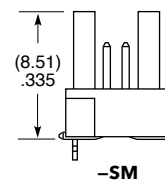
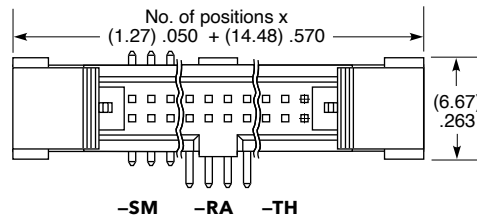

EJECTOR HEADER CAP (Locks FFSD cable to EHF header)

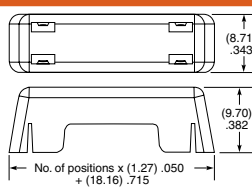

ECF - NO. PINS PER ROW

05, 08, 10, 13, 17, 20, 25

Note:
Some lengths, styles and options are non-standard, non-returnable.

TWISTED PAIR IDC CABLES

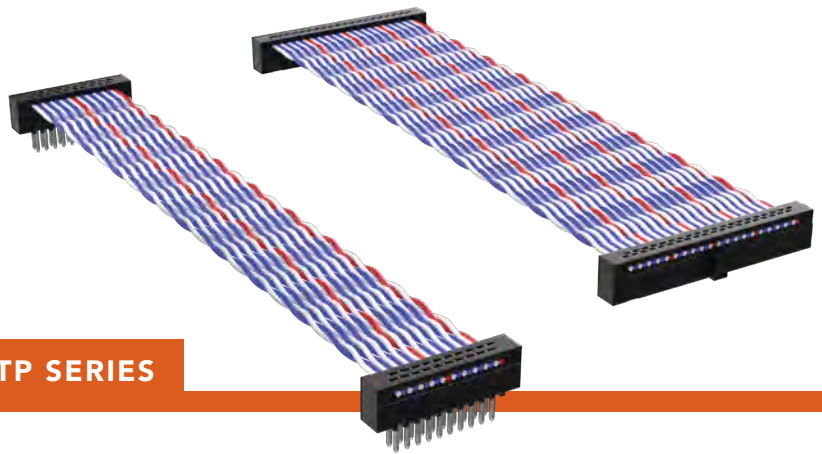

(1.27 mm) .050" PITCH • FFTP/FMTP SERIES

FFTP

Mates:
FTS, FTSH, EHF, SHF

FMTP

Mates:
FLE*, SFMC*

SPECIFICATIONS

Insulator Material:
PBT
Contact:
FFTP=BeCu
Terminal:
FMTP=Phosphor Bronze
Plating (FFTP):
FFTP=10 μ" (0.25 μm)
Au over 50 μ" (1.27 μm)
Ni on contact area; Sn over 50 μ" (1.27 μm) Ni
FMTP=Sn over 50 μ" (1.27 μm) Ni on balance
Wire:
30 AWG 7/38, Tinned,
Twisted Pair with PVC insulator
Operating Temp Range:
-40 °C to +105 °C
Lead Size Accepted:
(0.41 mm) .016" SQ
Insertion Depth (FFTP):
FFTP=(2.64 mm) .104" to
(3.17 mm) .125"

FFTP	NO. PINS PER ROW	END ASSEMBLY	ASSEMBLY LENGTH	01	N	OPTION
	-05, -08, -10, -13, -17, -20, -25 (Standard sizes)	-D = Double End	-03.85 = (97.79 mm) 3.85" -08.77 = (222.76 mm) 8.77" -18.00 = (457.20 mm) 18.00" (Standard lengths)		-N = Notch Polarization (Standard)	-R = Reverse Connector

ALSO AVAILABLE

Contact Samtec

Other sizes

FMTP	NO. PINS PER ROW	END ASSEMBLY	ASSEMBLY LENGTH	01	TRANSFER OPTION	OPTION
	-05, -08, -10, -13, -17, -20, -25 (Standard sizes)	-D = Double End -T = Transfer End	-03.85 = (97.79 mm) 3.85" -08.77 = (222.76 mm) 8.77" -18.00 = (457.20 mm) 18.00" (Standard lengths)		Leave blank for -D End Assembly. For -T End Assembly Specify "-N" (Socket has notch polarization)	-R = Reverse Connector

***Note:** Standard FMTP callout will not mate with FLE, SFMC. Must use gold plated callouts. (See drawing on web.)
When mated with a socket, Wire 1 mates with Pin 2; Wire 2 mates with Pin 1, etc.

Note:
This Series is non-standard, non-returnable.

FLAT FLEXIBLE CABLE (FFC) JUMPER & SOCKET

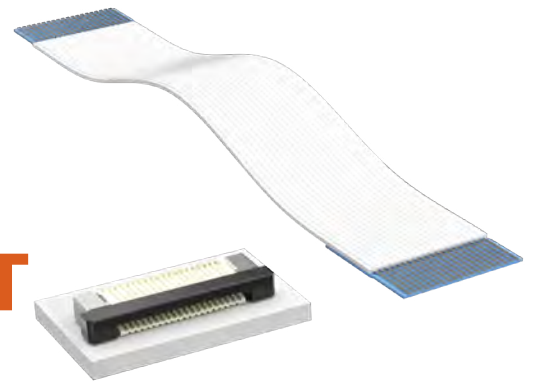

(0.50 mm) .0197" PITCH • FJH/ZF5S SERIES

FJH

Mates:
ZF5S

SPECIFICATIONS

Conductor:
Tin Plated Copper
Operating Temp Range:
-55 °C to +80 °C
Current Rating:
1.8 A per pin
(1 pin powered)
Voltage Rating:
195 VAC/276 VDC

OTHER SOLUTIONS

For 1.00 mm pitch flat flexible cable series, visit:
www.samtec.com?FJ
www.samtec.com?ZF1
www.samtec.com?FC1

Notes:

Stiffener color will be blue or black at Samtec's discretion.

Some sizes, styles and options are non-standard, non-returnable.

FJH	NO. OF POSITIONS	STYLE	LENGTH	STRIP LENGTH
	-10, -15, -20, -25, -30, -40, -43, -50 (Standard sizes)	-D = Double End -R = Reversed End	Length in inches -03.00 = (76.2 mm) 3.00" -06.00 = (152.4 mm) 6.00" -12.00 = (304.8 mm) 12.00" -24.00 = (609.6 mm) 24.00" (Standard Lengths)	-4 = (4.00 mm) .157"

NO. OF POSITIONS	A
-10	(5.50) .217
-15	(8.00) .315
-20	(10.50) .413
-25	(13.00) .512
-30	(15.50) .610
-40	(20.50) .807
-43	(22.00) .866
-50	(25.50) 1.00

ZF5S

Mates:
FJH

SPECIFICATIONS

Insulator Material:
Natural LCP
Contact Material:
Phosphor Bronze
Plating:
Sn over 50 μ" (1.27 μm) Ni
Operating Temp Range:
-55 °C to +105 °C
Current Rating:
1.8 A per pin
(1 pin powered)
Voltage Rating:
195 VAC/276 VDC
Weld Tab:
Phosphor Bronze

PROCESSING

Lead-Free Solderable:
Yes
SMT Lead Coplanarity:
(0.10 mm) .004" max (10-30)
(0.15 mm) .006" max (40-50)*
*(.004" stencil solution may be available; contact ipg@samtec.com)

Note:

Some sizes, styles and options are non-standard, non-returnable.

ZF5S	NO. OF POSITIONS	LEAD STYLE	PLATING OPTION	WT	OPTION
	-10, -15, -20, -25, -30, -40, -43, -50 (Standard sizes)	-01 = Contact Bottom	-T = Matte Tin	-WT = Weld Tab	-K = (3.00 mm) .118" DIA Polyimide Film Pick & Place Pad -TR = Tape & Reel -FR = Full Reel Tape & Reel (must order max. quantity per reel; contact Samtec for quantity breaks)

ALSO AVAILABLE
Contact Samtec

Vertical
Contact top
Other positions

RUGGED FEATURES

OPTIONS FOR HIGH-RELIABILITY, HIGH-RETENTION AND HIGH-CYCLE LIFE

RUGGEDIZING OPTIONS



JACK SCREWS

Ideal for high normal force, zippering and other rugged applications

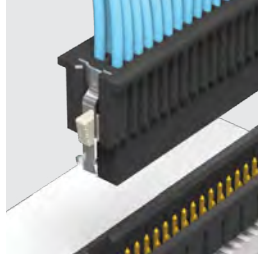

POSITIVE LATCHING

Manually activated latches increase unmating force by up to 200%

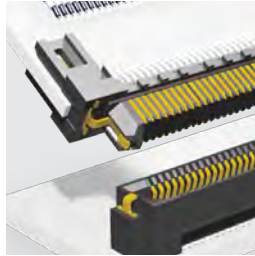

FRICTION LOCKS

Metal or plastic friction locks increase retention/withdrawal force



RETENTION PINS

Increase unmating force by up to 50%



BOARD LOCKS

Boards are mechanically locked together



WELD TABS

Significantly increase shear resistance of connector to PCB

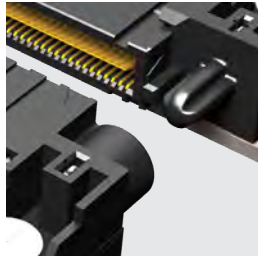

GUIDE POSTS

Easy and secure mating



SHIELDING

360° shielding reduces EMI

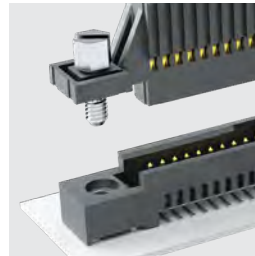

SCREW DOWNS

Secure mechanical attachment to the board

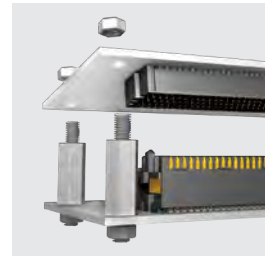

BOARD STANDOFFS

Precision machined standoffs for 5 mm to 30 mm board spacing

CONTACT SYSTEMS

TIGER EYE
CONTACT



High-reliability
High Mating Cycles
Multi-finger Contact

TIGER CLAW
CONTACT



Dual Wipe Contact
Pass-through Applications
Ultra-low Profile

BLADE & BEAM
CONTACT



Mating/Alignment "Friendly"
Cost-effective
Micro Pitch

TIGER BEAM
CONTACT



Best Cost
Reliable Performance
Post & Beam Contact

EDGE RATE
CONTACT



Designed for Signal Integrity
Superior Impedance Control
Reduced Broadside Coupling

HYPER CLAW
CONTACT



High-reliability
Four Points of Contact
Extreme Mating Cycles

INDUSTRY STANDARDS

PRODUCT SUPPORT & EXPERTISE

Samtec actively collaborates with leading Industry Standard groups to develop interconnect solutions that meet rigorous durability and performance requirements across a wide range of applications. The majority of Industry Standards we engage with address the following:

- Interconnection (cables & connectors)
- Sub-systems (typically daughter or carrier cards, which include functional compliance specifications defining electro-mechanicals and mechanicals)
- Transmission protocols (primarily software and firmware defining machine language to allow communication)
- Hardware (physical electro-mechanical devices)

Visit samtec.com/standards to learn more or contact standards@samtec.com to discuss your application.

STANDARD	PRODUCT	SERIES	PAGE
VITA™ 42 XMC™	SamArray®	YFS/YFT, JSOM	Contact Samtec.
VITA™ 88 XMC+™	SEARRAY™	SEAM/SEAF, JSOM	25
VITA™ 57.1 FMC™	SEARRAY™	SEAM/SEAF, JSOM	25
VITA™ 57.4 FMC+™	SEARRAY™	SEAM/SEAF, JSOM	25
VITA™ 74 VNX™	SEARRAY™	SEAM/SEAF, JSOM	25
VITA™ 90 VNX+™	SEARRAY™	SEAM/SEAF-RA, VBM/GPCC	25-26, 178-179
VITA™ 93 QMC™	AcceleRate® HD	ADM6/ADF6	21
PICMG® COM-HPC®	AcceleRate® HP	APM6/APF6	19
SGET OHFM™	AcceleRate® HD/AcceleRate® HP	ADM6/ADF6, APM6/APF6, JSOM	19, 21
PCI/104-EXPRESS™ & PCI/104-EXPRESS™ ONEBANK	Q2™	QMS/QFS	42
COAXPRESS®	High-Density BNC/FireFly™	HDBNC-TH, HDBNC-BH, HDBNC-EM, ECUO-B04	137, 192
QSFP	QSFP	FQSFP/QSFPC	103
USB/USBR	USB/AccliMate™	USB/USBR/MUSB/MUSBS/SPM, BCU/BPCU/BRU/RCU/RPCU/RPBU/SCPU/SCRUS/SCRU	232-234, samtec.com/usb
COMPUTE EXPRESS LINK® (CXL®)	Generate®	HSEC6	63

For a quick reference to more industry standards and products that meet them, visit samtec.com/standards-reference.

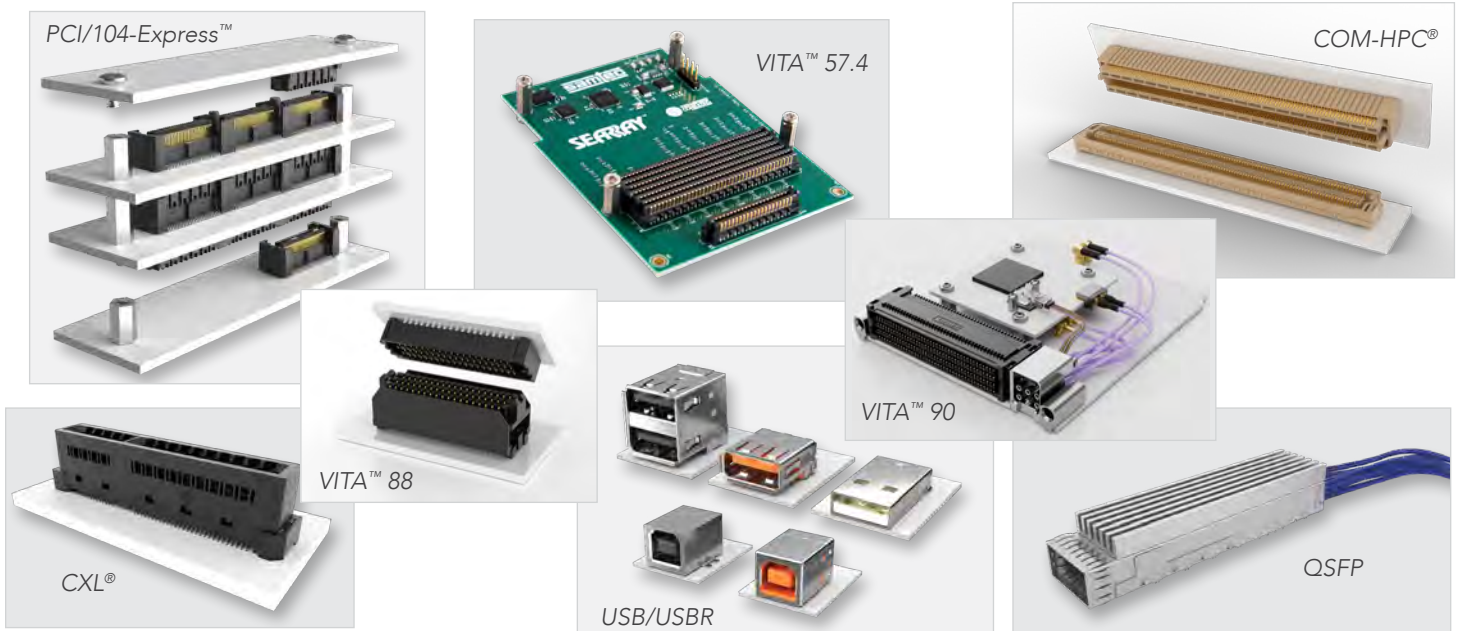

V42 XMC™

Rugged Mezzanine System for High-Performance VPX™ Card Cages

- 3.125 Gbps performance rating
- 10 mm & 12 mm stack heights; 96 total pins (6 x 16 configuration)
- Drop-in ready JSOM ejector jackscrews and mating high-density array cable assemblies available
- SOSA™ aligned connectors

V88 XMC+™

Improved Mezzanine Connectors for XMC+™ Applications

- Compatible with VITA™ 42 footprints
- Improved mating/unmating forces
- PCIe® 5.0+ speeds; SOSA™ aligned connectors

V57.1 FMC™

Leading FMC™ Mezzanine System for Advanced FPGA Integration

- HPC & LPC versions; 8.5 mm & 10 mm stack heights; 10 Gbps
- Many high-speed cable & loopback card options available
- Optional JSOM ejector jackscrews available
- SOSA™ aligned connectors

V57.4 FMC+™

Advanced State-of-the-Art FPGA Mezzanine Integration

- HSPC Main Connector has 560 pins (14 x 40 configuration), 24 multi-gigabit interfaces, up to 28 Gbps
- HSPCe Extension Connector has 80 pins (4 x 20 configuration) adding 8 multi-gigabit interfaces, 32 in total
- 8.5, 10 and 15.5 mm stack heights; SOSA™ aligned connectors

V90 VNX+™

VNX+™ Small Form Factor Modules

- Rugged, high-performance, scalable, low power consumption embedded controllers
- 200, 240, 320 & 400 pin connector choices (Right-angle SEARAY™)
- Optimized pinout for improved SI performance and density
- VITA™ 90.2: Expanded optical and coaxial connectivity provides routing flexibility (FireFly™ and GPCC 50/75 Ω contacts)
- VITA™ 90.3: Specialized pinout for PSU and filter modules
- 13 mm & 19 mm stack heights; mating cable assemblies available
- SOSA™ aligned connectors

V93 QMC™

Small Form Factor I/O Mezzanine Modules

- Enables modular, scalable design with rugged and reliable mechanical features
- Supports 32 Gbps NRZ/64 Gbps PAM4 performance
- 80 total pins (4 x 20 configuration); 9, 11, 14 & 16 mm stack heights
- Supports single, dual and triple width modules

PICMG® COM-HPC®

Next Gen Embedded System Design Scalability & Performance

- Supports edge server & robust embedded computing design applications
- System based on Samtec's AcceleRate® HP high-performance arrays
- 5 mm and 10 mm stack heights; 400 pin count connectors
- Supports interfaces such as PCIe® 6.0 (64 GT/s) & up to 200 Gb Ethernet

SGET oHFM™

Mezzanine System for Standardized FPGA SoMs

- Mid- to high-mid-range FPGA support
- Simplifying evaluation, prototyping and stock management
- Cost effective FPGA prototype to production solution
- Supports PCIe® 6.0 (64 GT/s)

PCI/104-Express™ & PCI/104-Express™ OneBank

Rugged, Stackable & Scalable Embedded Computer Applications

- Q2™ connectors with ground planes; 2.5 Gbps performance
- 3-banks have 156 signal pins, OneBank has 52 pins
- 15.24 mm & 22 mm stack heights; mating cable assemblies available

COAXPRESS®

Industrial/Professional Application High-Speed Imaging Standard

- Coaxial cable combined with high-speed serial data technology
- Up to 12.5 Gbps data rate per cable; supports 12G-SDI protocol
- High-Density BNC 75 Ω connectors and components

QSFP

Compact, Hot-Pluggable Transceiver I/O Connector

- Flyover® solution for optimized signal integrity; 112 Gbps PAM4
- Cage and 38-pin connector
- 30 AWG 100 Ω ultra low skew twinax cable
- 4 high-speed Tx pairs, 4 high-speed Rx pairs
- Meets high-speed protocols including 40/200/400 Gb Ethernet, PCIe®, OIF-CEI-28G, SAS and SATA

USB/USBR

Standardized Connection, Communication & Power Supply

- Type A, Type B, Mini, high retention and sealed versions
- IP67/IP68 sealed circular and rectangular cable systems

COMPUTE EXPRESS LINK® (CXL®)

Open Systems Interconnect Offering Memory-Semantic Access to Data and Devices Via Multiple Network Topologies

- High-speed, low-latency access to memory across the data center
- 0.60 mm pitch Generate® high-speed edge card connectors

PCI-SIG®, PCI Express®, and the PCIe® design marks are registered trademarks and/or service marks of PCI-SIG.

VITA/VNX/VNX+/FMC/FMC+/XMC/XMC+/QMC are all respective trademarks of VITA

EVALUATION & DEVELOPMENT KITS

From concept and prototype to development and production, Samtec-designed Evaluation and Development Kits simplify the design process and reduce time to market. Kits are available for many of our high-performance connector sets, standard high-speed cable assemblies, and optical configurations. Custom kits are also available via our "mix-and-match" design approach.

Visit samtec.com/kits or contact kitsandboards@samtec.com for a current list of kit availability.

SI EVALUATION KITS: BOARD-TO-BOARD



Generate® 0.60 mm Pitch High-Speed Edge Card (HSEC6-DV)



Generate® Differential Pair Edge Card (HSEC8-DP)



Edge Rate® 0.635 mm Pitch High-Speed Strips (ERM6/ERF6)



AcceleRate® mP Signal/Power Arrays (UDM6/UDF6)



AcceleRate® HP High-Performance Arrays (APM6/APF6)



AcceleRate® HD High-Density Arrays (ADM6/ADF6)



NovaRay® Extreme Density Arrays (NVAM/NVAF)



LP Array™ Low Profile Arrays (LPAM/LPAF)



FireFly™ 20+ Gbps Edge Card Socket (UEC5-2)



SEARAY™ High-Density Arrays (SEAM/SEAM-RA & SEAF/SEAF-RA)



ExaMAX® High-Speed Backplane Traditional Connectors (EBTF/EBTM)

PRECISION RF/ANALOG OVER ARRAY™ EVALUATION KITS



Bulls Eye® 50 GHz High-Performance Test System (BE40A)



Bulls Eye® 70 GHz High-Performance Test System (BE70A)

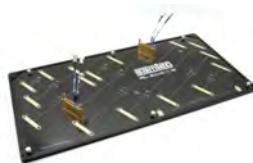

Bulls Eye® ISI 70 GHz & 90 GHz Test Systems (BE70A, BE90A)



SEARAY™ Analog Over Array™ Digital/Analog/Power Connectors (SEAM/SEAF)



Vertical Compression Mount Precision RF Connectors (1.35/1.85/2.40/2.92 mm)

SI EVALUATION KITS: CABLE



Flyover® QSFP Cable System
(FQSFP to ARC6 and other
End 2 options)



Flyover® QSFP
Double Density Cable System
(FQSFP-DD to NVAC/ARC6)



Flyover® QSFP 800G
Double Density Cable System
(FQSFP-DD to NVAC/CPC)



NovaRay® I/O Flyover® Panel
Mount Cable Systems (NVACE/
NVAC & NVA3P/NVA3E)



NovaRay® Flyover® Extreme
Performance Cable System
(NVAC/NVAM-CT)



Si-Fly® LP Low Profile
Cable System (CPC/CPI)



ExaMAX® Backplane Cable System
(EBCM/EBTF-RA)



AcceleRate® Flyover® Slim
Cable System (ARC6/ARF6)



AcceleRate® HP Flyover®
High-Performance Cable System
(ARP6/APF6-L)



AcceleRate® Mini Flyover®
Small Form Factor Cable
System (ARM6/AMF6)

OPTICS/FPGA DEVELOPMENT KITS

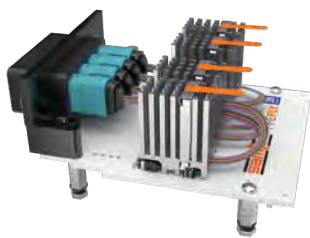

25/28 Gbps FireFly™ FMC+™ Kit



14 Gbps FireFly™ FMC™ Kit



28 Gbps FireFly™ Kit



FireHawk® Evaluation Kits



FireBlade™ FireFly™
OCP OAI EXP Module

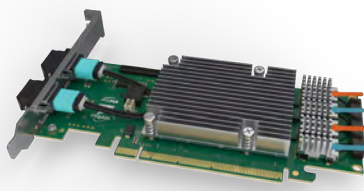

PCIe®-Over-Fiber
Adaptor Card (PCUO/PCOA)



VITA™ 57.4 FMC+™
HSPC & HSPC/HSPCe
Loopback Cards

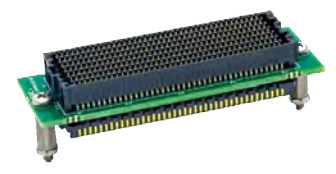

VITA™ 57.1 FMC™ &
VITA™ 57.4 FMC+™
Extender Cards

HIGH-SPEED CHANNEL PERFORMANCE

CHARACTERIZATION THAT ACCOUNTS FOR THE ENTIRE SIGNAL PATH

Samtec uses a channel-based approach to estimate connector performance in a system. The result is a realistic one number designation for all of Samtec's high-speed interconnects, called **Channel Performance Metric (CPM)**.

This one number designation allows for a side-by-side comparison of Samtec components. Noise contributions from, and interactions with, other parts of a predefined channel are considered. An example of a predefined channel is shown below.

Samtec's CPM reports connector capability that is more representative of actual performance in a system, replacing the connector only data of the past.

This real-world approach factors in all impairments, such as the crosstalk and reflections, inherent in a complete channel. Through Samtec's use of a common set of channel assumptions, relative comparison can then be made across the entire Samtec offering which is practical and realizable. Because Samtec's CPM is a function of necessary channel assumptions made, it is important to note that Samtec's CPM can and will vary from a customer specific application.

Visit samtec.com or contact SIG@samtec.com for technical support prior to final connector selection in any specific application.

Throughout the high-speed sections of this catalog, look for badges indicating Samtec's CPM one number rating for specific product series, for example:

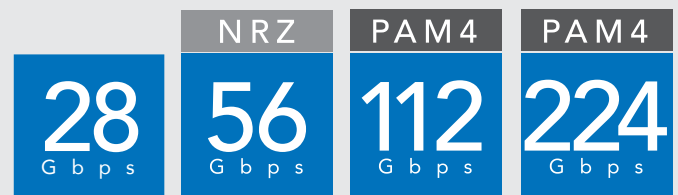

*Note: For speeds of 28 Gbps or less, NRZ encoding scheme is assumed.

Predefined Channel

Board-to-Board

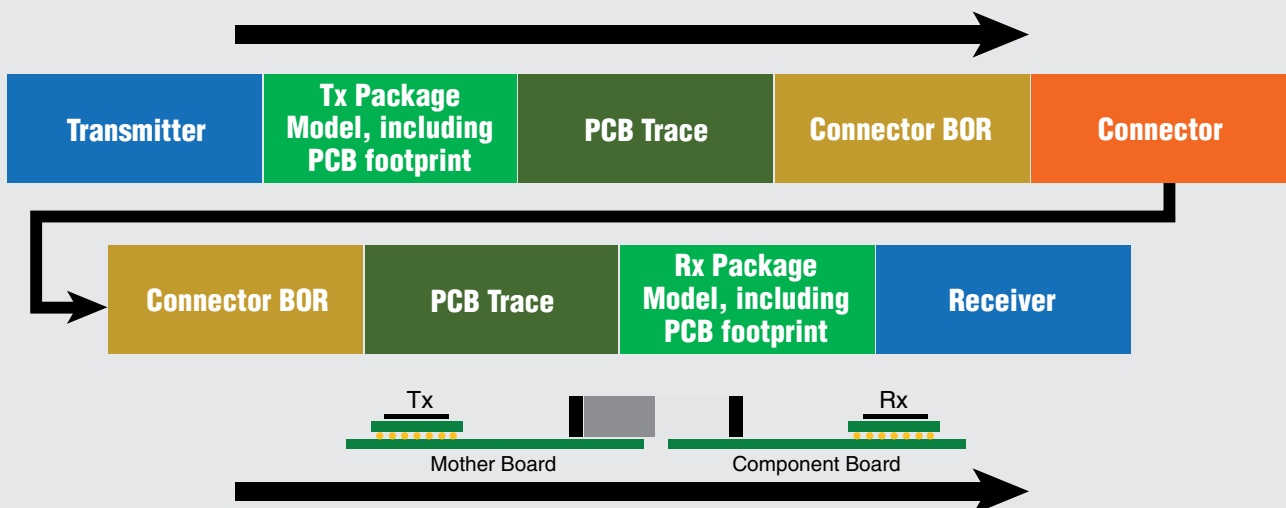

*Moderate levels of equalization are applied.

SPECIFICATIONS & TESTING



SPECIFICATIONS & STANDARD TEST PROCEDURES

Samtec products are subject to the following general specifications and standard test procedures.*

QUALITY ASSURANCE

Quality Program Certifications	ISO-9001 and/or IATF 16949
UL File Number	Visit samtec.com/quality
Sampling Procedures	ANSI/ASQ Z1.4
Calibration System Requirements	Per IATF 16949

INSULATOR

Specifications

Molding Plastics, Thermoplastic Polyesters	MIL-M-24519 Rev E
--	-------------------

Applied Tests***

Dielectric Breakdown Voltage	ASTM/ISO
AC Loss Characteristics	ASTM/ISO
Impact Resistance of Plastics	ASTM/ISO
DC Resistance	ASTM/ISO
High-Voltage, Low-Current Arc Resistance	ASTM/ISO
Water Absorption of Plastics	ASTM/ISO
Test for Tensile Properties of Plastics	ASTM/ISO
Deflection Temperature of Plastics	ASTM/ISO
Compressive Properties of Plastics	ASTM/ISO
Coefficient of Linear Thermal Expansion	ASTM/ISO
Shear Strength of Plastics	ASTM/ISO
Rockwell Hardness of Plastics	ASTM/ISO
Flexural Properties of Plastics	ASTM/ISO
Specific Gravity and Density of Plastics	ASTM/ISO

PLATING

Specifications

Gold	ASTM-B488
Tin	ASTM-B545**

Under Plating Specifications

Nickel	QQ-N-290**
Copper	AMS 2418

Applied Tests

Coating thickness (X-Ray Fluorescence)	ASTM-A-754-79
--	---------------

CONTACT & TERMINAL

Specifications***

Brass	ASTM/ISO
Phosphor Bronze	ASTM/ISO
Beryllium Copper	ASTM/ISO

ASSEMBLY

Testing Specifications

Test Methods for Electrical Connectors	EIA-364
Test Methods for Electronic/Electrical Components	EIA-364
Connections, Electrical, Solderless, Wrapped	EIA-364
Environmental Test Methods	EIA-364
Sockets (Lead, Electronic Components), General	EIA-364
Sockets, Plug-in Electronic Components, General	EIA-364

Packaging Specifications

Tape and Reel Packaging of Connectors	Visit samtec.com/packaging
Tray Packaging of Connectors	ANSI/EIA-960
Packaging Materials for ESD Sensitive Items	ANSI/ESD S541
Package Testing Procedures	ISTA-3A

OTHER SPECIFICATIONS

Insulation Resistance	5000 MΩ min
Flammability Rating	UL 94V-0 **** (Typically)

PRODUCT ENVIRONMENTAL COMPLIANCE

Product environmental compliance is a part specific issue for Samtec. To confirm the environmental compliance status of any Samtec product please contact the Product Environmental Compliance Group at PEC@samtec.com and/or visit samtec.com/quality.

Samtec has offered both lead-bearing and lead-free products for many years and will continue to support customers requiring products not compliant with the EU Directives, such as those specified for military, aerospace and specialty applications.

Proposition 65 statement: These products could expose you to chemicals which are known to the State of California to cause birth defects or other reproductive harm. For more information, visit P65Warnings.ca.gov.

LEAD FREE PROCESSING GUIDELINES

Lead-Free Wave Solderable	This product is compatible with wave solder pot temperatures between 260 °C and 270 °C with maximum exposure of the termination pins to the solder wave for 4 seconds.
Lead-Free Reflow Solderable	This product can withstand a maximum peak temperature of 260 °C; 255 °C for up to 30 seconds, and the longer dwell times required for lead-free reflow processing.

AUTOMOTIVE CERTIFICATION (ACD SERIES)

Samtec offers design and manufacture of electronic connectors, marketed as "ACD Series" (Automotive Certified Designs) for printed circuit boards. Samtec shall only comport with ISO/IATF 16949 on products it certifies as Automotive Custom Design ("ACD") or those designated with "A." in the Samtec part number preface of the Automotive Solutions Catalog.

Download the Automotive Solutions catalog at samtec.com/catalog, or contact AutoSalesGroup@samtec.com for qualifying products and alternative automotive application solutions.

Notes:

*Products with specifications other than those listed above are noted on the product's website page.

**With the exception of thickness.

***As dictated by material grade.

****Contact UL@samtec.com for additional flammability ratings.

INDEX BY BRAND NAME

AcceleRate[®], AcceleRate[®] HD, AcceleRate[®] HP, AcceleRate[®] Mini & AcceleRate[®] mP

APP6	0.635 mm AcceleRate [®] HP High-Performance Socket	19
APM6	0.635 mm AcceleRate [®] HP High-Performance Header	19
ADF6	0.635 mm AcceleRate [®] HD High-Density Socket	21
ADM6	0.635 mm AcceleRate [®] HD High-Density Header	21
UDF6	0.635 mm AcceleRate [®] mP Power/Signal Socket	23
UDM6	0.635 mm AcceleRate [®] mP Power/Signal Terminal	23
APP6-L	0.635 mm AcceleRate [®] HP High-Performance Socket	115
ARP6	0.635 mm AcceleRate [®] HP High-Performance Cable	115
ARC6	0.635 mm AcceleRate [®] Slim Cable	117
ARF6	0.635 mm AcceleRate [®] Slim Socket	117
AMF6	0.635 mm AcceleRate [®] Mini Small Form Factor Cable Socket	119
ARM6	0.635 mm AcceleRate [®] Mini Small Form Factor Cable	119

AccliMate™

ACX	AccliMate™ IP68 Sealed 12, 16 & 22 mm Assemblies	233
MCX	AccliMate™ IP67 Mini Push-Pull Cable Assemblies	233
BCU/BPCU	AccliMate™ IP67 USB-C Cable Assemblies	234
BRU	AccliMate™ IP67 USB-C Board Mount Socket	234
RPX	AccliMate™ IP68 Ethernet/USB Panel Mount Socket & Cable	234
SCRXS	AccliMate™ IP68 Sealed Circular USB/Ethernet Socket Cables	234

Edge Rate[®]

ERF5	0.50 mm Edge Rate [®] Rugged High-Speed Socket	49
ERM5	0.50 mm Edge Rate [®] Rugged High-Speed Header	49
ERF6	0.635 mm Edge Rate [®] Rugged High-Speed Socket	50
ERM6	0.635 mm Edge Rate [®] Rugged High-Speed Header	50
ERF8	0.80 mm Edge Rate [®] Rugged High-Speed Socket	51, 53, 54
ERM8	0.80 mm Edge Rate [®] Rugged High-Speed Header	51, 52, 54
ECDP	0.80 mm Edge Card Twinax Cable Assembly	134
ERCD	0.80 mm Edge Rate [®] Coax Cable Assembly	134

ExaMAX[®], ExaMAX[®] I/O

EBTM	2 mm ExaMAX [®] Backplane Header	87
EBDM-RA	2 mm ExaMAX [®] Direct Mate Orthogonal Header	88
EBTF-RA	2 mm ExaMAX [®] Backplane Socket, Right-Angle	88
EBCM	2 mm ExaMAX [®] Backplane Cable Header	89
EBCF	2 mm ExaMAX [®] Backplane Cable Socket	90
EBC/EBTC	2 mm ExaMAX [®] I/O Shielded Panel Mount Cable & Cage	109

FireFly™ & Flyover[®]

FSFP	Flyover™ SFP Cable System	99
FOSFP-X	Flyover™ OSFP Cable System	100
FQSF-DB	Flyover™ QSFP 800G Double Density Cable System	102
FQSF-DD	Flyover™ QSFP Double Density Cable System	102
FQSF	Flyover™ QSFP Cable System	103
ECUO	FireFly™ Optical Micro Flyover System™	137
ETUO	FireFly™ Extended Temp Optical Micro Flyover System™	138
ETMO	FireFly™ Extreme Environment Optical Micro Flyover System™	139
PCUO	PCIe [®] -Over-Fiber FireFly™ Cable	140
PTUO	PCIe [®] -Over-Fiber FireFly™ Extended Temp Cable	140
UCCB/UECS	FireFly™ Positive Latching Receptacle & Edge Card Socket	141
PCOA	PCIe [®] -Over-Fiber FireFly™ Adaptor Card	142

Flex Stack

AW	0.80 mm Flex Stack, Surface Mount Micro Board Stacker	279
MW	1 mm Flex Stack, Surface Mount Micro Board Header	281
FW	1.27 mm Flex Stack, Micro Board Stacker	287
ZML	1.27 mm Flex Stack, Shrouded Elevated Stacker	291
DWM	1.27 mm Flex Stack, Flexible Micro Board Stacker	292
HDWM	1.27 mm Flex Stack, High Temp Micro Board Stacker	292
LTM	2 mm Flex Stack, Shrouded Terminal Strip	300
ZLTM	2 mm Flex Stack, Shrouded Elevated Terminal Strip	300
TW-SM	2 mm Flex Stack, Flexible Board Stacker, SMT	302
MTSW	2.54 mm Flex Stack, High Temp Modified SQ Post Header	314, 315
HTSW	2.54 mm Flex Stack, Modified SQ Post Header	314, 315
MTLW	2.54 mm Flex Stack, Low Profile .025" SQ Post Header	316
TLW	2.54 mm Flex Stack, Low Profile .025" SQ Post Header	316
HW	2.54 mm Flex Stack, Flexible Board Stacker	317
DW	2.54 mm Flex Stack, Flexible Board Stacker, .110" Tail	318
EW	2.54 mm Flex Stack, Flexible .025" SQ Board Stacker	318
ZW	2.54 mm Flex Stack, Flexible .025" SQ Board Stacker	318
HTSS	2.54 mm High Temp Shrouded Terminal	319
TSS	2.54 mm Flex Stack, Shrouded Header	319
ZSS	2.54 mm Flex Stack, Elevated Shrouded Header	319
HTST	2.54 mm High Temp Shrouded Cable Terminal	333
TST	2.54 mm Flex Stack, Shrouded Cable Header	333
ZST	2.54 mm Flex Stack, Elevated Shrouded Cable Header	333
STMM	2 mm Flex Stack, Shrouded Terminal Cable Strip	337
ZSTMM	2 mm Flex Stack, Shrouded Elevated Cable Header	337

FleXYZ™

TMM-TH	2 mm FleXYZ™ Low Profile Through-Hole Header	296
MTMM	2 mm FleXYZ™ Modified Through-Hole Header	297
TMMH-TH	2 mm FleXYZ™ Flexible Through-Hole Header	299
TW-TH	2 mm FleXYZ™ Flexible Board Stacker, Through-Hole	302

ESQT	2 mm FleXYZ™ Flexible Elevated Socket Strip	304
SQT	2 mm FleXYZ™ Cost-Effective Rugged Socket, Square Tail	305
SQW	2 mm FleXYZ™ Cost-Effective Rugged Socket, Solder Tail	305

FOURRAY™

FOLC	1.27 mm FOURRAY™ High-Density Tiger Eye™ Socket	240
MOLC	1.27 mm FOURRAY™ High-Density High-Reliability Header	240
SOLC	0.635 mm FOURRAY™ Quad Row SMT Socket	283
TOLC	0.635 mm FOURRAY™ Quad Row SMT Terminal	283

Generate[®]

HSEC6	0.60 mm Generate [®] Vertical Card Socket	63
HTEC8	0.80 mm Generate [®] Rugged Card Socket	64
HSEC8	0.80 mm Generate [®] Card Socket	65, 66, 67, 68
HSEC1	1.00 mm Generate [®] Vertical Card Socket	69
GC6	0.60 mm Generate [®] Edge Card Cable Assembly	125
GC6RF	Generate [®] High-Speed Test Cable Assembly	126

Halo[®]

HLF6	Halo [®] Rugged High-Density Socket	144
HALO-C	Halo [®] Next Gen Mid-Board Optical Transceiver	145

LP Array™

LPAF	1.27 mm LP Array™ High-Speed Open-Pin-Field Socket	31
LPAM	1.27 mm LP Array™ High-Speed Open-Pin-Field Terminal	31

Micro Mate™

S1SS(T)	1 mm Micro Mate™ Socket Assembly, Single Row	250
S1SD(T)	1 mm Micro Mate™ Socket Assembly, Double Row	251
T1PS(T)	1 mm Micro Mate™ Panel Mount Terminal, Single Row	252
T1SS(T)	1 mm Micro Mate™ Terminal Assembly, Single Row	252
T1PD(T)	1 mm Micro Mate™ Panel Mount Terminal, Double Row	253
T1SD(T)	1 mm Micro Mate™ Terminal Assembly, Double Row	253

Mini Mate[®]

IPS1	2.54 mm Mini Mate [®] Isolated Power Connector Socket	223
IPT1	2.54 mm Mini Mate [®] Isolated Power Connector Terminal	223
MMSX(T)	2.54 mm Mini Mate [®] Wire to Board Cable	260
IPL1	2.54 mm Mini Mate [®] Shrouded Power Cable Terminal	261

mPOWER[®]

UMPS	mPOWER [®] Ultra Micro Power Socket	207
UMPT	mPOWER [®] Ultra Micro Power Terminal	208
UMPC(T)	mPOWER [®] Ultra Micro Power Cable-to-Board Assembly, Socket	209
UMPE(T)	mPOWER [®] Ultra Micro Power Cable-to-Board Assembly, Terminal	210
UMPI(T)	mPOWER [®] Ultra Micro Power Cable-to-Cable Assembly, Socket	211

NovaRay[®], NovaRay[®] I/O

NVAF	NovaRay [®] Extreme Density & Performance Socket	17
NVAM	NovaRay [®] Extreme Density & Performance Terminal	17
NVBF	NovaRay [®] Micro Rugged Backplane Socket	83
NVBM-RA	NovaRay [®] Micro Rugged Backplane Right-Angle Terminal	83
NVCF	NovaRay [®] Micro Rugged Backplane Cable, Socket	84
NVCM-RA	NovaRay [®] Micro Rugged Backplane Cable, Terminal	85
NVACP	NovaRay [®] I/O Extreme Performance Panel Mount Cable	105
NVACE	NovaRay [®] I/O Extreme Performance Cable Assembly	106
NVA3E	NovaRay [®] I/O Rugged 38999 Cable Assembly	107
NVA3P	NovaRay [®] I/O Rugged 38999 Panel Mount Cable Assembly	107
NVAC	NovaRay [®] Extreme Density & Performance Cable Assembly	113
NVAM-CT	NovaRay [®] Terminal for NVAC Series	113

PowerStrip™

LPHS	PowerStrip™ EXtreme LPHPower™ Socket	213
LPHT	PowerStrip™ EXtreme LPHPower™ Terminal	213
ET6OS	PowerStrip™ EXtreme Ten60Power™ Socket	215
ET6OT	PowerStrip™ EXtreme Ten60Power™ Terminal	215
UPPT	3.81 mm PowerStrip™/20 Amp Hermaphroditic Power System	217
UPS/UPT	3.81 mm PowerStrip™/20 Amp Power Socket & Terminal	217
MPS/MPT	5 mm PowerStrip™/30 Amp Power Socket & Terminal	218
MPS/MPTC	PowerStrip™/30 Amp Signal/Power Combo Socket & Terminal	219
PESC/PET	6.35 mm PowerStrip™/40 Amp High Power Socket & Terminal	220
PESC/PETC	PowerStrip™/40 Amp Signal/Power Socket & Terminal	221
MPSS	5 mm PowerStrip™/30 Amp Power Cable Assembly	262
MPPC	PowerStrip™/30 Amp Combo Cable Assembly	263
PESS	6.35 mm PowerStrip™/40 Amp Cable Assembly	264

Power Mate[®]

IPBS	4.19 mm Power Mate [®] Isolated Power Socket	224
IPBT	4.19 mm Power Mate [®] Isolated Power Terminal	224
PMSX(T)	4.19 mm Power Mate [®] Wire to Board Power Cable	259

Q Strip[®], Q Pairs[®], Q2™, Q Rate[®]

QSH	0.50 mm Q Strip [®] High-Speed Ground Plane Socket	39, 46
QTH	0.50 mm Q Strip [®] High-Speed Ground Plane Header	39, 46
QSE	0.80 mm Q Strip [®] High-Speed Ground Plane Socket	40
QTE	0.80 mm Q Strip [®] High-Speed Ground Plane Header	40
QSS	0.635 mm Q Strip [®] High-Speed Ground Plane Socket	41, 46
QTS	0.635 mm Q Strip [®] High-Speed Ground Plane Header	41, 46

QFS	0.635 mm Q2™ Rugged Ground Plane Socket	42, 47
QMS	0.635 mm Q2™ Rugged Ground Plane Header	42, 47
QFSS	0.635 mm Q2™ Shielded Ground Plane Socket	43
QMSS	0.635 mm Q2™ Shielded Ground Plane Header	43
ORF8	0.80 mm Q Rate [®] Slim Body Ground Plane Socket	44, 47
ORM8	0.80 mm Q Rate [®] Slim Body Ground Plane Header	44, 47
EQCD	0.80 mm Q Strip [®] Coax Cable Assembly	134
EQRD	0.80 mm Q Rate [®] Coax Cable Assembly	134
HQCD	0.50 mm Q Strip [®] Coax Cable Assembly	134

Razor Beam™

LSHM	0.50 mm Razor Beam™ High-Speed Hermaphroditic Strip	57
LSEM	0.80 mm Razor Beam™ High-Speed Hermaphroditic Strip	58
LSS	0.635 mm Razor Beam™ High-Speed Hermaphroditic Strip	58
HLCD	0.50 mm Razor Beam™ High-Speed Cable Assembly	134

SEARAY™, SEARAY™ 0.80 mm

SEAF	1.27 mm SEARAY™ High-Density Open-Pin-Field, Socket	25, 26
SEAM	1.27 mm SEARAY™ High-Density Open-Pin-Field, Terminal	25, 26
SEAFP	1.27 mm SEARAY™ Press-Fit High-Density Array, Socket	27
SEAMI	1.27 mm SEARAY™ 85 SQ Tuned High-Density Array, Terminal	27
SEAMP	1.27 mm SEARAY™ Press-Fit High-Density Array, Terminal	27
SEAR	1.27 mm SEARAY™ High-Density Riser, 85 SQ	27
SEAF8	0.80 mm SEARAY™ Ultra-High Density Open-Pin-Field Socket	29
SEAM8	0.80 mm SEARAY™ Ultra-High Density Open-Pin-Field Terminal	29
SEAC	1.27 mm SEARAY™ High-Speed/High-Density Jumper	131

Si-Fly[®] LP, Si-Fly[®] HD

CPC	Si-Fly [®] LP Low Profile High-Density Cable Assembly	121
CPI	Si-Fly [®] LP Low Profile High-Density Interconnect	121
SFC	Si-Fly [®] HD Co-Packaged Cable Assembly	123
SFCM	Si-Fly [®] HD Co-Packaged Substrate Connector	123
SFNC	Si-Fly [®] HD Near-Chip Cable Assembly	124
SFNM	Si-Fly [®] HD Near-Chip Board Connector	124

Tiger Beam™

CLE	0.80 mm Tiger Beam™ Cost-Effective Micro Socket	278
MLE	1 mm Tiger Beam™ Cost-Effective Micro Socket	282
FLE	1.27 mm Tiger Beam™ Cost-Effective Reliable Socket	289
TLE	2 mm Tiger Beam™ Cost-Effective Reliable Socket	307
HLE	2.54 mm Tiger Beam™ Cost-Effective Reliable Socket	324

Tiger Buy™

SLM	1.27 mm Tiger Buy™ Low Profile Through-Hole Micro Socket	294
SMS	1.27 mm Tiger Buy™ Through-Hole Micro Socket	294
LS2	2 mm Self-Mating Hermaphroditic Strip	308
SSQ	2.54 mm Tiger Buy™ Socket .025" SQ Post	320
SSW	2.54 mm Tiger Buy™ Socket	320, 321
ESQ	2.54 mm PC/104™ Elevated Socket	323
ESW	2.54 mm PC/104™ Elevated Socket	323
BSW	2.54 mm Bottom Mount Socket Strip	326
SLW	2.54 mm Tiger Buy™ Low Profile Socket Strip	327

Tiger Claw™

CLM	1 mm Tiger Claw™ Rugged Reliable Micro Socket	282
CLP	1.27 mm Tiger Claw™ Low Profile Dual Wipe Socket	288
MMS	2 mm Tiger Claw™ Socket Strip	306
CLT	2 mm Tiger Claw™ Low Profile Dual Wipe Socket	307
SSM	2.54 mm Tiger Claw™ Pass-Through SMT Socket	322
BCS	2.54 mm Tiger Claw™ Pass-Through, Through-Hole Socket	325

Tiger Eye™

SFM	1.27 mm Tiger Eye™ High-Reliability Socket	237
SFML	1.27 mm Tiger Eye™ High-Reliability Locking Socket	237
SFC	1.27 mm Tiger Eye™ Cost-Effective Reliable Socket	239
SFMC	1.27 mm Tiger Eye™ Flexible Pin Count Socket	241
SEM	0.80 mm Tiger Eye™ Micro Socket	243
S2M	2 mm Tiger Eye™ Wire to Board Cable Socket	245
SMM	2 mm Tiger Eye™ High-Reliability Socket	246
SFSX(T)	1.27 mm Tiger Eye™ Wire to Board Cable	254, 255
S2SX(T)	2 mm Tiger Eye™ Wire to Board Socket Cable	256
SESDT	0.80 mm Tiger Eye™ Wire to Board Socket Cable	257
TCXD	2 mm Tiger Eye™ IDC High-Reliability Cables	334, 335
FFXD	1.27 mm Tiger Eye™ IDC Ribbon Cable Assemblies	338, 339
FXTP	1.27 mm Tiger Eye™ IDC Twisted Pair Cables	341

URSA[®] I/O

B1SD(T)	URSA [®] I/O Ultra Rugged Socket Cable Assembly	227
P1PD(T)	URSA [®] I/O Ultra Rugged Panel Mount Terminal Cable	228
P1M	URSA [®] I/O Ultra Rugged Board Mount I/O Connector	229
B1SM	URSA [®] I/O Panel Mount Jack Cable with SMPM Contacts	230
P1SM	URSA [®] I/O Panel Mount Plug Cable with SMPM Contacts	230

XCede[®] HD

HDTM	1.80 mm XCede [®] HD Vertical Backplane Header	93
HDTF	1.80 mm XCede [®] HD Right-Angle Backplane Receptacle	94

Series	Description	Page	Series	Description	Page
75T	V-Band Threaded Flexible Waveguide Board Connector	180	PRFM0	Precision SMPM Cable Connectors, 65 GHz	166
100	50 Ω Precision 1.00 mm Compression Jacks	157	PRFS1	Precision SSMA Cable Connectors, 34 GHz	162
135	50 Ω Precision 1.35 mm Compression Jacks	158	RF047-A	50 Ω .047" Overshield DIA 29 AWG mmWave Cable	157-161, 163, 166, 168, 179, 182, 195
185	50 Ω Precision 1.85 mm Compression Jacks	159	RF058	50 Ω RF Cable Assembly, RG 58 Cable	184-187
240	50 Ω Precision 2.40 mm Compression Jacks	160	RF085	50 Ω .085" Overshield DIA 24 AWG mmWave Cable	160-161
292	50 Ω Precision 2.92 mm Compression Jacks	161	RF086	50 Ω .086" Overshield DIA 23 AWG mmWave Cable	159-161, 163, 166, 168
BE40A	50 GHz & 40 GHz Bulls Eye® Assembly, Double Row	177	RF174	50 Ω RF Cable Assembly, RG 174 Cable	184-189
BE70A	70 GHz Bulls Eye® Assembly, Single or Double Row	177	RF178	50 Ω RF Cable Assembly, RG 178 Cable	184-189
BE71A	71 GHz Bulls Eye® Assembly, Single or Double Row, Nitrowave™ Cable	175	RF179	75 Ω RF Cable Assembly, RG 179 Cable	190, 193-194
BE90A	90 GHz Bulls Eye® Assembly, Single or Double Row	176	RF180	50 Ω .178" Overshield DIA, 16 AWG μWave Cable	163, 170-171
BNC5-CA	50 Ω BNC Cable Connectors	188	RF23C	50 Ω mmWave Cable, 23 AWG, Copper Shield	160-161, 163, 166, 168
BNC7T	75 Ω 12G-SDI BNC Jacks	191	RF23S	50 Ω μWave Cable, 23 AWG Solid FEP Dielectric	162
BNC7T-CA	75 Ω 12G-SDI BNC Cable Connectors	190	RF25S	50 Ω μWave Cable, 25 AWG Solid FEP Dielectric	163, 168
C28S	100 Ω Shielded Twisted Pair Twinax Cable Assembly	195	RF280	50 Ω .277" Overshield DIA, 11 AWG μWave Cable	163, 170-171
CJT	100 Ω Twinax Jacks	195	RF316	50 Ω RF Cable Assembly, RG 316 Cable	184-189
DIN7A	75 Ω, 12G-SDI DIN 1.0/2.3 Jacks	193	RF402	50 Ω RG 402 19 AWG Semi-Flexible μWave Cable	163
DIN7A-CA	75 Ω, 12G-SDI DIN 1.0/2.3 Cable Connectors	193	RF405	50 Ω RG 405 24 AWG Semi-Flexible μWave Cable	163, 168
GC47	50 Ω Precision Ganged SMPM Assembly, .047" Cable	164	RFA6T	75 Ω RF Cable Assembly, RG 6 Cable	190, 192-193
GC86	50 Ω Precision Ganged SMPM Assembly, .086" Cable	164	RFB6T	75 Ω RF Cable Assembly, 1694A Cable	190, 192-193
GPCC-16	75 Ω RF Size 16 Coaxial Contact	179	RFB8T	75 Ω RF Cable Assembly, 1855A Cable	192-193
GPCC-20	50 Ω RF Size 20 Coaxial Contact	179	RFC6T	75 Ω RF Cable Assembly, Belden 4694R Cable	190, 192-193
GPPB	50 Ω Precision Ganged SMPM Block, Board-to-Board	164	RFC8T	75 Ω RF Cable Assembly, Belden 4855R Cable	192-193
GPPC	50 Ω Ganged SMPM Cable Board Mates	165	RS316	50 Ω RF Cable Assembly, Double-Shielded RG 316 Cable	184-188
GRF1-C	5.00 mm 50 Ω Ganged Micro-Mini RF Plugs, Cable	195	SMA	50 Ω Precision SMA Jacks	163
GRF1H-C	5.00 mm 50 Ω Ganged Hybrid Micro-Mini RF Cable	195	SMA-CA	50 Ω SMA Low Frequency Cable Connectors	184
GRF1-J	5.00 mm 50 Ω Ganged Micro-Mini RF Jacks, PCB Mount	195	SMB5	50 Ω SMB Jacks	189
GRF1-P	5.00 mm 50 Ω Ganged Micro-Mini RF Plugs, PCB Mount	195	SMB5-CA	50 Ω SMB Cable Connectors	189
GRF7-C	5.00 mm 75 Ω Ganged Micro-Mini RF Plugs, Cable	195	SMB7H	75 Ω SMB Jacks	194
GRF7H-C	5.00 mm 75 Ω Ganged Hybrid Micro-Mini RF Cable	195	SMB7H-CA	75 Ω SMB Cable Connectors	194
GRF7-J	5.00 mm 75 Ω Ganged Micro-Mini RF Jacks, PCB Mount	195	SMP	50 Ω Precision SMP Plugs	169
GRF7-P	5.00 mm 75 Ω Ganged Micro-Mini RF Plugs, PCB Mount	195	SMP-B	50 Ω Precision SMP Bullet Adaptors	169
HDBNC	75 Ω, 12G-SDI High-Density BNC Jacks	192	SMPM	50 Ω Precision SMPM Plugs	167
HDBNC-CA	75 Ω, 12G-SDI High-Density BNC Cable Connectors	192	SMPMT	50 Ω Precision SMPM Threaded Plugs	167
IJ5	4.00 mm IsoRate® 50 Ω High Isolation RF Jack Strip	195	TNC	50 Ω TNC Jacks	187
IJ5C	4.00 mm IsoRate® 50 Ω High Isolation RF Cable	195	TNC-CA	50 Ω TNC Cable Connectors	187
IJ5H	4.00 mm IsoRate® 50 Ω High Isolation Hybrid RF Cable	195	VBM	Rugged, Blind Mate Block Module	178
IP5	4.00 mm IsoRate® 50 Ω High Isolation RF Plug Strip	195	WF15	V-Band Flexible Waveguide Assembly	180
LL018	18 GHz Nitrowave™ High-Performance μWave Cable	154	WGBA	Between-Series Waveguide Flange Adaptor	180
LL032	32 GHz Nitrowave™ High-Performance μWave Cable	154			
LL043	43.5 GHz Nitrowave™ High-Performance μWave Cable	153			
LL071	71 GHz Nitrowave™ High-Performance μWave Cable	153			
LL095	95 GHz Nitrowave™ High-Performance μWave Cable	152			
LL110	110 GHz Nitrowave™ High-Performance μWave Cable	152			
MCX	50 Ω MCX Jacks & Plugs	185			
MCX-CA	50 Ω MCX Cable Connectors	185			
MCX7	75 Ω MCX Jacks & Plugs	195			
MCX7-CA	75 Ω MCX Cable Connectors	195			
MH081	50 Ω Micro High Frequency RF Cable, 0.81 mm DIA	183			
MH113	50 Ω Micro High Frequency RF Cable, 1.13 mm DIA	183			
MMCX	50 Ω MMCX Jacks & Plugs	186			
MMCX-CA	50 Ω MMCX Cable Connectors	186			
MMCX7	75 Ω MMCX Jacks & Plugs	195			
MMCXV	50 Ω MMCX High-Vibration Jacks & Plugs	195			
MMCXV-CA	50 Ω MMCX High-Vibration Cable Connectors	195			
PRF00	Precision SMP Cable Connectors, 40 GHz	168			
PRF01	Precision SMA Cable Connectors, 18 GHz	163			
PRF04	Precision TNCA Cable Connectors, 18 GHz	171			
PRF06	Precision N Type Cable Connectors, 18 GHz	170			
PRF10	Precision 1.00 mm Cable Connectors, 110 GHz	157			
PRF13	Precision 1.35 mm Cable Connectors, 90 GHz	158			
PRF18	Precision 1.85 mm Cable Connectors, 65 GHz	159			
PRF24	Precision 2.40 mm Cable Connectors, 50 GHz	160			
PRF35	Precision 3.50 mm Cable Connectors, 34 GHz	162			
PRF92	Precision 2.92 mm Cable Connectors, 40 GHz	161			
PRFBA	Precision 50 Ω Between-Series Bullet Adaptors	173			
PRFIA	Precision 50 Ω In-Series Bullet Adaptors	172			



INDEX BY SERIES

Series	Description	Page	Series	Description	Page	Series	Description	Page
ACD	Automotive Certified Design	349	ERF5	0.50 mm Edge Rate [®] Rugged High-Speed Socket	49	HSEC8-DP	0.80 mm Generate [®] Differential Pair Card Socket	68
ACP-12	AcciiMate™ IP68 Sealed 12 mm Cable Assembly	233	ERF6	0.635 mm Edge Rate [®] Rugged High-Speed Socket	50	HSEC8-DV	0.80 mm Generate [®] Vertical Card Socket	65
ACP-16	AcciiMate™ IP68 Sealed 16 mm Cable Assembly	233	ERF8	0.80 mm Edge Rate [®] Rugged High-Speed Socket	51	HSEC8-EM	0.80 mm Generate [®] Edge Mount Card Socket	66
ACP-22	AcciiMate™ IP68 Sealed 22 mm Cable Assembly	233	ERF8-EM	0.80 mm Edge Rate [®] Rugged Edge Mount Socket	53	HSEC8-PE	0.80 mm Generate [®] Pass-Through Card Socket	67
ACR-12	AcciiMate™ IP68 Sealed 12 mm Panel Assembly	233	ERF8-RA	0.80 mm Edge Rate [®] Rugged Right-Angle Socket	53	HSEC8-PV	0.80 mm Generate [®] Power/Signal Combo Socket	67
ACR-16	AcciiMate™ IP68 Sealed 16 mm Panel Assembly	233	ERM5	0.50 mm Edge Rate [®] Rugged High-Speed Header	49	HSEC8-RA	0.80 mm Generate [®] Right-Angle Card Socket	66
ACR-22	AcciiMate™ IP68 Sealed 22 mm Panel Assembly	233	ERM6	0.635 mm Edge Rate [®] Rugged High-Speed Header	50	HS-OSFP	Heat Sink for OSFP	101
ADF6	0.635 mm AccelRate [®] HD High-Density Socket	21	ERM8	0.80 mm Edge Rate [®] Rugged High-Speed Header	51	HS-QSFP	Heat Sink for QSFP	103
ADM6	0.635 mm AccelRate [®] HD High-Density Header	21	ERM8-EM	0.80 mm Edge Rate [®] Rugged Edge Mount Header	52	HS-QSFP-D8	Heat Sink for QSFP-D8	102
AMF6	AccelRate[®] Mini Small Form Factor Cable Socket	119	ERM8-RA	0.80 mm Edge Rate [®] Rugged Right-Angle Header	52	HS-SFP	Heat Sink for SFP	99
APF6	0.635 mm AccelRate [®] HP High-Performance Socket	19	ESCA	0.80 mm SEARAY™ High-Speed Cable Assembly	131	HTEC8	0.80 mm Generate [®] Rugged Card Socket	64
APF6-L	0.635 mm AccelRate[®] HP Cable Assembly Socket	115	ESHF	1.27 mm Shrouded IDC Header	340	HTMS	1.27 mm High Temp Through-Hole Micro Terminal	290
APM6	0.635 mm AccelRate [®] HP High-Performance Header	19	ESQ	2.54 mm PC/104™ Elevated Socket	323	HTSS	2.54 mm High Temp Shrouded Terminal	319
ARC6	0.635 mm AccelRate [®] Slim Cable	117	ESQT	2 mm FlexYZ™ Flexible Elevated Socket Strip	304	HTST	2.54 mm High Temp Shrouded Cable Terminal	333
ARF6	0.635 mm AccelRate [®] Slim Socket	117	ESQT-368	2 mm PC/104-Plus™ Self-Nesting Socket	304	HTSW	2.54 mm High Temp Terminal	310
ARM6	AccelRate[®] Mini Small Form Factor Cable	119	ESW	2.54 mm PC/104™ Elevated Socket	323	HW-SM	2.54 mm Flex Stack, Board Stacker, Surface Mount	317
ARP6	0.635 mm AccelRate[®] HP High-Performance Cable	115	ET60S	2.54 mm PowerStrip™ EXTreme Ten60Power™ Socket	215	HW-TH	2.54 mm Flex Stack, Board Stacker, Through-Hole	317
ASP	Application Specific Product	14	ET60T	2.54 mm PowerStrip™ EXTreme Ten60Power™ Terminal	215			
AW	0.80 mm Flex Stack, Surface Mount Micro Board Stacker	279	ETMM	2 mm Shrouded Strain Relief IDC Header	336			
			ETMO	FireFly™ Extreme Environment Optical System	139	IBT1	URSA [®] I/O Ultra Rugged Cable Socket Housing	227
B1SD(T)	URSA [®] I/O Ultra Rugged Socket Cable Assembly	227	ETUO	FireFly™ Extended Temp Optical Micro Flyover System™	138	IDMX	2.54 mm Slim IDC Ribbon Cable, Terminal	330
B1SDS	URSA [®] I/O Metal Shell for Cable Socket Housing	227	EW	2.54 mm Flex Stack, Flexible .025" SQ Board Stacker	318	IDP1	1 mm Micro Mate™ Double Row Panel Mount Housing	253
B1SM	URSA[®] I/O Jack Cable with SMPM Contacts	230				IDSX	2.54 mm Slim IDC Ribbon Cable, Socket	330
BCS	2.54 mm Tiger Claw™ Pass-through, Through-Hole Socket	325	FC1	1 mm Flat Flexible Cable (FFC) Socket	342	IDT1	1 mm Micro Mate™ Double Row Terminal Housing	253
BCU	AcciiMate™ IP67 Sealed USB-C Cable Plug	234	FCDP	0.50 mm High-Speed Edge Card Socket for FEDP	134	IMPC	mPOWER™ Wire to Board Socket Housing	209
BPCU	AcciiMate™ IP67 Sealed USB-C Cable Receptacle	234	FEDP	0.50 mm High-Speed Edge Card Cable Assembly	134	IMPE	mPOWER™ Wire to Board Terminal Housing	210
BRU	AcciiMate™ IP67 Sealed USB-C Board Mount Receptacle	234	FCF8	0.80 mm High-Speed Cost-Effective Coax Cable Assembly	134	IMSS	PowerStrip™ /30 Amp Wire to Board Socket Housing	262
BSE	0.80 mm Basic Blade & Beam Socket	277	FCS8	0.80 mm High-Speed Cost-Effective Coax Cable Socket	134	IMSC5	PowerStrip™ /30 Amp Wire to Board Combo Housing	263
BSH	0.50 mm Basic Blade & Beam Socket	275	FMD	1.27 mm Tiger Eye™ IDC Ribbon Cable Assembly, Male	339	IPBD	4.19 mm Power Mate™ Wire to Board Socket Housing	259
BSS	0.635 mm Basic Blade & Beam Socket	276	FSD	1.27 mm Tiger Eye™ IDC Ribbon Cable Assembly, Female	338	IPBS	4.19 mm Power Mate™ Isolated Power Socket	224
BSW	2.54 mm Bottom Mount Socket Strip	326	FFTP	1.27 mm Tiger Eye™ IDC Twisted Pair Cable, Female	341	IPBT	4.19 mm Power Mate™ Isolated Power Terminal	224
BTE	0.80 mm Basic Blade & Beam Header	277	FJ	1 mm Flat Flexible Cable (FFC) Jumper	342	IPD1	2.54 mm Mini Mate™ Wire to Board Socket Housing	260
BTH	0.50 mm Basic Blade & Beam Header	274	FJH	0.50 mm Flat Flexible Cable (FFC) Jumper	342	IPL1	2.54 mm Mini Mate™ Shrouded Power Cable Terminal	261
BTS	0.635 mm Basic Blade & Beam Header	276	FLE	1.27 mm Tiger Beam™ Cost-Effective Reliable Socket	289	IPP1	URSA [®] I/O Ultra Rugged Cable Terminal Housing	228
			FMP5	5 mm PowerStrip™ /30 Amp "Hinging" Power Socket	216	IPS1	2.54 mm Mini Mate™ Isolated Power Connector Socket	223
CC03	Tiger Eye™ Contact for ISDF	254	FMP7	5 mm PowerStrip™ /30 Amp "Hinging" Power Header	216	IP66	PowerStrip™ /40 Amp Wire to Board Socket Housing	264
CC09	Micro Mate™ Contact for ISS1/ISD1	250	FMP8	1.27 mm Tiger Eye™ IDC Twisted Pair Cable, Male	341	IPT1	2.54 mm Mini Mate™ Isolated Power Connector Terminal	223
CC10	PowerStrip™ Contact for IPS6	264	FOLC	1.27 mm FOURRAY™ High-Density Tiger Eye™ Socket	240	ISD1	1 mm Micro Mate™ Double Row Socket Housing	251
CC396	Tiger Eye™ Contact for ISDE	257	FOPC	Fiber Optic Patch Cable	143	ISD2	2 mm Tiger Eye™ Wire to Board Socket Housing	256
CC46	PowerStrip™ Contact for IMSS and IMSC5	262	FOSFP-1	Flyover™ OSFP Cable System, 112 Gbps PAM4	100	ISDE	0.80 mm Tiger Eye™ Wire to Board Socket Housing	257
CC489	mPOWER™ Crimp Contact	209	FOSFP-2	Flyover™ OSFP Cable System, 224 Gbps PAM4	100	ISDF	1.27 mm Tiger Eye™ Wire to Board Socket Housing	254
CC508	URSA [®] I/O Crimp Contact	227	FOSFP	Flyover™ OSFP Cable System	103	ISP1	1 mm Micro Mate™ Single Row Panel Mount Housing	252
CC69	Power Mate™ Contact for IPBD	259	FQSFDP-D8	Flyover™ OSFP 800G Double Density Cable System	102	ISS1	1 mm Micro Mate™ Single Row Socket Housing	250
CC79	Mini Mate™ Contact for IPD1	260	FQSFDP-DD	Flyover™ OSFP Double Density Cable System	102	IST1	1 mm Micro Mate™ Single Row Terminal Housing	252
CC81	Tiger Eye™ Contact for ISD2 and IMSC5	256	FSS	0.50 mm High-Speed Floating Contact Socket	273			
CES	2.54 mm Closed Entry Low Profile Socket Strip	327	FSFP	Flyover™ SFP Cable System	99	JL	2.54 mm Jumper Link	328
CLE	0.80 mm Tiger Beam™ Cost-Effective Micro Socket	278	FSI	1 mm One-Piece Interface	270	JSO	Jack Screw Precision Board Stacking Standoff	35
CLM	1 mm Tiger Claw™ Rugged Reliable Micro Socket	282	FST	0.50 mm High-Speed Floating Contact Terminal	273	JSOM	Micro Jack Screw Precision Board Stacking Standoff	36
CLP	1.27 mm Low Profile Dual Wipe Socket	288	FTE	0.80 mm SMT Micro Header	278			
CLT	2 mm Low Profile Dual Wipe Socket	307	FTM	1 mm SMT Micro Low Profile Terminal Strip	280	LPAF	1.27 mm LP Array™ High-Speed Open-Pin-Field Array	31
CPC	Si-Fly™ LP Low Profile High-Density Copper Cable	121	FTMH	1 mm SMT Micro Terminal Strip	280	LPAM	1.27 mm LP Array™ High-Speed Open-Pin-Field Array	31
CPI	Si-Fly™ LP Low Profile High-Density Interconnect	121	FR	1.27 mm SMT Micro Terminal Strip	293	LPHS	PowerStrip™ EXTreme LPHPower™ Socket	213
CSSO	FireHawk™ Optical Transceiver for Space	145	FTS	1.27 mm Micro Low Profile Terminal Strip	286	LPHT	PowerStrip™ EXTreme LPHPower™ Terminal	213
			FTSH-SM	1.27 mm SMT Micro Terminal Strip	284	LP-FQSP	Light Pipe for QSFP and HS-QSFP	103
DW	2.54 mm Flex Stack, Flexible Board Stacker, .110" Tail	318	FTSH-TH	1.27 mm Through-Hole Micro Terminal Strip	285	LS2	2 mm Self-Mating Hermaphroditic Strip	308
DWM	1.27 mm Flex Stack, Flexible Micro Board Stacker	292	FW-SM	1.27 mm Flex Stack, SMT Micro Board Stacker	287	LSM	0.80 mm Razor Beam™ Hermaphroditic Strip	58
EBCB	ExaMAX™ Panel Retention Bracket	91	FW-TH	1.27 mm Flex Stack, Through-Hole Micro Board Stacker	287	LSHM-DH	0.50 mm Razor Beam™ Right-Angle Hermaphroditic Strip	57
EBC6	2 mm ExaMAX™ I/O Shielded Panel Mount Cable	109				LSHM-DV	0.50 mm Razor Beam™ Hermaphroditic Strip	57
EBCF	2 mm ExaMAX™ Backplane Cable Socket	90	GC6	0.60 mm Generate [®] Edge Card Cable Assembly	125	LSHM-RH	0.50 mm Razor Beam™ Reversed -RA Hermaphroditic Strip	57
EBCI	ExaMAX™ Vertical Latching Shroud	91	GC6RF	Generate [®] High-Speed Test Cable	126	LSS	0.635 mm Razor Beam™ Hermaphroditic Strip	58
EBCM	2 mm ExaMAX™ Backplane Cable Header	89	GMI	SUPERNOVA™ One-Piece Compression Interposer	32	LTH	0.50 mm Low Profile Blade & Beam Terminal	272
EBDM-RA	2 mm ExaMAX™ Direct Mate Orthogonal Header	88	GP50	SureWare™ Ultra Rugged Guide Post Standoffs	34	LTMM	2 mm Shrouded Terminal Strip	300
EBTC	ExaMAX™ I/O Shielded Right-Angle Cage for EBDM-RA	109	GPSOM	SureWare™ Ultra Rugged Micro Guide Post Standoffs	34			
EBTF-RA	2 mm ExaMAX™ Backplane Socket, Right-Angle	88				MCP	AcciiMate™ IP67 Mini Push-Pull Cable Assembly	233
EBTM	2 mm ExaMAX™ Backplane Header	87	HALO-C	Halo™ Next Gen Mid-Board Optical Transceiver	145	MCR	AcciiMate™ IP67 Mini Push-Pull Panel Assembly	233
EC2	2 mm Shrouded IDC Ejector Header Cap	336	HALO-PE	Halo Cu™ Copper Mid-Board Cable System	144	MEC1-DV	1 mm Mini Edge Card Socket, Vertical	75
ECDP	0.80 mm Twinax Edge Card Cable Assembly	134	HCMX	2.54 mm IDC Assembly, Terminal	330	MEC1-EM	1 mm Mini Edge Card Socket, Edge Mount	76
ECUE	FireFly™ Copper Micro Flyover System™	136	HCSX	2.54 mm IDC Assembly, Socket	330	MEC1-RA	1 mm Mini Edge Card Socket, Right-Angle	76
ECUO	FireFly™ Optical Micro Flyover System™	137	HDWM	1.27 mm Flex Stack, High Temp Micro Board Stacker	292	MEC2-DV	2 mm Mini Edge Card Socket, Vertical Surface Mount	77
EGBF	ExaMAX™ Socket Guide Module	91	HDTF	1.80 mm XCode™ HD Right-Angle Backplane Receptacle	94	MEC2-TH	2 mm Mini Edge Card Socket, Vertical Through-Hole	77
EGBM	ExaMAX™ Terminal Guide Module	91	HLCD	1.80 mm XCode™ HD Vertical Backplane Header	93	MEC5-DV	0.50 mm Micro Edge Card Socket, Vertical	71
EHF	1.27 mm Shrouded IDC Ejector Header	340	HLE	0.50 mm Razor Beam™ High-Speed Cable Assembly	134	MEC5-RA	0.50 mm Micro Edge Card Socket, Right-Angle	71
EHT	2 mm Shrouded IDC Ejector Header	336	HLF6	Halo™ Rugged High-Density Socket	144	MEC6-DV	0.635 mm Micro Edge Card Socket, Vertical	72
EIJH	2.54 mm Shrouded IDC Ejector Header	332	HMTSW	2.54 mm Flex Stack, High Temp Modified SQ Post Header	314	MEC6-RA	0.635 mm Micro Edge Card Socket, Right-Angle	72
EPTS	ExaMAX™ Socket Power Module	91	HPTS	XCode™ HD Power Module Socket	94	MEC8-DV	0.80 mm Micro Edge Card Socket, Vertical	73
EPTT	ExaMAX™ Terminal Power Module	91	HPTT	XCode™ HD Power Module Terminal	94	MEC8-RA	0.80 mm Micro Edge Card Socket, Right-Angle	74
EQCD	0.80 mm Q.Strip™ Coax Cable Assembly	134	HQCD	0.50 mm Q.Strip™ Coax Cable Assembly	134	MEC8-EM	0.80 mm Micro Edge Card Socket, Edge Mount	74
EQDP	0.80 mm Q.Pairs™ Twinax Cable Assembly	134	HQDP	0.50 mm Q.Pairs™ Twinax Cable Assembly	134	MEC8-VP	0.80 mm Micro Edge Card Socket, Press-Fit	73
EQRD	0.80 mm Q.Rate™ Coax Cable Assembly	134	HSC8	0.80 mm High-Speed Riser Card	65	MECF	1.27 mm Mini Edge Card Socket, Vertical	77
ERCD	0.80 mm Edge Rate™ Coax Cable Assembly	134	HSEC1-DV	1 mm Generate [®] Vertical Card Socket	69	MLE	1 mm Tiger Beam™ Cost-Effective Micro Socket	282
ERDP	0.80 mm Edge Rate™ Twinax Cable Assembly	134	HSEC6-DV	0.60 mm Generate [®] Vertical Card Socket	63	MMS	2 mm Tiger Claw™ Socket Strip	306
						MMSD(T)	2.54 mm Mini Mate™ Wire to Board Cable, Double Row	260

INDEX BY SERIES

Series	Description	Page	Series	Description	Page	Series	Description	Page
MMSS(T)	2.54 mm Mini Mate™ Wire to Board Cable, Single Row	260	OSH-RA	0.50 mm Q Strip™ High-Speed Socket, Right-Angle	46	SSA	0.40 mm Micro Blade & Beam Ultra-Fine Pitch Socket	59
MMT	2 mm Horizontal Surface Mount Terminal	297	OSS	0.635 mm Q Strip™ High-Speed Ground Plane Socket	41	SSS	0.50 mm Micro Blade & Beam Low Profile Socket	60
MNT	2.54 mm Multi-Position Shunt	328	OSS-RA	0.635 mm Q Strip™ Ground Plane Socket, Right-Angle	46	SSM	2.54 mm Tiger Claw™ Pass-Through SMT Socket	322
MOLC	1.27 mm FOURRAY™ High-Density High-Reliability Header	240	QTE	0.80 mm Q Strip™ High-Speed Ground Plane Header	40	SSQ	2.54 mm Tiger Buy™ Socket .025" SQ Post	320
MPCC	PowerStrip™/30 Amp Power/Signal Combo Assembly	263	QTH	0.50 mm Q Strip™ High-Speed Ground Plane Header	39	SSW	2.54 mm Tiger Buy™ Through-Hole Socket	320
MPPT	5 mm PowerStrip™/30 Amp Hermaphroditic Power System	216	QTH-RA	0.50 mm Q Strip™ High-Speed Header, Right-Angle	46	SSW-SM	2.54 mm Tiger Buy™ SMT Socket	321
MPS	5 mm PowerStrip™/30 Amp Dual Leaf Socket	218	QTS	0.635 mm Q Strip™ High-Speed Ground Plane Header	41	ST4	0.40 mm Micro Blade & Beam Ultra Fine Pitch Header	59
MPS-RA	5 mm PowerStrip™/30 Amp Right-Angle Power Socket	218	QTS-RA	0.635 mm Q Strip™ Ground Plane Header, Right-Angle	46	STS	0.50 mm Micro Blade & Beam Low Profile Header	60
MPSC	PowerStrip™/30 Amp Signal/Power Combo Socket	219	RPBE	AccliMate™ IP68 Sealed Ethernet Panel Mount Socket	234	STMM	2 mm Flex Stack, Shrouded Terminal Cable Strip	337
MPSC-RA	PowerStrip™/30 Amp Right-Angle Signal/Power Socket	219	RPBU	AccliMate™ IP68 Sealed USB Panel Mount Socket	234	T1M	1 mm Micro Mate™ Wire to Board Terminal	249
MPSS	5 mm PowerStrip™/30 Amp Power Cable	262	RPCE	AccliMate™ IP68 Sealed Ethernet Panel Mount Socket Cable	234	T2M	2 mm Tiger Eye™ High-Reliability Wire to Board Cable Header	245
MPT	5 mm PowerStrip™/30 Amp Dual Blade Terminal	218	RPCU	AccliMate™ IP68 Sealed USB Panel Mount Cable	234	TC145	URSA™ I/O Crimp Terminal	218
MPT-RA	5 mm PowerStrip™/30 Amp Right-Angle Power Terminal	218	RSM	1.27 mm Surface Mount Micro Socket	293	TC146	mPOWER™ Crimp Terminal	220
MPTC	PowerStrip™/30 Amp Signal/Power Combo Terminal	219	RUB	0.80 mm High-Speed Edge Card Riser Kit	65	TC37	Micro Mate™ Crimp Terminal	252
MPTC-RA	PowerStrip™/30 Amp Right-Angle Signal/Power Terminal	219	S1SD(T)	1 mm Micro Mate™ Socket Assembly, Double Row	251	TCMD	2 mm Tiger Eye™ IDC High-Reliability Header Cable	335
MTLW	2.54 mm Flex Stack, Low Profile .025" SQ Post Header	316	S1SS(T)	1 mm Micro Mate™ Socket Assembly, Single Row	250	TCSD	2 mm Tiger Eye™ IDC Socket Cable	334
MTMM	2 mm FlexXYZ™ Modified Through-Hole Header	297	S2M	2 mm Tiger Eye™ Wire to Board Cable Socket	245	TEM	0.80 mm Tiger Eye™ Micro Header	243
MTSW	2.54 mm Flex Stack, Modified SQ Post Header	314	S2SD(T)	2 mm Tiger Eye™ Wire to Board Socket Cable, Double Row	256	TEMS	0.80 mm Tiger Eye™ Micro Header, Slim	243
MWS	1 mm Flex Stack, Surface Mount Micro Board Header	281	S2SS(T)	2 mm Tiger Eye™ Wire to Board Socket Cable, Single Row	256	TFC	1.27 mm Tiger Eye™ Cost-Effective Reliable Header	239
NVA3E	NovaRay™ I/O 38999 Ultra Rugged Cable	107	SAL1	1 mm High-Speed Micro Plane Socket	67	TFM	1.27 mm Tiger Eye™ High-Reliability Header	238
NVA3P	NovaRay™ I/O 38999 Ultra Rugged Panel Mount Cable	107	SCRES	AccliMate™ IP68 Sealed Circular Ethernet Cable Socket	234	TFML	1.27 mm Tiger Eye™ High-Reliability Locking Header	238
NVAC	NovaRay™ Extreme Density & Performance Cable	113	SCRUS	AccliMate™ IP68 Sealed Circular USB 2.0 Panel Mount Socket	234	TLE	2 mm Tiger Beam™ Cost-Effective Reliable Socket	307
NVACE	NovaRay™ I/O Extreme Performance Cable	106	SEAC	1.27 mm SEARAY™ High-Speed/High-Density Jumper	131	TLH	0.50 mm Micro Blade & Beam Ultra Low Profile Header	60
NVACP	NovaRay™ I/O Panel Mount Cable Assembly	105	SEAF	1.27 mm SEARAY™ High-Density Open-Pin-Field, Socket	25	TLW	2.54 mm Flex Stack, Low Profile .025" SQ Post Header	316
NVAF	NovaRay™ Extreme Density & Performance Socket	17	SEAF-RA	1.27 mm SEARAY™ Right-Angle Open-Pin-Field, Socket	26	TML	1.27 mm Shrouded Micro Header	291
NVAM	NovaRay™ Extreme Density & Performance Terminal	17	SEAF8	0.80 mm SEARAY™ Ultra-High-Density Array, Socket	29	TMM-SM	2 mm Low Profile SMT Header	295
NVAM-CT	NovaRay™ Terminal for NVAC Series	113	SEAF8-RA	0.80 mm SEARAY™ Right-Angle Open-Pin-Field, Socket	29	TMM-TH	2 mm FlexXYZ™ Low Profile Through-Hole Header	296
NVBF	NovaRay™ Backplane Socket	83	SEAFP	1.27 mm SEARAY™ Press-Fit High-Density Array, Socket	27	TMMH-SM	2 mm Flexible SMT Header	298
NVBM-RA	NovaRay™ Backplane Right-Angle Terminal	83	SEAM	1.27 mm SEARAY™ High-Density Open-Pin-Field, Terminal	25	TMMH-TH	2 mm FlexXYZ™ Flexible Through-Hole Header	299
NVC	NovaRay™ I/O Die Cast Panel Cage for NVACP	105	SEAM-GP	1.27 mm SEARAY™ High-Density Guide Post Array, Terminal	26	TMMS	2 mm Shrouded Quad Row Header	301
NVCF	NovaRay™ Micro Rugged Backplane Cable, Socket	85	SEAM-RA	1.27 mm SEARAY™ Right-Angle Open-Pin-Field, Terminal	26	TMS	1.27 mm Through-Hole Micro Header	290
NVCM-RA	NovaRay™ Micro Rugged Backplane Cable, Terminal	84	SEAM8	0.80 mm SEARAY™ Ultra-High-Density Array, Terminal	29	TOLC	0.635 mm FOURRAY™ Quad Row SMT Terminal	283
OPA	Optical Patch Adaptor	143	SEAMI	1.27 mm SEARAY™ 85 Ω High-Density Array, Terminal	27	TSH	2 mm Shrouded Header	301
OSFPC	Cage for FOSFP-1 & FOSFP-2	101	SEAMP	1.27 mm SEARAY™ Press-Fit High-Density Array, Terminal	27	TSM	2.54 mm SMT .025" SQ Post Header	312
P1M	URSA™ I/O Ultra Rugged Board Mount Connector	229	SEAR	1.27 mm SEARAY™ High-Density Riser, 85 Ω	27	TSS	2.54 mm Flex Stack, Shrouded Header	319
P1PD(T)	URSA™ I/O Ultra Rugged Panel Mount Terminal Cable	228	SEI	1 mm Single Row One-Piece Interface	270	TST	2.54 mm Flex Stack, Shrouded Cable Header	333
P1PDS	URSA™ I/O Metal Shell for Cable Terminal Housing	228	SEM	0.80 mm Tiger Eye™ Micro Socket	243	TSW	2.54 mm Through-Hole .025" SQ Post Header	310
P15M	URSA™ I/O Plug Cable with SMPM Contacts	230	SEMS	0.80 mm Tiger Eye™ Slim Micro Socket	243	T1PD(T)	1 mm Micro Mate™ Panel Mount Terminal, Double Row	253
PCIE	1 mm PCI Express™ 3.0 Edge Card Socket	79	SESDT	0.80 mm Tiger Eye™ Wire to Board Socket Cable Assembly	257	T1PS(T)	1 mm Micro Mate™ Panel Mount Terminal, Single Row	252
PCIE-G4	1 mm PCI Express™ 4.0 Edge Card Socket	80	SFC	1.27 mm Tiger Eye™ Cost-Efficient Reliable Socket	239	T1SD(T)	1 mm Micro Mate™ Terminal Assembly, Double Row	253
PCIE-G5	1 mm PCI Express™ 5.0 Edge Card Socket	80	SFCC	Si-Fly™ HD Co-Packaged Cable Assembly	123	T1SS(T)	1 mm Micro Mate™ Terminal Assembly, Single Row	252
PCIE-LP	1 mm PCI Express™ Low Profile Edge Card Socket	79	SFCM	Si-Fly™ HD Co-Packaged Substrate Connector	123	TW-SM	2 mm Flex Stack, Flexible Board Stacker, SMT	302
PCIEC	1 mm PCI Express™ 3.0 Internal Cable Assembly	132	SFM	1.27 mm Tiger Eye™ High-Reliability Socket	237	TW-TH	2 mm FlexXYZ™ Flexible Board Stacker, Through-Hole	302
PCIEC-G4	1 mm PCI Express™ 4.0 Internal Cable Assembly	132	SFMC	1.27 mm Tiger Eye™ Flexible Pin Count Socket	241	2SN	2 mm Shunt	328
PCIEC-G5	1 mm PCI Express™ 5.0 Internal Cable Assembly	132	SFML	1.27 mm Tiger Eye™ High-Reliability Locking Socket	237	UCC8	FireFly™ Positive Latching Receptacle	141
PCOA	PCIe™-Over-Fiber FireFly™ Adaptor Card	142	SFNC	Si-Fly™ HD Near-Chip Cable Assembly	124	UDF6	AcceleRate™ mP Signal/Power Combo Socket	23
PCRFR-G4	PCI Express™ 4.0 High-Speed Test Cable	133	SFNM	Si-Fly™ HD Near-Chip Board Connector	124	UDM6	AcceleRate™ mP Signal/Power Combo Terminal	23
PCRFR-G5	PCI Express™ 5.0 High-Speed Test Cable	133	SFPC-F	Cage for FSFP	99	UECS	FireFly™ Edge Card Socket	141
PCUE	PCIe™-Over-FireFly™ Copper Flyover™ Cable	136	SFSD(T)	1.27 mm Tiger Eye™ Wire to Board Cable, Double Row	255	UMPC(T)	mPOWER™ Ultra Micro Power Cable	209
PCUO	PCIe™-Over-Fiber FireFly™ Optical Flyover™ Cable	140	SFSS(T)	1.27 mm Tiger Eye™ Wire to Board Cable, Single Row	254	UMPE(T)	mPOWER™ Cable-to-Cable Assembly, Terminal	210
PES	6.35 mm PowerStrip™/40 Amp High Power Socket	220	SHF	1.27 mm Shrouded IDC Header	340	UMPI(T)	mPOWER™ Cable-to-Cable Panel Mount Assembly, Socket	211
PESC	PowerStrip™/40 Amp Signal/Power Socket	221	SIB	2.54 mm One-Piece Interfaces	271	UMPS	2 mm mPOWER™ Ultra Micro Power Socket	207
PESS	6.35 mm PowerStrip™/40 Amp Cable Assembly	264	SIBF	1.27 mm One-Piece Interfaces	270	UMPT	2 mm mPOWER™ Ultra Micro Power Terminal	208
PET	6.35 mm PowerStrip™/40 Amp High Power Terminal	220	SIR1	2.54 mm One-Piece Right-Angle Interfaces	271	UPPT	PowerStrip™/20 Amp Hermaphroditic Power System	217
PETC	PowerStrip™/40 Amp Signal/Power Terminal	221	SLH	0.50 mm Micro Blade & Beam Ultra Low Profile Socket	60	UPS	3.81 mm PowerStrip™/20 Amp Dual Leaf Power Socket	217
PHF	2.54 mm Press-Fit Socket	309	SLM	1.27 mm Tiger Buy™ Low Profile Micro Socket	294	UPT	3.81 mm PowerStrip™/20 Amp Dual Blade Power Terminal	217
PHT	2.54 mm Press-Fit Terminal	309	SLW	2.54 mm Tiger Buy™ Low Profile Socket Strip	327	ZF1	1 mm Flat Flexible Cable (FFC) Socket	342
PMSD(T)	4.19 mm Power Mate™ Wire to Board Cable, Double Row	259	SMM	2 mm Tiger Eye™ High-Reliability Socket	246	ZF5S	0.50 mm Flat Flexible Cable (FFC) Socket	342
PMSS(T)	4.19 mm Power Mate™ Wire to Board Cable, Single Row	259	SMS	1.27 mm Through-Hole Micro Socket	294	ZLTMM	2 mm Flex Stack, Shrouded Elevated Terminal Strip	300
PTF	2 mm Press-Fit Socket	303	SNM	2.54 mm Micro Shunt	328	ZML	1.27 mm Flex Stack, Shrouded Elevated Stacker	291
PTHF	2 mm PC/104-Plus™ Self-Nesting Socket	304	SNT	2.54 mm Shunt	328	ZSS	2.54 mm Flex Stack, Elevated Shrouded Header	319
PIT	2 mm Press-Fit Terminal	303	SO	Precision Board Stacking Standoff	36	ZST	2.54 mm Flex Stack, Elevated Shrouded Cable Header	333
PTUO	PCIe™-Over-Fiber FireFly™ Extended Temp Optical Cable	140	SOLC	0.635 mm FOURRAY™ Quad Row SMT Socket	283	ZSTMM	2 mm Flex Stack, Shrouded Elevated Cable Header	337
QFS	0.635 mm Q2™ Rugged Ground Plane Socket	42	SQT	2 mm FlexXYZ™ Cost-Effective Rugged Socket, Square Tail	305	ZW	2.54 mm Flex Stack, Flexible .025" SQ Board Stacker	318
QFS-EM	0.635 mm Q2™ Ground Plane Socket, Edge Mount	47	SQW	2 mm FlexXYZ™ Cost-Effective Rugged Socket, Solder Tail	305			
QFS-RA	0.635 mm Q2™ Ground Plane Socket, Right-Angle	47						
QFSS	0.635 mm Q2™ Shielded Ground Plane Socket	43						
QMS	0.635 mm Q2™ Rugged Ground Plane Header	42						
QMS-EM	0.635 mm Q2™ Ground Plane Header, Edge Mount	47						
QMS-RA	0.635 mm Q2™ Ground Plane Header, Right-Angle	47						
QMSS	0.635 mm Q2™ Shielded Ground Plane Header	43						
QRF8	0.80 mm Q Rate™ Slim Body Ground Plane Socket	44						
QRF8-RA	0.80 mm Q Rate™ Slim Body Socket, Right-Angle	47						
QRMB	0.80 mm Q Rate™ Slim Body Ground Plane Header	44						
QRMB-RA	0.80 mm Q Rate™ Slim Body Header, Right-Angle	47						
QSE	0.80 mm Q Strip™ High-Speed Ground Plane Socket	40						
QSFP	Cage for QSFP	103						
QSFP-D8	Cage for QSFP-D8	102						
QSH	0.50 mm Q Strip™ High-Speed Ground Plane Socket	39						

RF PRODUCTS

See page 351 for available RF Solutions.

GENERAL POLICY INFORMATION

Unless otherwise agreed by Samtec in writing, all sales of Samtec products are subject to Samtec's Terms and Conditions of Sale located at <https://www.samtec.com/about/legal/#samtecterms>

Federal Supply Code: 55322

Notes:

New products highlighted in bold.

Most older products not shown in the catalog are still available. Visit www.samtec.com and the homepage search bar for availability and specifications.

High-Speed
Board-to-Board

High-Speed
Cables

Optics

RF

Rugged/Power

Flexible Stacking



Scan the Code to Find Your
Samtec Location or Visit:
samtec.com/locations

samtec
SUDDEN SERVICE®

www.samtec.com

ISO-9001 and/or IATF 16949 Certified

© DECEMBER 2025, SAMTEC INC.

